

LZP-Series

Highest Lumen Density
Warm White Emitter

LZP-00WW0R

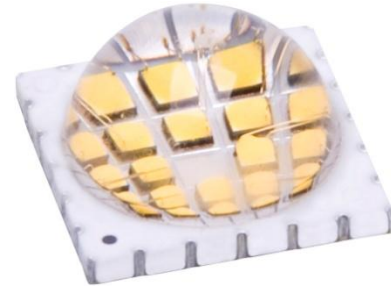

Key Features

- Highest luminous flux / area single LED emitter
 - 4650lm Warm White
 - 40mm² light emitting area
- Up to 90 Watt power dissipation on compact 12.0mm x 12.0mm footprint
- Industry lowest thermal resistance per package size (0.6°C/W)
- Industry leading lumen maintenance
- Color Point Stability 7x improvement over Energy Star requirements
- High CRI performance for true color rendering
- Surface mount ceramic package with integrated glass lens
- JEDEC Level 1 for Moisture Sensitivity Level
- Lead (Pb) free and RoHS compliant
- Reflow solderable (up to 6 cycles)
- Copper core MCPCB option with emitter thermal slug directly soldered to the copper core
- Full suite of TIR secondary optics family available

Typical Applications

- General lighting
- Shop lighting
- Stage and Studio lighting
- Architectural lighting

Description

The LZP-00WW0R Warm White LED emitter can dissipate up to 90W of power in an extremely small package. With a small 12.0mm x 12.0mm footprint, this package provides unmatched luminous flux density. The high quality materials used in the package are chosen to optimize light output and minimize stresses which results in superior reliability and lumen maintenance. The robust product design thrives in outdoor applications with high ambient temperatures and high humidity.

Part number options

Base part number

Part number	Description
LZP-00WW0R-xxxx	LZP Warm White emitter
LZP-D0WW0R-xxxx	LZP Warm White emitter on 5 channel 4x6+1 Star MCPCB

Bin kit option codes

WW, Warm-White (2700K – 3500K)			
Kit number suffix	Min flux Bin	Color Bin Ranges	Description
0027	F2	8A1, 8A2, 8B1, 8B2, 8A4, 8A3, 8B4, 8B3, 8D1, 8D2, 8C1, 8C2, 8D4, 8D3, 8C4, 8C3	full distribution flux; 2700K ANSI CCT bin
0227	F2	8A2, 8B1, 8A3, 8B4, 8D2, 8C1, 8D3, 8C4	full distribution flux; 2700K ANSI CCT half bin
0427	F2	8A3, 8B4, 8D2, 8C1	full distribution flux; 2700K ANSI CCT quarter bin
0030	F2	7A1, 7A2, 7B1, 7B2, 7A4, 7A3, 7B4, 7B3, 7D1, 7D2, 7C1, 7C2, 7D4, 7D3, 7C4, 7C3	full distribution flux; 3000K ANSI CCT bin
0230	F2	7A2, 7B1, 7A3, 7B4, 7D2, 7C1, 7D3, 7C4	full distribution flux; 3000K ANSI CCT half bin
0430	F2	7A3, 7B4, 7D2, 7C1	full distribution flux; 3000K ANSI CCT quarter bin
0035	F2	6A1, 6A2, 6B1, 6B2, 6A4, 6A3, 6B4, 6B3, 6D1, 6D2, 6C1, 6C2, 6D4, 6D3, 6C4, 6C3	full distribution flux; 3500K ANSI CCT bin
0235	F2	6A2, 6B1, 6A3, 6B4, 6D2, 6C1, 6D3, 6C4	full distribution flux; 3500K ANSI CCT half bin
0435	F2	6A3, 6B4, 6D2, 6C1	full distribution flux; 3500K ANSI CCT quarter bin

Warm White Chromaticity Groups

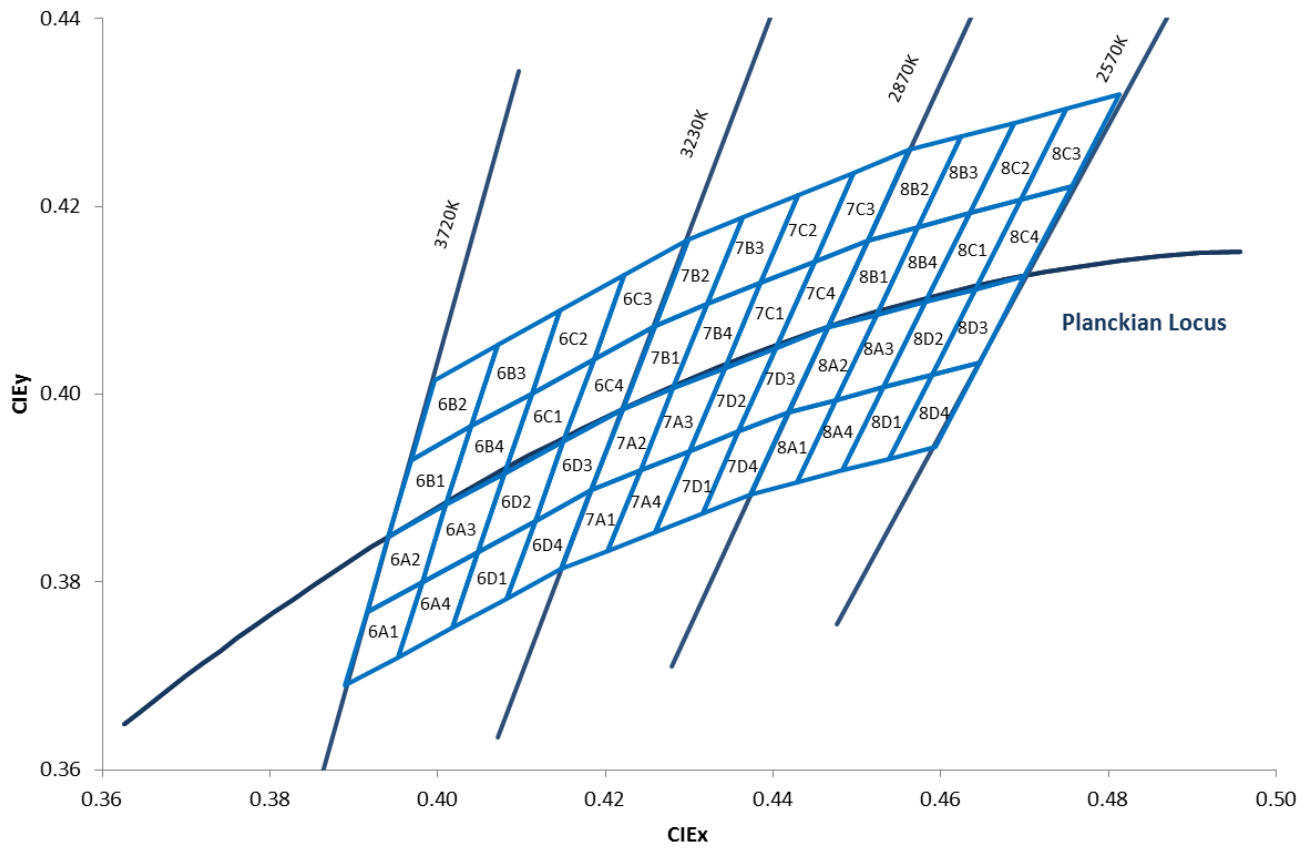

Standard Chromaticity Groups plotted on excerpt from the CIE 1931 (2°) x-y Chromaticity Diagram. Coordinates are listed below in the table.

Warm White Bin Coordinates

Bin code	CIEx	CIEy	Bin code	CIEx	CIEy	Bin code	CIEx	CIEy	Bin code	CIEx	CIEy
6A1	0.3889	0.369	6A2	0.3915	0.3768	6B1	0.3941	0.3848	6B2	0.3968	0.393
	0.3915	0.3768		0.3941	0.3848		0.3968	0.393			
	0.3981	0.38		0.401	0.3882		0.404	0.3966			
	0.3953	0.372		0.3981	0.38		0.401	0.3882			
6A4	0.3889	0.369	6A3	0.3915	0.3768	6B4	0.3941	0.3848	6B3	0.3968	0.393
	0.3953	0.372		0.3981	0.38		0.401	0.3882		0.404	0.3966
	0.3981	0.38		0.401	0.3882		0.404	0.3966		0.404	0.3966
	0.4048	0.3832		0.408	0.3916		0.4113	0.4001		0.4146	0.4089
6D1	0.4017	0.3751	6D2	0.4048	0.3832	6C1	0.408	0.3916	6C2	0.4113	0.4001
	0.4048	0.3832		0.408	0.3916		0.4113	0.4001		0.4146	0.4089
	0.4116	0.3865		0.415	0.395		0.4186	0.4037		0.4222	0.4127
	0.4082	0.3782		0.4116	0.3865		0.415	0.395		0.4186	0.4037
6D4	0.4017	0.3751	6D3	0.4048	0.3832	6C4	0.408	0.3916	6C3	0.4113	0.4001
	0.4082	0.3782		0.4116	0.3865		0.415	0.395		0.4186	0.4037
	0.4116	0.3865		0.415	0.395		0.4186	0.4037		0.4222	0.4127
	0.4183	0.3898		0.4221	0.3984		0.4259	0.4073		0.4299	0.4165
7A1	0.4147	0.3814	7A2	0.4183	0.3898	7B1	0.4221	0.3984	7B2	0.4259	0.4073
	0.4183	0.3898		0.4221	0.3984		0.4259	0.4073		0.4299	0.4165
	0.4242	0.3919		0.4281	0.4006		0.4322	0.4096		0.4364	0.4188
	0.4203	0.3833		0.4242	0.3919		0.4281	0.4006		0.4322	0.4096
7A4	0.4147	0.3814	7A3	0.4183	0.3898	7B4	0.4221	0.3984	7B3	0.4259	0.4073
	0.4242	0.3919		0.4281	0.4006		0.4322	0.4096		0.4364	0.4188
	0.4203	0.3833		0.4242	0.3919		0.4281	0.4006		0.4322	0.4096
	0.4259	0.3853		0.43	0.3939		0.4342	0.4028		0.4385	0.4119
7D1	0.4259	0.3853	7D2	0.4342	0.4028	7C1	0.4385	0.4119	7C2	0.443	0.4212
	0.43	0.3939		0.4342	0.4028		0.4385	0.4119		0.443	0.4212
	0.4359	0.396		0.4403	0.4049		0.4449	0.4141		0.4496	0.4236
	0.4316	0.3873		0.4359	0.396		0.4403	0.4049		0.4449	0.4141
7D4	0.4259	0.3853	7D3	0.43	0.3939	7C4	0.4342	0.4028	7C3	0.4385	0.4119
	0.43	0.3939		0.4342	0.4028		0.4385	0.4119		0.443	0.4212
	0.4359	0.396		0.4403	0.4049		0.4449	0.4141		0.4496	0.4236
	0.4316	0.3873		0.4359	0.396		0.4403	0.4049		0.4449	0.4141
8A1	0.4316	0.3873	8A2	0.4359	0.396	8B1	0.4403	0.4049	8B2	0.4449	0.4141
	0.4359	0.396		0.4403	0.4049		0.4449	0.4141		0.4496	0.4236
	0.4418	0.3981		0.4465	0.4071		0.4513	0.4164		0.4562	0.426
	0.4373	0.3893		0.4418	0.3981		0.4465	0.4071		0.4513	0.4164
8A4	0.4316	0.3873	8A3	0.4359	0.396	8B4	0.4403	0.4049	8B3	0.4449	0.4141
	0.4373	0.3893		0.4418	0.3981		0.4465	0.4071		0.4513	0.4164
	0.4418	0.3981		0.4465	0.4071		0.4513	0.4164		0.4562	0.426
	0.4475	0.3994		0.4523	0.4085		0.4573	0.4178		0.4624	0.4274
8D1	0.4428	0.3906	8D2	0.4475	0.3994	8C1	0.4465	0.4071	8C2	0.4513	0.4164
	0.4475	0.3994		0.4475	0.3994		0.4465	0.4071		0.4513	0.4164
	0.4532	0.4008		0.4523	0.4085		0.4523	0.4085		0.4573	0.4178
	0.4483	0.3919		0.4582	0.4099		0.4573	0.4178		0.4624	0.4274
8D4	0.4428	0.3906	8D3	0.4475	0.3994	8C4	0.4465	0.4071	8C3	0.4513	0.4164
	0.4475	0.3994		0.4475	0.3994		0.4465	0.4071		0.4513	0.4164
	0.4532	0.4008		0.4523	0.4085		0.4523	0.4085		0.4573	0.4178
	0.4483	0.3919		0.4582	0.4099		0.4573	0.4178		0.4624	0.4274
8D1	0.4483	0.3919	8D2	0.4532	0.4008	8C1	0.4582	0.4099	8C2	0.4634	0.4193
	0.4532	0.4008		0.4532	0.4008		0.4582	0.4099		0.4634	0.4193
	0.4589	0.4021		0.4641	0.4112		0.4695	0.4207		0.475	0.4304
	0.4538	0.3931		0.4589	0.4021		0.4641	0.4112		0.4695	0.4207
8D4	0.4483	0.3919	8D3	0.4532	0.4008	8C4	0.4582	0.4099	8C3	0.4634	0.4193
	0.4532	0.4008		0.4582	0.4099		0.4634	0.4193		0.4687	0.4289
	0.4589	0.4021		0.4641	0.4112		0.4695	0.4207		0.475	0.4304
	0.4538	0.3931		0.4589	0.4021		0.4641	0.4112		0.4695	0.4207
8D4	0.4538	0.3931	8D3	0.4641	0.4112	8C4	0.4695	0.4207	8C3	0.475	0.4304
	0.4589	0.4021		0.4641	0.4112		0.4695	0.4207		0.475	0.4304
	0.4646	0.4034		0.47	0.4126		0.4756	0.4221		0.4813	0.4319
	0.4593	0.3944		0.4646	0.4034		0.47	0.4126		0.4756	0.4221
	0.4538	0.3931		0.4589	0.4021		0.4641	0.4112		0.4695	0.4207

Luminous Flux Bins

Table 1:

Bin Code	Minimum Luminous Flux (Φ_v) @ $I_F = 700\text{mA}$ /Channel^[1,2] (lm)	Maximum Luminous Flux (Φ_v) @ $I_F = 700\text{mA}$ /Channel^[1,2] (lm)
F2	2,900	3,200
G2	3,200	3,500
H2	3,500	3,800

Notes:

1. Luminous flux performance guaranteed within published operating conditions. LED Engin maintains a tolerance of $\pm 10\%$ on flux measurements.
2. Luminous Flux typical value is for all 24 LED dies operating at rated current. The LED is configured with 4 Channels of 6 dies in series.

Forward Voltage Bin

Table 2:

Bin Code	Minimum Forward Voltage (V_f) @ $I_F = 700\text{mA}$ /Channel^[1] (V)	Maximum Forward Voltage (V_f) @ $I_F = 700\text{mA}$ /Channel^[1] (V)
0	18.0 ^[2,3]	21.6 ^[2,3]

Notes:

1. LED Engin maintains a tolerance of $\pm 0.24\text{V}$ for forward voltage measurements.
2. All 4 white Channels have matched V_f for parallel operation
3. Forward Voltage is binned with 6 LED dies connected in series. The LED is configured with 4 Channels of 6 dies in series each.

Absolute Maximum Ratings

Table 3:

Parameter	Symbol	Value	Unit
DC Forward Current at $T_{jmax}=135^{\circ}\text{C}^{[1]}$	I_F	1200	mA
DC Forward Current at $T_{jmax}=150^{\circ}\text{C}^{[1]}$	I_F	1000	mA
Peak Pulsed Forward Current ^[2]	I_{FP}	1500 /Channel	mA
Reverse Voltage	V_R	See Note 3	V
Storage Temperature	T_{stg}	-40 ~ +150	$^{\circ}\text{C}$
Junction Temperature	T_J	150	$^{\circ}\text{C}$
Soldering Temperature ^[4]	T_{sol}	260	$^{\circ}\text{C}$
Allowable Reflow Cycles		6	
ESD Sensitivity ^[5]		> 8,000 V HBM Class 3B JESD22-A114-D	

Notes:

- Maximum DC forward current (per die) is determined by the overall thermal resistance and ambient temperature. Follow the curves in Figure 12 for current de-rating.
- Pulse forward current conditions: Pulse Width $\leq 10\text{msec}$ and Duty cycle $\leq 10\%$.
- LEDs are not designed to be reverse biased.
- Solder conditions per JEDEC 020D. See Reflow Soldering Profile Figure 5.
- LED Engin recommends taking reasonable precautions towards possible ESD damages and handling the LZP-00WW0R in an electrostatic protected area (EPA). An EPA may be adequately protected by ESD controls as outlined in ANSI/ESD S6.1.

Optical Characteristics @ $T_C = 25^{\circ}\text{C}$

Table 4:

Parameter	Symbol	Typical	Unit
Luminous Flux (@ $I_F = 700\text{mA}^{[1]}$)	Φ_V	3600	lm
Luminous Flux (@ $I_F = 1000\text{mA}^{[1]}$)	Φ_V	4650	lm
Luminous Efficacy (@ $I_F = 350\text{mA}$)		86	lm/W
Correlated Color Temperature	CCT	3000	K
Color Rendering Index (CRI)	R_a / R_9	83 / 15	
Viewing Angle ^[2]	$2\Theta_{1/2}$	110	Degrees

Notes:

- Luminous flux typical value is for all 24 LED dies operating at rated current.
- Viewing Angle is the off-axis angle from emitter centerline where the luminous intensity is $\frac{1}{2}$ of the peak value.

Electrical Characteristics @ $T_C = 25^{\circ}\text{C}$

Table 5:

Parameter	Symbol	Typical	Unit
Forward Voltage (@ $I_F = 700\text{mA}^{[1]}$)	V_F	18.9 /Channel	V
Forward Voltage (@ $I_F = 1000\text{mA}^{[1]}$)	V_F	19.5 /Channel	V
Temperature Coefficient of Forward Voltage ^[1]	$\Delta V_F / \Delta T_J$	-16.8	mV/ $^{\circ}\text{C}$
Thermal Resistance (Junction to Case)	$R\Theta_{J-C}$	0.6	$^{\circ}\text{C}/\text{W}$

Notes:

- Forward Voltage is measured for a single string of 6 dies connected in series. The LED is configured with 4 Channels of 6 dies in series each.

IPC/JEDEC Moisture Sensitivity Level

Table 6 - IPC/JEDEC J-STD-20D.1 MSL Classification:

Level	Soak Requirements					
	Floor Life		Standard		Accelerated	
	Time	Conditions	Time (hrs)	Conditions	Time (hrs)	Conditions
1	unlimited	≤ 30°C/ 85% RH	168 +5/-0	85°C/ 85% RH	n/a	n/a

Notes:

- The standard soak time includes a default value of 24 hours for semiconductor manufacturer's exposure time (MET) between bake and bag and includes the maximum time allowed out of the bag at the distributor's facility.

Average Lumen Maintenance Projections

Lumen maintenance generally describes the ability of a lamp to retain its output over time. The useful lifetime for solid state lighting devices (Power LEDs) is also defined as Lumen Maintenance, with the percentage of the original light output remaining at a defined time period. L70 defines the amount of operating hours at which the light output has reached 70% of its original output.

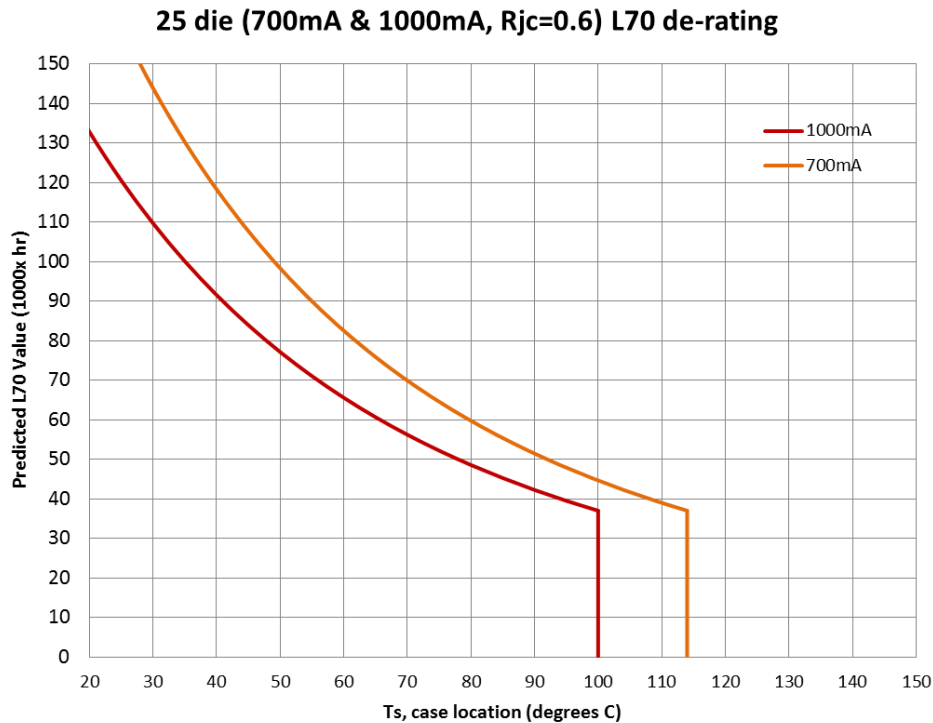

Figure 1: De-rating curve for operation of all dies at 700mA

Notes:

- Ts is a thermal reference point on the case of the emitter.

Mechanical Dimensions (mm)

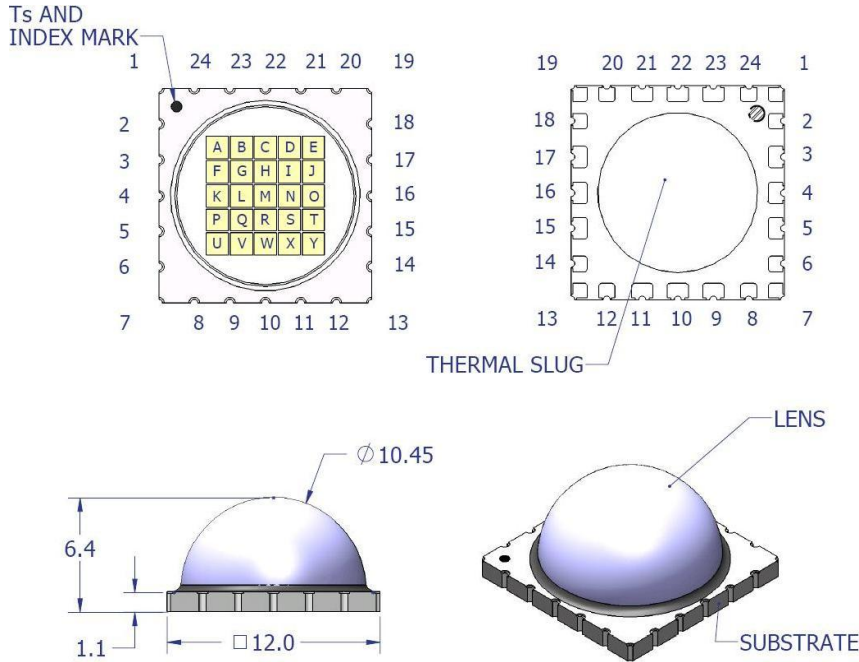

Figure 2: Package outline drawing.

Notes:

1. LZP-00xW0R pin out polarity is reversed; therefore it is not compatible with MCPCB designed for LZP-00xW00 products, except for LZP-00SW00 and LZP-00GW00.
2. Index mark, Ts indicates case temperature measurement point.
3. Unless otherwise noted, the tolerance = ± 0.20 mm.
4. Thermal slug is electrically isolated

Pin Out				
Ch.	Pad	Die	Color	Function
1	18	E	WW	Cathode
		D	WW	na
		C	WW	na
		B	WW	na
		A	WW	na
2	24	F	WW	Anode
	17	J	WW	Cathode
		I	WW	na
		H	WW	na
		G	WW	na
3		L	WW	na
	3	K	WW	Anode
	15	O	WW	Cathode
		N	WW	na
		S	WW	na
4		R	WW	na
		Q	WW	na
	5	P	WW	Anode
	14	T	WW	Cathode
		Y	WW	na
5		X	WW	na
		W	WW	na
		V	WW	na
	8	U	WW	Anode
5	2	M	-	na
	23	M	-	na

Recommended Solder Pad Layout (mm)

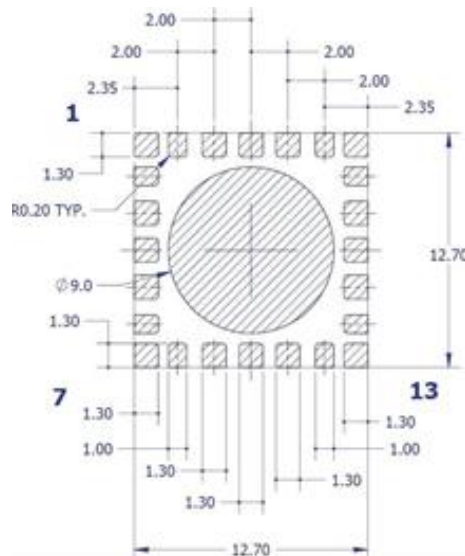
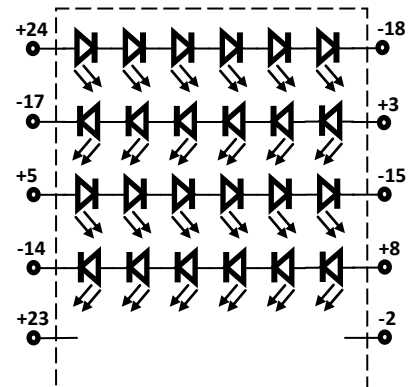

Figure 3: Recommended solder mask opening (hatched area) for anode, cathode, and thermal pad.

Notes:

1. Unless otherwise noted, the tolerance = ± 0.20 mm.
2. LED Engin recommends the use of copper core MCPCB's which allow for the emitter thermal slug to be soldered directly to the copper core (so called pedestal design). Such MCPCB technologies eliminate the high thermal resistance dielectric layer that standard MCPCB technologies use in between the emitter thermal slug and the metal core of the MCPCB, thus lowering the overall system thermal resistance.
3. LED Engin recommends x-ray sample monitoring to screen for solder voids underneath the emitter thermal slug. The total area covered by solder voids should be less than 20% of the total emitter thermal slug area. Excessive solder voids will increase the emitter to MCPCB thermal resistance and may lead to higher failure rates due to thermal over stress.



Reflow Soldering Profile

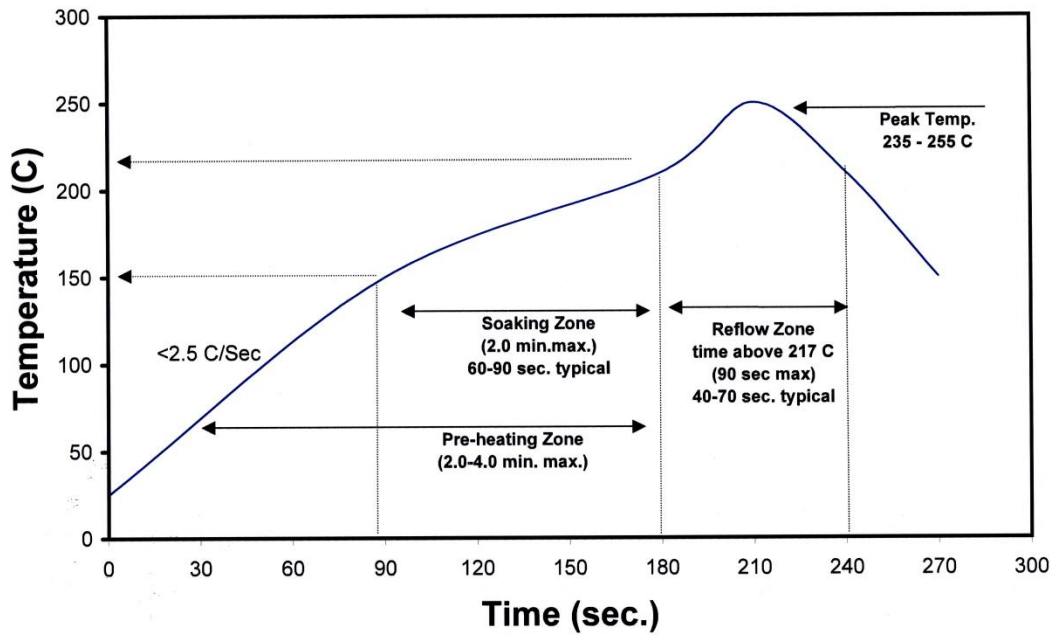

Figure 4: Reflow soldering profile for lead free soldering.

Typical Radiation Pattern

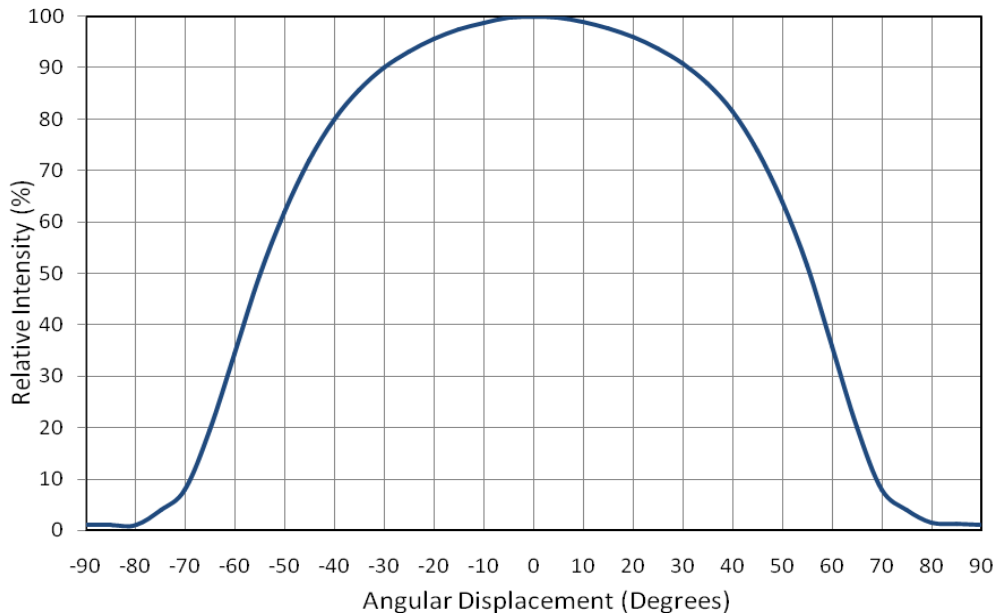

Figure 5: Typical representative spatial radiation pattern.

Typical Relative Spectral Power Distribution

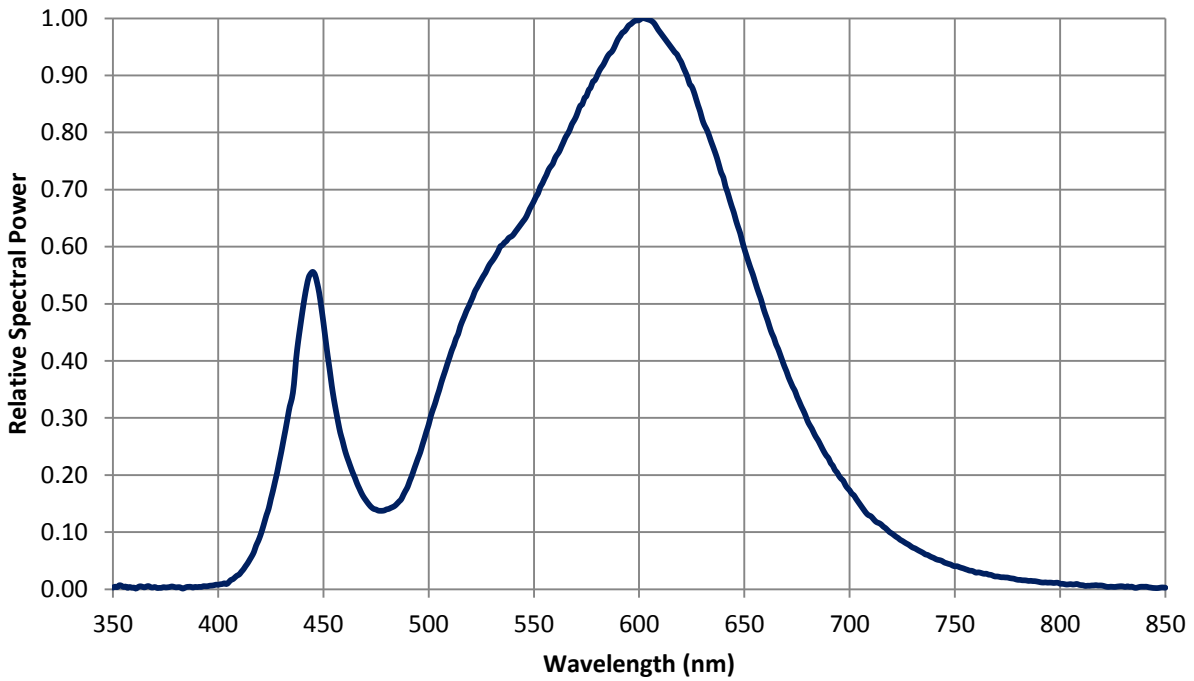

Figure 6: Typical relative spectral power vs. wavelength @ T_C = 25°C.

Typical Forward Current Characteristics

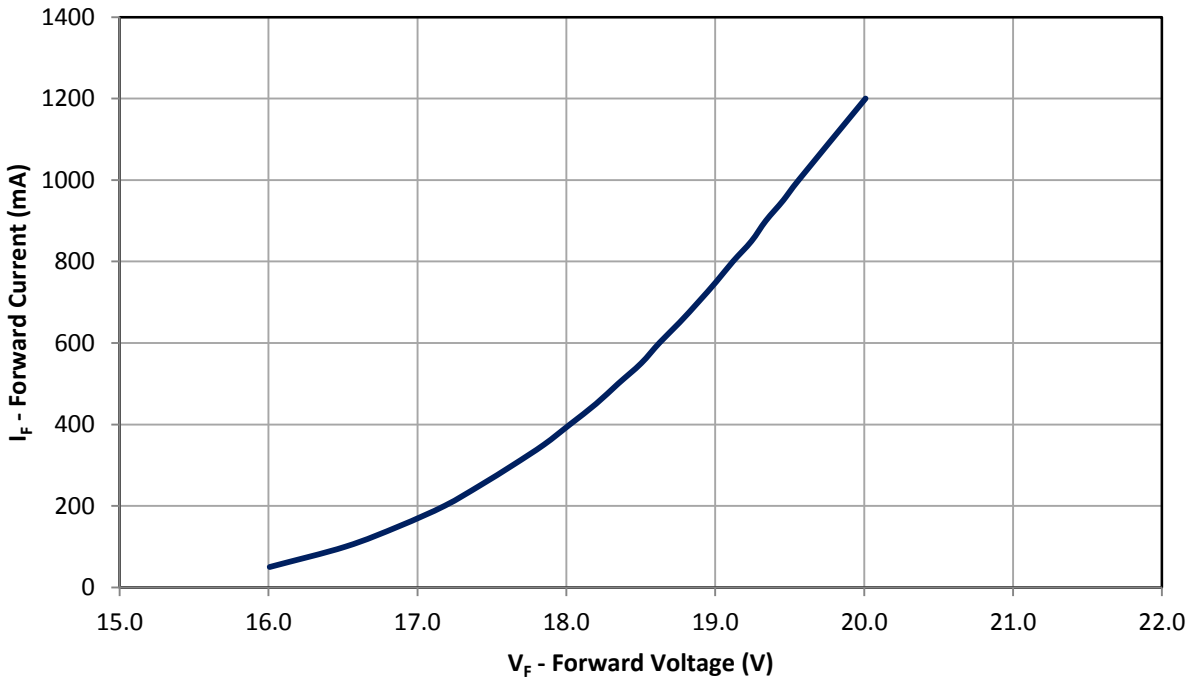

Figure 7: Typical forward current vs. forward voltage @ T_C = at 25°C.

Note:

1. Forward Voltage is measured for a single string of 6 dies connected in series. The LED is configured with 4 Channels of 6 dies in series each.

Typical Relative Light Output over Forward Current

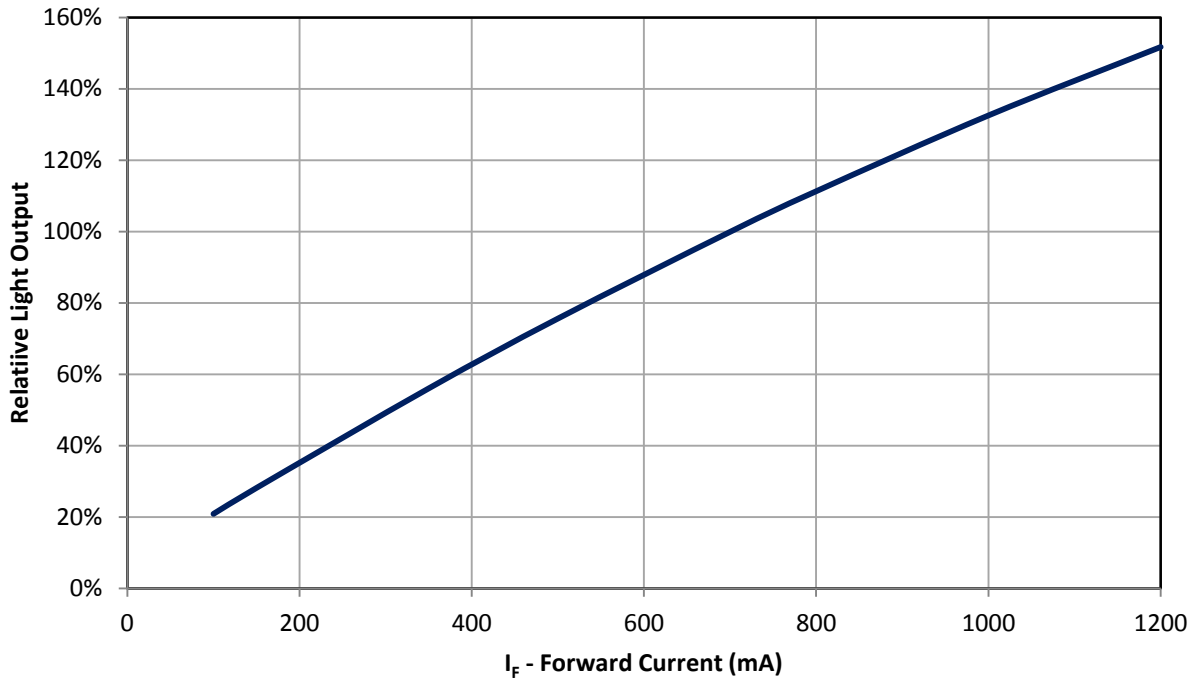

Figure 8: Typical relative light output vs. forward current @ $T_c = 25^\circ\text{C}$.

Notes:

1. Luminous Flux typical value is for all 24 LED dies operating concurrently at rated current per Channel.

Typical Relative Light Output over Temperature

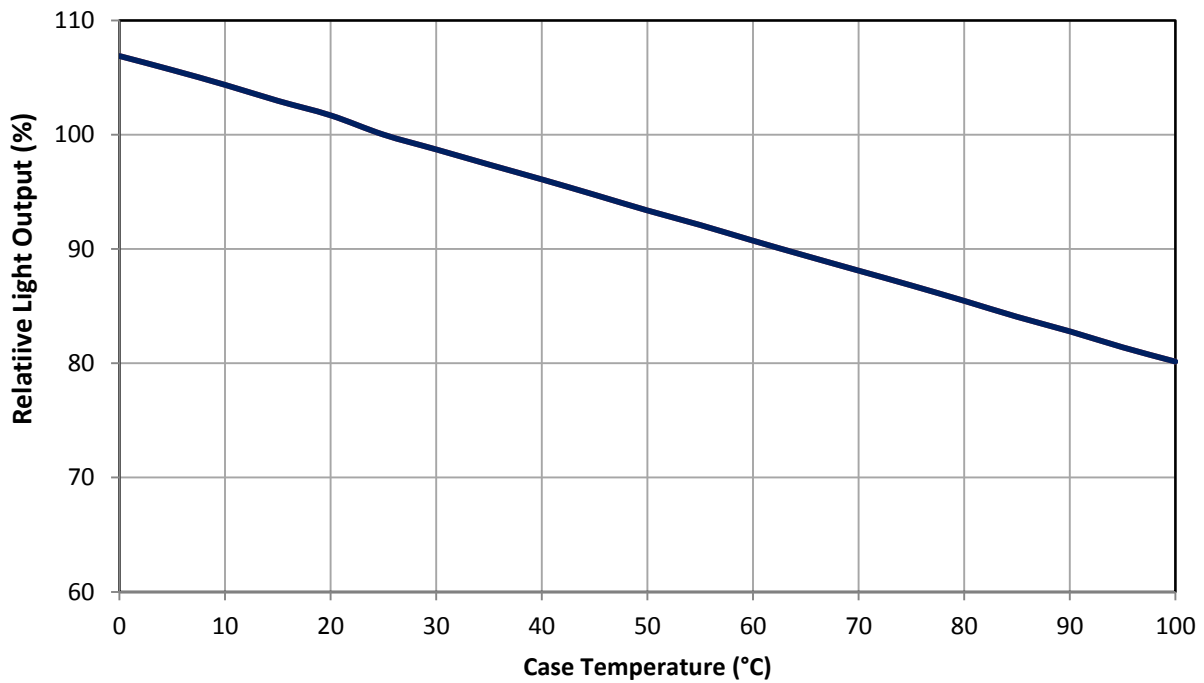

Figure 9: Typical relative light output vs. case temperature.

Notes:

1. Luminous Flux typical value is for all 24 LED dies operating concurrently at rated current per Channel.

Typical Chromaticity Coordinate Shift over Current

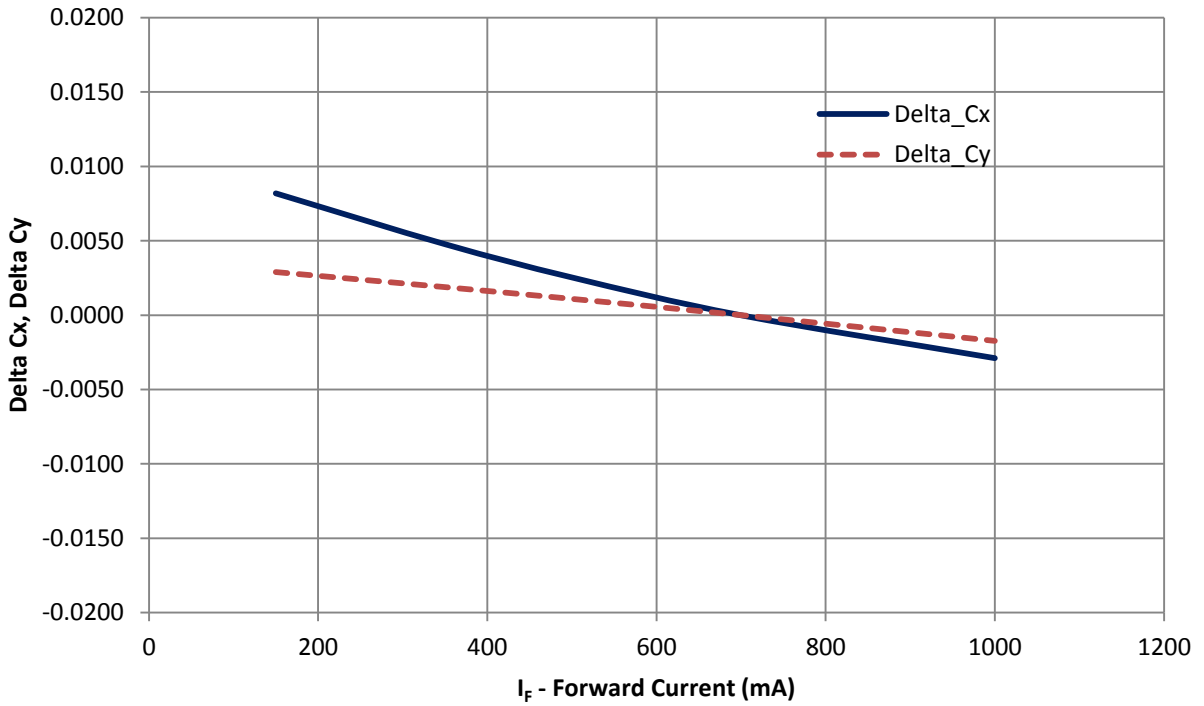

Figure 10: Typical dominant wavelength shift vs. Case temperature.

Typical Chromaticity Coordinate Shift over Temperature

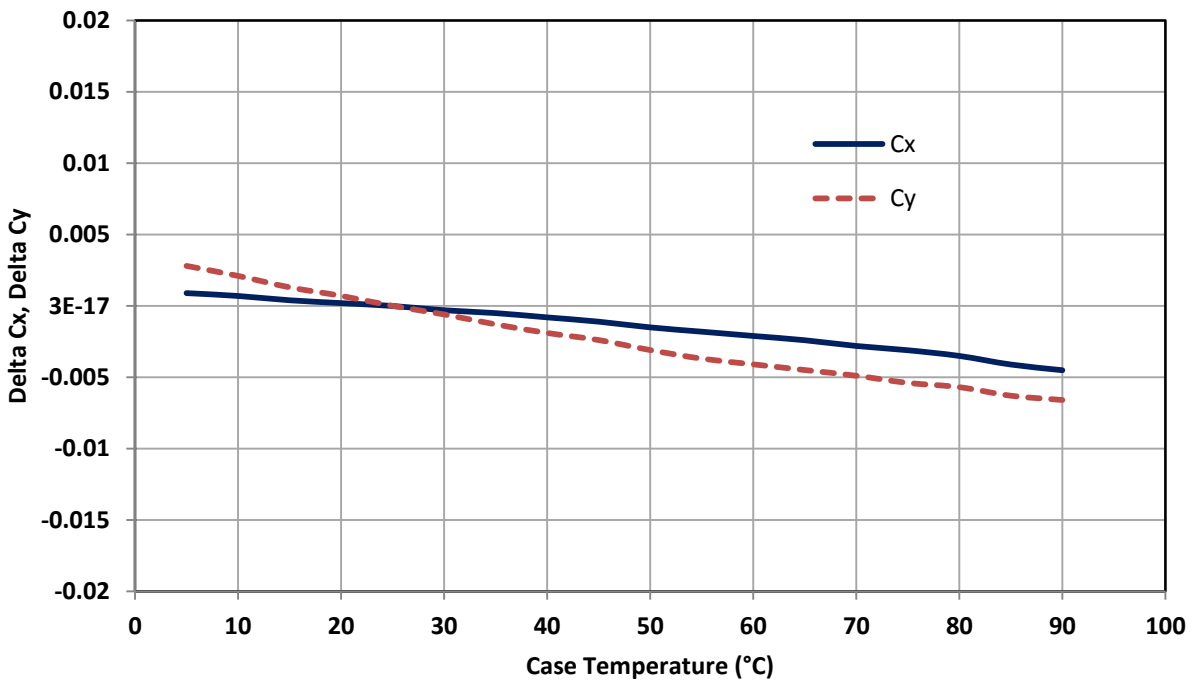

Figure 11: Typical dominant wavelength shift vs. Case temperature.

Current De-rating

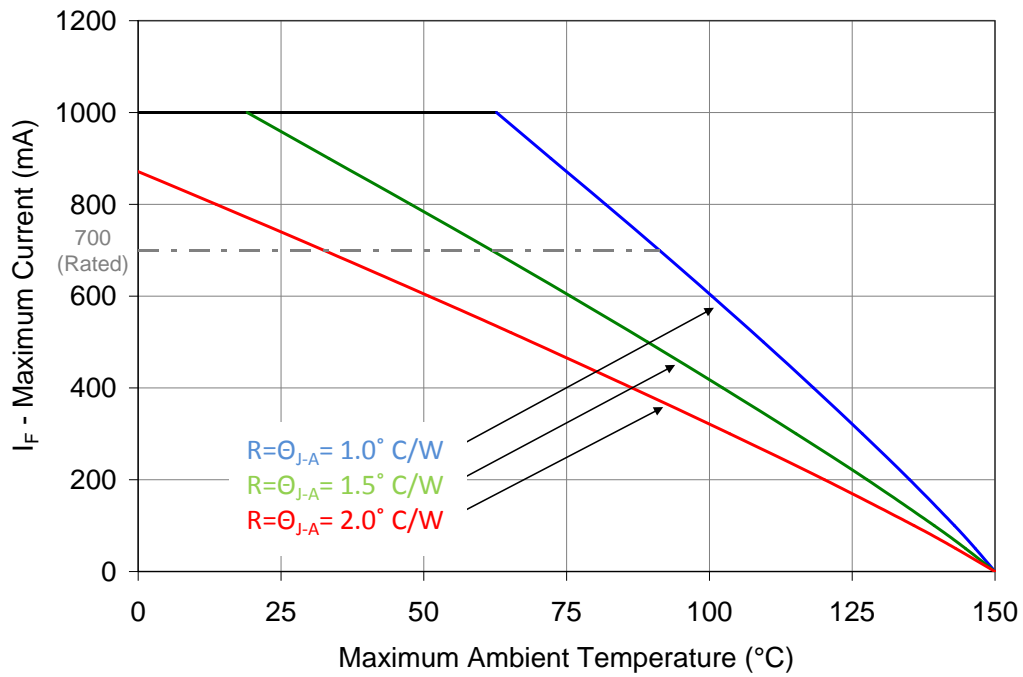

Figure 12: Emitter carrier tape specifications (mm).

Notes:

1. Maximum current assumes that all LED dies are operating at rated current.
2. $R_{\Theta_{J-C}}$ [Junction to Case Thermal Resistance] for the L2P-series is typically 0.6°C/W .
3. $R_{\Theta_{J-A}}$ [Junction to Ambient Thermal Resistance] = $R_{\Theta_{J-C}} + R_{\Theta_{C-A}}$ [Case to Ambient Thermal Resistance].

Emitter Tape and Reel Specifications (mm)

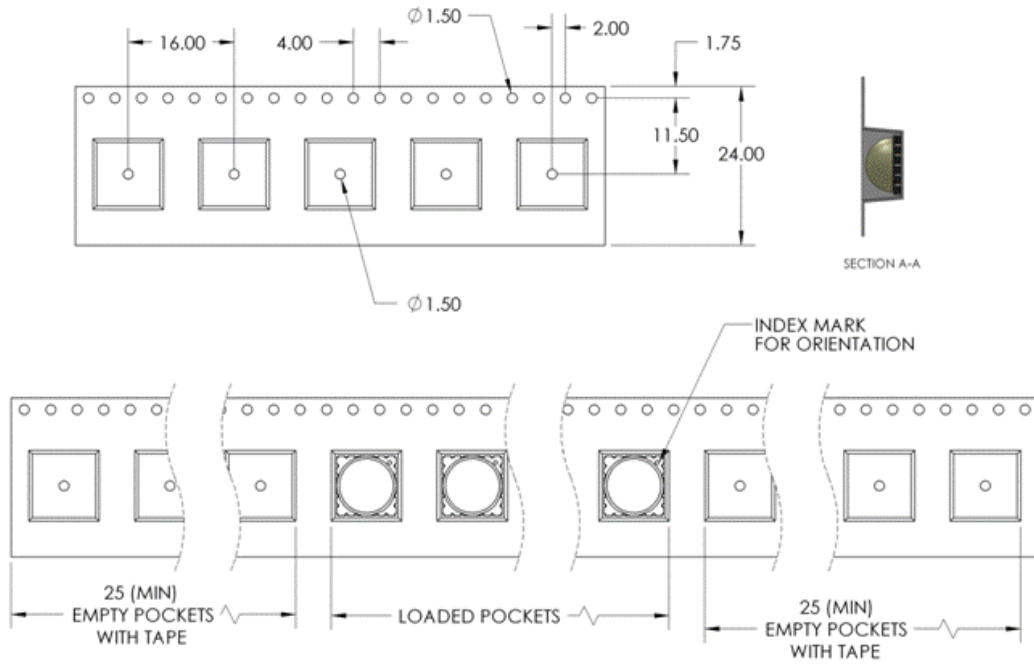

Figure 13: Emitter Reel specifications (mm).

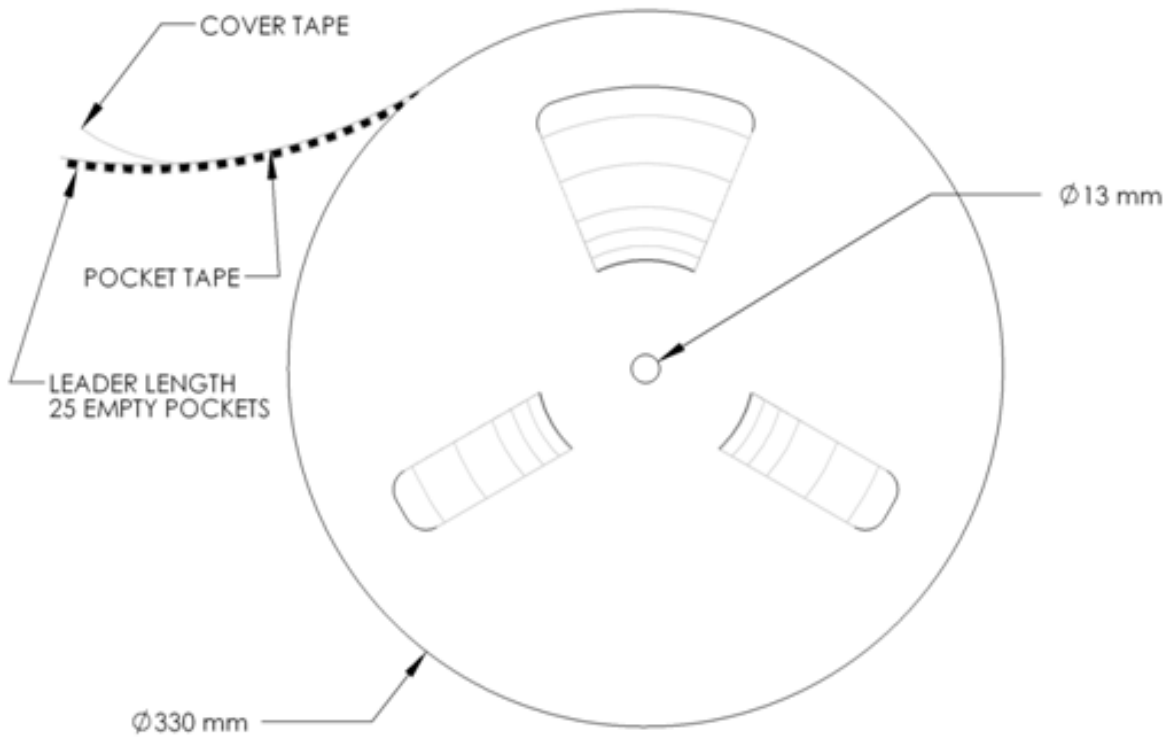

Figure 14: Emitter Reel specifications (mm).

LZP MCPCB Family

Part number	Type of MCPCB	Diameter (mm)	Emitter + MCPCB Thermal Resistance (°C/W)	Typical V _f (V)	Typical I _f (mA)
LZP-DxxxxR	5-channel (4x6+1 strings)	28.3	0.6 + 0.1 = 0.7	18.9	4 x 700

Mechanical Mounting of MCPCB

- MCPCB bending should be avoided as it will cause mechanical stress on the emitter, which could lead to substrate cracking and subsequently LED dies cracking.
- To avoid MCPCB bending:
 - Special attention needs to be paid to the flatness of the heat sink surface and the torque on the screws.
 - Care must be taken when securing the board to the heat sink. This can be done by tightening three M3 screws (or #4-40) in steps and not all the way through at once. Using fewer than three screws will increase the likelihood of board bending.
 - It is recommended to always use plastics washers in combinations with the three screws.
 - If non-taped holes are used with self-tapping screws, it is advised to back out the screws slightly after tightening (with controlled torque) and then re-tighten the screws again.

Thermal interface material

- To properly transfer heat from LED emitter to heat sink, a thermally conductive material is required when mounting the MCPCB on to the heat sink.
- There are several varieties of such material: thermal paste, thermal pads, phase change materials and thermal epoxies. An example of such material is Electrolube EHTC.
- It is critical to verify the material's thermal resistance to be sufficient for the selected emitter and its operating conditions.

Wire soldering

- To ease soldering wire to MCPCB process, it is advised to preheat the MCPCB on a hot plate of 125-150°C. Subsequently, apply the solder and additional heat from the solder iron will initiate a good solder reflow. It is recommended to use a solder iron of more than 60W.
- It is advised to use lead-free, no-clean solder. For example: SN-96.5 AG-3.0 CU 0.5 #58/275 from Kester (pn: 24-7068-7601)

LZP-DxxxxR

5-channel, Standard Star MCPCB (4x6+1) Mechanical Dimensions (mm)

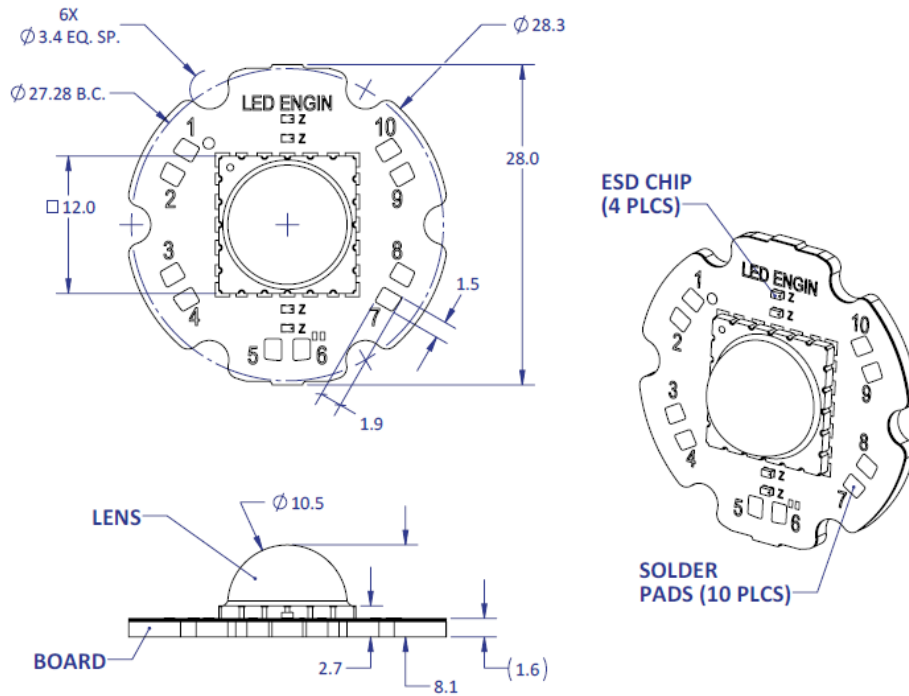

Notes:

- Unless otherwise noted, the tolerance = ± 0.20 mm.
- Slots in MCPCB are for M3 or #4 mounting screws.
- LED Engin recommends using plastic washers to electrically insulate screws from solder pads and electrical traces.
- LED Engin recommends using thermal interface material when attaching the MCPCB to a heat sink.
- LED Engin uses a copper core MCPCB with pedestal design, allowing direct solder connect between the MCPCB copper core and the emitter thermal slug. The thermal resistance of this copper core MCPCB is: R_{ΘC-B} 0.1°C/W

Components used

MCPCB: SuperMCPCB (Bridge Semiconductor, copper core with pedestal design)
 ESD chips: BZT52C36LP (NXP, for 6 LED dies in series)

Pad layout			
Ch.	MCPCB Pad	String/die	Function
1	1	1/EDCBAF	Anode +
	10		Cathode -
2	2	2/JIHGLK	Anode +
	9		Cathode -
3	3	3/ONSQRP	Anode +
	8		Cathode -
4	4	4/TYXWVU	Anode +
	7		Cathode -
5	5	5/M	N/A
	6		N/A

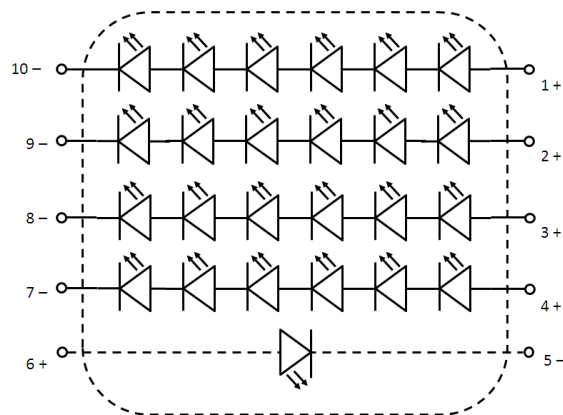

Company Information

LED Engin, based in California's Silicon Valley, develops, manufactures, and sells advanced LED emitters, optics and light engines to create uncompromised lighting experiences for a wide range of entertainment, architectural, general lighting and specialty applications. LuxiGen™ multi-die emitter and secondary lens combinations reliably deliver industry-leading flux density, upwards of 5000 quality lumens to a target, in a wide spectrum of colors including whites, tunable whites, multi-color and UV LEDs in a unique patented compact ceramic package. Our LuxiTune™ series of tunable white lighting modules leverage our LuxiGen emitters and lenses to deliver quality, control, freedom and high density tunable white light solutions for a broad range of new recessed and downlighting applications. The small size, yet remarkably powerful beam output and superior in-source color mixing, allows for a previously unobtainable freedom of design wherever high-flux density, directional light is required.

LED Engin is committed to providing products that conserve natural resources and reduce greenhouse emissions.

LED Engin reserves the right to make changes to improve performance without notice.

Please contact sales@ledengin.com or (408) 922-7200 for more information.