

PART NUMBER	SML-LX1110UPGC-ATR	REV.	A
DATE	E.C.N. NUMBER AND REVISION COMMENTS		REV.
09.07.07	E.C.N. #11440.		A
01.14.11	E.C.N. #11688.		B

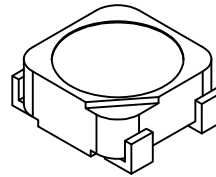

CAUTION: STATIC SENSITIVE DEVICE  
FOLLOW PROPER E.S.D. HANDLING PROCEDURES  
WHEN WORKING WITH THIS PART.

CAUTION: MOISTURE SENSITIVE DEVICE  
PER JEDEC LEVEL 6 STANDARDS

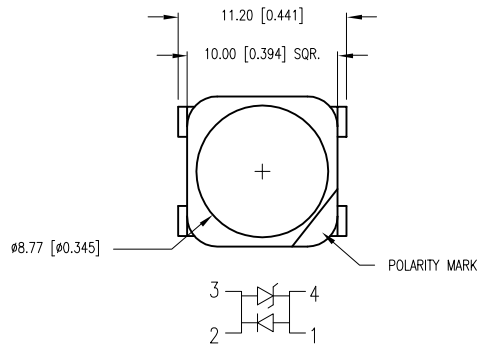
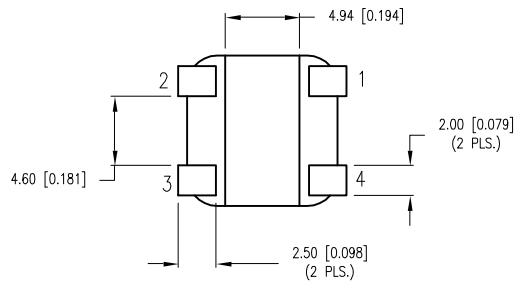
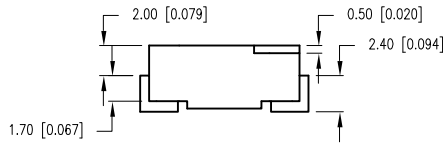

LEAD FREE REFLOW PROFILE

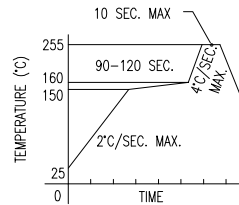

TOTAL TIME ABOVE 220°C IS 60 SECONDS MAX.

ELECTRO-OPTICAL CHARACTERISTICS  $T_A=25^\circ\text{C}$   $I_f=350\text{mA}$

PARAMETER	MIN	TYP	MAX	UNITS	TEST COND
PEAK WAVELENGTH		525		nm	
FORWARD VOLTAGE		3.5	4.0	$V_f$	
REVERSE VOLTAGE	5.0			$V_r$	
AXIAL INTENSITY		20		cd	$I_f=350\text{mA}$
LUMINOUS FLUX		63		lm	$I_f=350\text{mA}$
VIEWING ANGLE		120		2x theta	
EMITTED COLOR:	GREEN				
EPOXY LENS FINISH:	WATER CLEAR				

LIMITS OF SAFE OPERATION AT 25°C

PARAMETER	MAX	UNITS
PEAK FORWARD CURRENT*	500	mA
STEADY CURRENT	350	mA
POWER DISSIPATION	1.2	W
DERATE FROM 25°C	-1.2	mW/°C
OPERATING TEMP.	-40 TO +85	°C
STORAGE TEMP.	-40 TO +85	°C

THERMAL PARAMETERS

PARAMETER	VALUE	UNITS
MAXIMUM JUNCTION TEMPERATURE	110	°C
THERMAL RESISTANCE JUNCTION-CASE	47	°C/W

NOTES:

- ANODE TOWARDS TAPE HOLE.

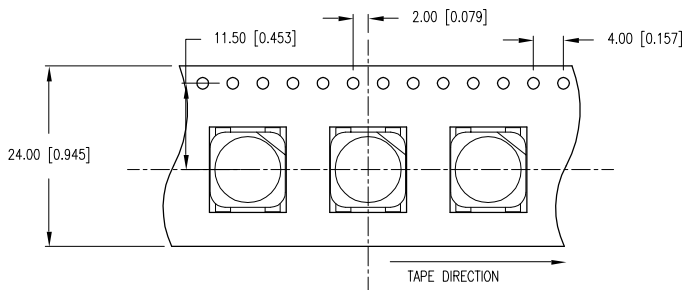

RECOMMENDED SOLDER PAD LAYOUT

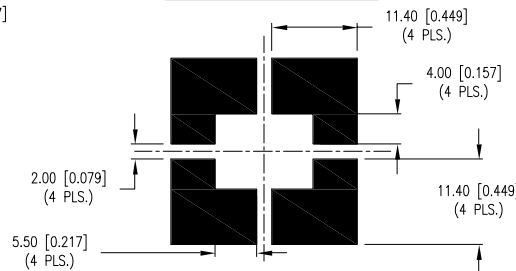

\*UNLESS OTHERWISE SPECIFIED TOLERANCES PER DECIMAL PRECISION ARE: X=±1 (±0.039), X.X=±0.5 (±0.020), X.XX=±0.25 (±0.010), X.XXX=±0.127 (±0.005). LEAD SIZE=±0.05 (±0.002), LEAD LENGTH=±0.75 (±0.030). MIN= +DECIMAL PRECISION MAX.= +0.00 -DECIMAL PRECISION UNCONTROLLED DOCUMENT



290 E. HELEN ROAD  
PALATINE, IL 60067-6976  
PHONE: +1.847.359.2790  
FAX: +1.847.359.6538  
WEB: WWW.LUMEX.COM

PLCC-4 SMT LED, HIGH POWER, 525nm ULTRA PURE GREEN, W/INTERNAL REFLECTIVE CAVITY.

\*\*THE SPECIFICATIONS MAY CHANGE AT ANY TIME WITHOUT NOTICE DUE TO NEW MATERIALS OR PRODUCT IMPROVEMENT.\*\*

CONFIDENTIAL INFORMATION  
THE INFORMATION CONTAINED IN THIS DOCUMENT IS THE PROPERTY OF LUMEX INC. EXCEPT AS SPECIFICALLY AUTHORIZED IN WRITING BY LUMEX INC., THE HOLDER OF THIS DOCUMENT SHALL KEEP ALL INFORMATION CONTAINED HEREIN CONFIDENTIAL AND SHALL PROTECT SAME IN WHOLE OR IN PART FROM DISCLOSURE AND DISSEMINATION TO ALL THIRD PARTIES.

DATE:	07.11.05	DRAWN BY:	JD
PAGE:	1 OF 1	CHKD BY:	KF
SCALE:		APRVD BY:	BC
UNIT:	mm [INCH]		