

SECTION : A-A
SCALE 10:1

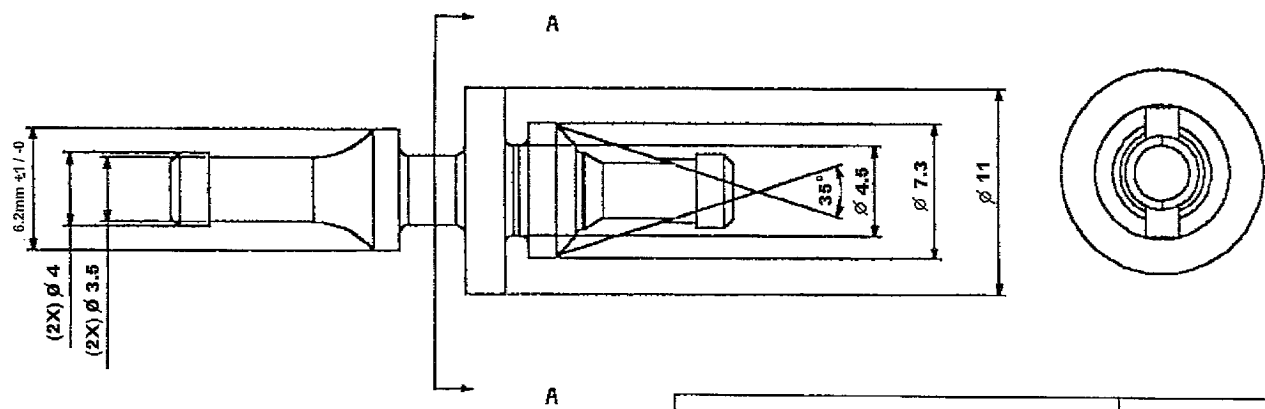

NOTES

- ① MATERIAL TO BE ASTM D-2000 TYPE M3BA407 B13C12Z.
- ② SUFFIX Z: MATERIAL TO HAVE A BASHORE RESILIENCE OF 15% ±4% AND A 35 ±5 DUROMETER A.
3. WARNING: THIS MANUFACTURING PROCESS MAY INCLUDE HAZARDOUS OPERATIONS AND REQUIRE SPECIAL HEALTH AND/OR SAFETY PRECAUTIONS.
- ④ SUGGESTED RUBBER FORMULA:
 EXXON BUTYL 268.....80.0
 DUPONT NORDEL 1070....20.0
 STEARIC ACID.....1.0
 HAF BLACK.....20.0
 SUNPAR 2280.....20.0
 ZINC OXIDE.....5.0
 SULFER.....1.0
 MBTS.....0.5
 TMTDS.....2.0
 CURE @165°C FOR 20 MINUTES
5. 0.15 mm MAX MISMATCH PERMISSIBLE ON PARTING LINE, 2° DRAFT PERMISSIBLE.
6. APPLICATION: FOR USE IN MOUNTING FANS WITH ∅4.3 ±0.3mm HOLES AND FLANGE 3 TO 5.5mm THICK. SUPPORT MOUNTING TO BE ∅4.9 ±0.15mm AND 1 TO 2mm THICKNESS.
7. PARTS TO BE DIP COATED WITH A METHYL SILICONE WATER BASED EMULSION. THE EMULSION CAN BE OBTAINED FROM UNION CARBIDE CORP., SO. CHARLESTON, WV. PRODUCT NO. LE-46 EMULSION.

MECHATRONICS, INC.	Rev.02	2-04-2015
PART NUMBER: VI-1	DESCRIPTION: VIBRATION ISOLATOR	