

EVALUATION KIT

MAXIM MAX180 Evaluation Kit

MAX180 EV Kit

General Description

The MAX180 evaluation kit (EV kit) presents an 80C32-based design that demonstrates the operation of the MAX180, a complete, 8-channel, 12-bit data-acquisition system (DAS). The kit provides a method to quickly evaluate the MAX180's ability to meet system design requirements. After evaluation is completed, the EV kit's PC board layout serves as a proven layout for the new system design. The software, which includes source code, can be easily modified to fit particular applications.

The MAX180 EV kit allows the user to select various MAX180 operating modes and perform conversions through an RS-232 data link. The results are displayed on an IBM-compatible personal computer running a terminal emulator program.

The EV kit also supports the MAX181 analog-to-digital converter (ADC). The MAX181 is similar to the MAX180, except it provides access to both the 6-channel analog multiplexer output and the ADC's input. See the MAX180/MAX181 data sheet for details.

Features

- ◆ 12-Bit, 8-Channel Data-Acquisition System
- ◆ Proven Printed Circuit Board Layout
- ◆ Debugged Software Source Code
- ◆ Operates from a Single +6V to +10V Supply
- ◆ Prototyping Area for the User's Signal Conditioning Circuits
- ◆ Interfaces to IBM-Compatible Computer through RS-232 Port

Ordering Information

PART	TEMP. RANGE	BOARD TYPE
MAX180EVKIT	0°C to +70°C	Plastic DIP-Through Hole

EV Kit

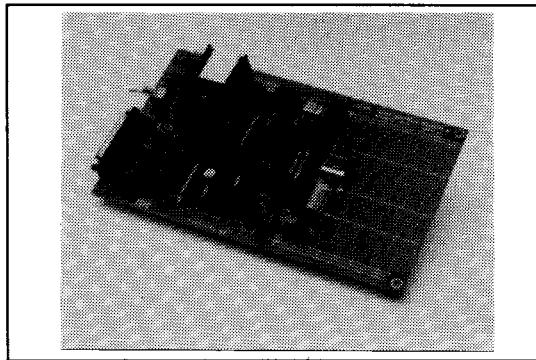

Functional Diagram

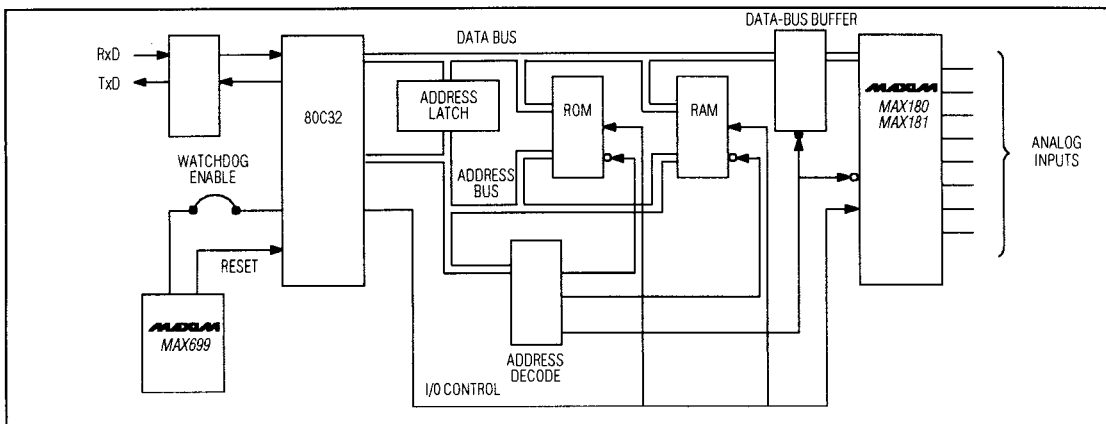

MAX180 Evaluation Kit

Component List

DESIGNATION	QUANTITY	DESCRIPTION
C3, C4	2	15pF capacitors
C1, C5, C6, C6, C9, C10, C11, C12, C13, C16, C17, C19, C20, C21, C23	15	0.1μF capacitors
C2, C7, C15	3	4.7μF 16V capacitors
C8, C18	2	47μF 16V capacitors
C14, C22	2	100μF 16V capacitors
CR1, CR2	2	1N4001 diodes
CR3, CR4	2	1N4148 diodes
CR5	1	1N5817 diode
JU1	1	2-pin power connector
JU2	1	D25 right-angle connector
L1	1	330μH inductor
Q1	1	2N7000
R1, R4	2	10kΩ 5% resistor
R2, R3	2	100kΩ 5% resistors
RP1	1	10kΩ 9-resistor SIP
RP2	1	100kΩ 9-resistor SIP
S1	1	power switch
U1	1	74HCT138
U2	1	80C32
U3	1	74HCT393
U4	1	74HCT373
U5	1	74HCT245
U6	1	MAX180ACPL or MAX181ACPL
U7	1	MAX667CPA
U8	1	MAX699CPA
U9	1	27C64
U10	1	6264LP
U11	1	MAX233ACPP
U12	1	74HCT7266
U13	1	MAX636BCPA
Y1	1	11.059MHz crystal
None	1	28-pin IC socket
None	1	40-pin IC socket
None	1	8 1/2" x 5" PC board
JU4	1	2-pin jumper
JU5	1	3-pin jumper
None	2	shunts
None	1	MAX180/MAX181 data sheet

Quick Start

Setup and operation of the MAX180 evaluation kit involves the following steps:

1. Assemble the printed circuit board using the procedure in the *Assembly Instructions* section.
2. Copy the MAX180 EV kit floppy disk to another disk and store the original in a safe place. Use the copy for normal operation.
3. Read the README file for updates and changes.
4. Connect a cable between a serial port (COM1 or COM2) of the personal computer and the MAX180 EV kit printed circuit board. If a 25-pin (D25) connector is available, a straight-through cable can be used. If only a 9-pin (D9) connector is available, an adapter is required.
5. Start the SERCOMM program on the personal computer and set the indicated active port to agree with the cable location.
6. Turn power on the printed circuit board.
7. Type a SPACE to initialize communication with the EV kit board. The board should respond with a logon message. If not, refer to the trouble-shooting guide in this manual.
8. Enter a "?" for a list of available commands.
9. Connect the input signals to the analog input(s) and the system is ready for operation.

Detailed Description

Board Architecture

Power Supply

The evaluation board can be powered by a 9V alkaline battery or by an external 6V to 10V DC power supply. A MAX667 low-dropout voltage regulator provides the +5V supply required by the other devices on the board.

The -12V is generated on the evaluation board by a MAX636A fixed-output, CMOS, inverting switching regulator.

Supervision

The MAX699 low-cost power-on reset and watchdog timer controller provides on-board supervision for the microprocessor (μP) system. The MAX699 generates a RESET signal at power-on and if the μP's firmware fails to generate a transition at least once a second. Refer to

MAX180 Evaluation Kit

MAX180 EV KIT

the *Watchdog-Enable Jumper Block* section in this manual and the MAX699 data sheet for more information.

RS-232 Interface

The RS-232 interface connects an external terminal to the evaluation board. The MAX233, +5V-powered, dual RS-232 transmitter and receiver interface chip performs the required level shifting for the 80C32's integrated serial port.

One of the RS-232 receivers is not used by the design and is available for prototyping options.

Microprocessor

The 80C32 receives the user's commands over the RS-232 connection, performs the requested command, and then returns the results to the terminal over the RS-232 link. The full list of commands and responses is described in the *Firmware Structure* section of this manual.

Memory for the 80C32 includes a 27C64 8kbyte ROM and a 6264 CMOS 8kbyte RAM. The ROM stores the 80C32's firmware. The RAM is used to buffer the results of analog-to-digital conversions. The firmware's assembly language source code is provided on the diskette.

The address decoding circuitry has associated jumpers that determine the address range of both the device enable signal sent to the ROM and RAM, and of the extra hardware decoding signals (2000-3FFF, 4000-5FFF, 8000-9FFF, A000-BFFF, C000-DFFF) provided for prototype expansion. The *Jumper Options* section discusses setting this jumper.

The MAX180 data lines are buffered and attached to the 80C32's data bus. Its chip-select signal (\overline{CS}) is generated by the address decoding circuitry. The eight data input/output (I/O) pins, the three address pins (A0-A2), the BIP pin, and the DIFF pin are multiplexed onto the data bus.

The 80C32's 8-bit data bus and the control signals (PSEN, RD, WR, and ANYRD) are provided at labeled pads for prototyping.

The 80C32's PORT 1 (P1) is a general purpose I/O port. The bits have been assigned the following uses:

- Bit 0 - Programmed Heartbeat to the MAX699 Watchdog
- Bit 1 - High-Byte Enable (HBEN) to the MAX180
- Bit 2 - BUSY from the MAX180
- Bit 3 -
- Bit 4 -
- Bit 5 - } Available for Prototyping
- Bit 6 - }
- Bit 7 - }

The 80C32 uses an 11.059MHz crystal. This frequency allows the μ P to execute most of its instructions in 1.085 μ s and provides an exact integer multiple for the standard baud rates.

Frequency Divider

The μ P's oscillator output is divided by a 74HCT393 and used to produce the clock signal for the MAX180. The MAX180 clock has a 50% duty cycle and runs at 1.382MHz (11.059MHz divided by 8).

MAX180 Complete, 8-Channel, 12-Bit Data-Acquisition System

The MAX180's analog input pins are brought out to eight pairs on solder pads, with the following markings on the silk screen:

AIN0
AIN1
AIN2
AIN3
AIN4
AIN5
AIN6/MUXOUT
AIN7/ADCIN

The MAX180's MODE pin is permanently pulled up to +5V, which places the MAX180 into its I/O port mode.

Jumpers JU1 and JU2 (see Figure 1a) allow reference and offset adjustments.

Jumper JU3 (see Figure 1a) selects either an internal or external reference.

Firmware Structure

The source code for the evaluation board's firmware is provided on a diskette. The program is in assembly language and operates with an 80C32 assembler. The program being executed in the ROM will be referred to as the monitor.

The monitor enters its main control loop after initialization. This code starts at the label "main." Main calls "get_command" which handles keyboard entry for the monitor. Commands that simply change the state of the monitor (for instance the "H" command, which is used to set the output mode to hexadecimal) are handled within "get_command." Commands requiring action, such as making analog-to-digital conversions or testing RAM, return function request codes to main. Main then calls the function associated with the request code.

80C32/MAX180 Interface

The MAX180 is connected to the 80C32 with the μ P's 8-bit data bus. The MAX180 appears to the μ P as a single

MAX180 Evaluation Kit

register at any address in the E000...F000 range in either the CODE or DATA memory segments.

In addition, the MAX180's HBEN and $\overline{\text{BUSY}}$ pins are connected to two of the 80C32's PORT1 pins.

A write to the MAX180 starts a conversion. The bit pattern written to the MAX180 conveys the following information:

BIT 0	A0	} Analog Input Channel Select {0...7}
BIT 1	A1	
BIT 2	A2	
BIT 3	BIP	Bipolar (not unipolar select)
BIT 4	DIFF	Differential (not single-ended select)
BIT 5	Ignored	

The MAX180's $\overline{\text{BUSY}}$ pin is monitored to detect conversion end. The MAX180 is read twice at the end of the conversion to obtain both data bytes that make up the full 12-bit word. The first read is made with HBEN low to get the least significant byte of the conversion. The second read is made with HBEN high to get the upper four bits (most significant nibble) of the conversion.

The following code has been extracted from the EV kit's source code. It is the conversion routine for the MAX180. It assumes the current channel number is stored in the channel register and has a value of {0...7}. It further assumes that the a2d_flags registers have the DIFF and BIP bits set to indicate what combination of BIP and DIFF the MAX180 should be in when it performs the conversion. See the MAX180/MAX181 data sheet for further description of these operating modes.

Application Information

Attaching the Terminal

The MAX180 evaluation board attaches to a dumb terminal or a personal computer running a terminal emulation program. The board is wired as data communications equipment (DCE) and expects to be connected to data terminal equipment (DTE). A standard straight-through cable is used to attach the board to a personal computer running emulation software.

The following diagrams show the connections between the terminal and the MAX180 EV kit.

	stt1	INPUT/OUTPUT DEFINITIONS	
IO_PORT	reg	P1	
TIC_TOC		01h	; watchdog-timer reset pulse
b_TIC_TOC	reg	P1.0	;
HBEN		02h	; A2D converter: : High-byte Enab
b_HBEN	reg	P1.1	;
nBUSY		04h	; A2D converter: : -BUSY
b_BUSY	reg	P1.2	;
max180	reg	0e000h	; A2D converter is at {E000h. . .FFFPh}
a2d_start	reg	1ch	; starts A2D conversion pattern
a2d_stop	reg	1dh	; ends A2D conversion pattern
a2d_hi	reg	1eh	; A2D conversion result MSB
a2d_low	reg	1fh	; A2D conversion result LSB
a2d_flags	reg	21h	; conversion flags
bip_flag	reg	21h.3	; set=bipolar; rest=unipolar
diff_flag	reg	21h.4	; set=differential; reset=single-ended
channel	reg	23h	; current channel register

MAX180 Evaluation Kit

MAX180 EV KIT

```
convert      TTL2 'subroutine - CONVERT"
             equ  $
             push A
             push DPH
             push DPL
             ; Select the channel and the differential-single-ended mode and t
             ; bipolar/unipolar mode.
             mov  IO_PORT
                 #TIC_TOC+nBUSY           ; turns off the HBEN bit
                 ; so a conversion can start
                 A, channel               ; gets the channel # into the 3 LSBs
                 A, a2d_flags            ; OR in the BIP and DIFF bits
                 DPTR, #max180          ; points at the A2D converter
                 @DPTR, A                ; starts the conversion
             ; first waits for BUSY to go LOW, then waits for BUSY to go HI
conv_wait4low equ  $                       ; If these WAITS take
             jb   b_nBUSY, conv_wait 4low ; too long, the watchdog
conv_wait4hi  equ  $                       ; timer resets the  $\mu$ P.
             jnb  b_nBUSY, conv_wait 4hi
             ; fetches and stores the LS byte and the MS nibble
             movx A, @DPTR                 ; fetches the LS Byte
             mov  a2d_low, A              ; stores it

             mov  A, #nBUSY+HBEN         ; enables the high byte
             movx A, @DPTR                 ; fetches the MS byte
             anl  A, #0fh                 ; turns off the high nibble
             mov  a2d_hi, A              ; stores the MS nibble

             pop  DPL
             pop  DPH
             pop  A
ret
```

MAX180 Evaluation Kit

For D25 (25-pin) to D25 connectors (a straight-through cable can be used):

Terminal Connector (DTE)		MAX180 Connector (DCE)	
Signal	Pin	Pin	Signal
Ground	1 -----	1	Ground
TxD	2 -----	2	RxD
RxD	3 -----	3	TxD
RTS	4 -----	4	RTS
CTS	5 -----	5	CTS
DSR	6 -----	6	DSR
Ground	7 -----	7	Ground
DCD	8 -----	8	DCD
DTR	20 -----	20	DTR
RI	22 -----	22	RI

For D9 (9-pin) to D25 (25-pin) connectors (standard adapters are available for this configuration):

Terminal Connector(DTE)		MAX180 Connector (DCE)	
Signal	Pin	Pin	Signal
DCD	1 -----	8	DCD
RxD	2 -----	3	RxD
TxD	3 -----	2	TxD
DTR	4 -----	20	DTR
Ground	5 -----	7	Ground
DSR	6 -----	6	DSR
RTS	7 -----	4	RTS
CTS	8 -----	5	CTS
RI	9 -----	22	RI

For Macintosh mini 8-pin to D25 connectors:

Terminal connector(DTE)		MAX180 connector (DCE)	
Signal	Pin	Pin	Signal
DTR	1 -----	20	DTR
CTS	2 -----	5	CTS
TxD	3 -----	2	TxD
Ground	4 -----	7	Ground
RxD	5 -----	5	RxD
not used	6		
not used	7		
not used	8		

The board supplies DATA SET READY (DSR), CLEAR TO SEND (CTS), and CARRIER DETECT (CD) to the interface at all times when it is powered up.

The board ignores the REQUEST TO SEND (RTS) signal from the terminal. The signal is brought at RS-232 voltage levels to a marked pad, and can be used for prototyping.

As the board is shipped, the DATA TERMINAL READY (DTR) signal is also ignored by the board. If the DTE-CTL jumper is cut, however, DTR turns the board power on and off, assuming the on/off switch is in the on position. This option causes the board to power down when you turn off your dumb terminal or exit your terminal emulation program. This function is useful for battery-operated systems.

Autobaud

Before turning on the evaluation board, set your terminal for an 8-Bit, no-parity, full-duplex operation. You can set your terminal to any standard baud rate from 300Bd to 9600Bd.

Maxim supplies the Sercomm terminal emulation program for operation with Maxim's EV kits. The SERCOMM.EXE program on the diskette can be copied to a hard disk drive or started from the floppy disk. The program will display a help menu for the available options.

When the board is first powered up, the firmware does some initialization and then enters an automatic baud rate detection loop. The autobaud routine examines the first character received to determine the incoming baud rate.

THE FIRST CHARACTER YOU TYPE AFTER POWER-UP MUST BE A SPACE.

The space character (20 hex) is expected by the autobaud routine. Sending a different character will almost certainly cause the board to calculate a baud rate different from that of your terminal, and gibberish will appear on your screen. If you inadvertently press another key first, turn the board off, then back on to correct the problem.

Once the communication link is established, the monitor displays its sign-on banner and a prompt. The banner consists of the copyright notice and the ROM version information. The message will look something like this:

```
MAXIM INTEGRATED PRODUCTS, 1992
Version 1.00 Released January 9, 1992
```

After the log-in procedure is completed, the system displays a descriptive prompt.

Prompt

The monitor's prompt takes the form:

```
"MAX180: < current output format:
current input mode: channel number > "
```

where current output format is

MAX180 Evaluation Kit

MAX180 EV KIT

HEX, DEC or BIN,
the current input mode is either
UNI or BIP,
and the current channel number is in the following set:
{0..7} for single-ended operation
or
{0/1, 1/0, 2/3, 3/2,
4/5, 5/4, 6/7, 7/6} for differential operation.

The monitor has commands to set the current output and input modes and the current channel number. These commands will be discussed in the *Command Set* section.

You can determine the monitor's current operating mode by simply looking at the prompt. For instance, if the prompt reads

```
MAX180:HEX:BIP:0/1 >
```

you know that the MAX180 is encoding data using signed twos-complement 12-bit coding and the output format is in ASCII hexadecimal. The input is in differential mode using the channel 0/1 analog input pair.

Command Set

The monitor has an 8-byte input buffer. The monitor will return the error message "?" if more than 8 characters are sent to the monitor without an ENTER (the carriage return character). You will also receive the error message if the monitor receives an unknown command. All commands are single characters followed by ENTER (carriage return). The "?" command accesses help. The help screen lists all the commands displayed in functional groups, as follows:

? - Help screen

Display Output Mode Selection Commands:

- H - Hexadecimal format
- D - ASCII decimal format
- ^B - Binary values (12bits/2bytes, MSByte 1st)

MAX180 Conversion Mode Selection Commands:

- B - Bipolar mode
- U - Unipolar mode

MAKE CONVERSION Commands:

- M - Makes a single conversion and displays result; a NULL command (i.e. just CR) also makes a conversion.
- C - Continuously converts and displays until any key is pressed

Channel Select Commands:

- 0...7 - Selects channel number
- DI - Differential input mode
- SE - Single-ended input mode

RAM Related Commands:

- R - RAM test
- S - Stores conversions in RAM buffer until full
- O - Outputs the values stored in RAM buffer

The RAM Related commands "S" and "O" appear only if the RAM chip is on the evaluation board.

The Display Output Mode Selection commands are used to set the display format of the MAX180 conversion results. When the MAX180 performs a conversion, the result is always 12 bits long. The 12 bits of data are presented as follows:

H - Hexadecimal format

The 12-bit value is converted into ASCII hexadecimal format with a dynamic range of '000' to 'FFF.' The current input mode has no effect on the output data in HEX mode. This means 'FFF' equals a count of -1 if the current input mode is bipolar (BiP) or 4095 counts if the input mode is unipolar (UNI).

D - ASCII Decimal format

The 12-bit value is converted into ASCII decimal format. The dynamic range depends on the current input mode, as follows:

INPUT MODE	OUTPUT VALUE RANGE (V)
Unipolar (UNI)	0 ... 4.999
Bipolar (BiP)	-2.500 ... 2.499

^B (Control B) - Binary values (12bits/2bytes, MSByte 1st)

The ^B command causes the binary values to be output as raw binary data (i.e. unformatted) in a 2-byte packet. The first byte has 4 leading 0s followed by the most significant 4 bits of the conversion. The second byte holds the conversion's least significant 8 bits.

As with the HEX output mode, the input mode does not change the data's format. The dynamic range of the output, expressed as a binary-bit pattern, is:

```
0000 0000 0000 0000 ... 0000 1111 1111 1111
```

MAX180 Evaluation Kit

Input mode is useful when capturing data to a disk log file, but do not send this data to your display screen, because the binary values will have unpredictable effects on your screen.

The Conversion Mode Selection commands are used to tell the MAX180 which data transfer function it should use to present the conversion result.

B - Bipolar mode

In bipolar mode, the MAX180 outputs a signed 12-bit twos-complement number. The MAX180 is now operating in differential mode. See the MAX180 data sheet for a discussion of differential input, output data format, dynamic performance, and unipolar/bipolar transfer functions.

U - Unipolar mode

Unipolar mode is the monitor's default operating mode. The input voltage ranges from 0V to +4.999V.

The following commands are used to select the current analog input configuration:

{0..7} - Selects the current channel

The monitor is commanded to make the typed number the current channel. The monitor will respond by changing the prompt to the requested channel number. If the current input mode is differential, the response will be with the channel pair number. That is, if channel 0 is selected, the prompt will reflect channel '0/1' as the current channel.

DI - Differential input mode

Analog input channels are paired. Instead of 8 single-ended analog channels, there are 4 differential analog channels.

Note: The differential input does not imply bipolar coding, which is selected with the B command.

SE - Single-ended input mode

Analog input channels are single ended; that is, the input voltage is measured with respect to analog ground rather than another one of the MAX180's input channels.

Note: The single-ended input does not imply unipolar coding, which is selected with the U command.

The main function of the EV kit is to cause the MAX180 to make a conversion and to display the results.

M - Makes a single conversion and displays result. A carriage return with no other character also makes a conversion.

The MAX180 is commanded to make one conversion in the current input mode, and the result is displayed in the current output mode.

C - Continuously converts and displays result

Conversions continue until a key is pressed.

If your terminal cannot accept the data at full speed, data will be lost. The XOFF or any other character will terminate this command. If you have a problem, try operating your terminal at a slower baud rate. This warning also applies to the RAM output 'O' command.

The RAM Related commands are useful when the optional 8kbyte RAM chip is installed in the evaluation board.

R - RAM test

The monitor continuously fills the RAM with the following bit patterns and then reads the data back to verify RAM integrity.

BINARY	HEX
00000000	00
11111111	FF
01010101	55
10101010	AA

The RAM test runs until the monitor receives any character. The results are displayed as errors, which are detected at the beginning of each test pattern run.

S - Stores conversions in RAM buffer

4096 conversions are made in the current mode (UNI or BIP) and the results are stored in the RAM as raw 12-bit data.

O - Outputs the values stored in RAM buffer

The RAM's current contents are formatted through the current output mode (HEX, DEC or BIN), and the results are sent to the terminal.

There are a few things to keep in mind when outputting the contents of the RAM buffer. If you use decimal formatting, do NOT change between UNI and BIP input modes between the time you take a sample (S) and do the output (O), because the output coding will not match the input coding.

MAX180 Evaluation Kit

MAX180 EV KIT

Using the MAX181

The EV kit can also be used with the MAX181 DAS. Contact Maxim for a sample of the MAX181 to replace the MAX180 on the printed circuit board. The MUXOUT and ADCIN pins of the MAX181 must be either shorted together or connected to an external amplifier. Figure 18 of the MAX180/MAX181 data sheet illustrates typical application circuits.

The design software does not detect the presence of a MAX181. The difference in operation would occur whenever < channels 6 or 7 are selected >. The conversion readings are determined by the external circuitry. Table 1 of the MAX180/MAX181 data sheet outlines the input multiplexer's state.

Power Requirements

The MAX180 evaluation board can be powered by a 9V alkaline battery or by an external DC power supply. If an external power supply is used, the input voltage must be between 6.0V and 11.0V.

The evaluation board draws 50mA to 80mA when operated with normal memory-cycle lengths. The current requirements increase with extended memory-cycle decoding and with current demands of the circuitry added in the prototype area. The total current load must not exceed the limits of the MAX667. Refer to the MAX667 data sheet if additional current is being drawn by your circuits.

Jumper Options

Two jumper blocks permit shunts to be set on or off to affect the board's operation. In addition, 3 traces can be cut and a wire jumper can be soldered in to set options on the board.

Cycle-Length Jumper Block

In the normal configuration, the address decoder's outputs (U1, 74HCT138) are asserted only for the duration of the 80C32's RD, WR or PSEN signals. This enables the ROM and RAM devices only for short periods of time. For this mode, place the JU5 shunt between pins 1 and 2.

If U1's pin 5 is grounded, the output stays asserted from the time memory in a specific block is first accessed until memory in another block is accessed. This increases the board's current requirements to approximately 150mA, and the input voltage range must be limited (see the MAX667 data sheet). It is recommended that this option be used only if additional circuits require long address-enable signals.

Watchdog-Enable Jumper Block

Watchdog-enable jumper JU4 is normally installed. In this watchdog-enable mode, the μ P will automatically reset if its firmware fails to send a heartbeat transition to the watchdog. Remove this shunt to defeat the automatic reset feature (usually for firmware development).

DTE-Control Jumper

If the DTE-control jumper is cut, use the terminal's DTR signal to turn the evaluation board on and to reset it. The board ignores the DTR if the jumper is not cut.

External Reference Jumper (JU3)

JU3 is shorted when the board is shipped, which enables the internal reference. Cut the trace between the pads on the solder side of the PC board to disable the internal reference. An external reference can then be applied to the JU3 pad closest to the MAX180.

Reference and Offset Adjust (JU1, JU2)

JU1 and JU2 are shorted on the evaluation board, which applies VDD to the respective inputs. Either trace can be cut (on the solder side of the PC board), and a pad is provided for each to allow the reference adjust and offset adjust to be actively driven.

Board Assembly

The MAX180 EV kit is shipped unassembled. The assembly tools needed are a small tipped, grounded soldering iron, wire cutters, and a screw driver. You should have basic prototyping skills such as soldering and determining component values. Follow the directions carefully and verify your work at each step.

Note: Trim the leads of the diodes, resistors, and capacitors after they are soldered in position.

1. Remove the board and parts from the box. Check against the component list to verify all parts are present.
2. Insert and solder the diodes in place. Be sure to align the cathode band on the diode with the markings on the printed circuit board.

CR1, CR2 1N4001
CR3, CR4 1N4148
CR5 1N5817

3. Insert and solder the resistors:

R1, R2 10k Ω 5%
R3, R4 100k Ω 5%

MAX180 Evaluation Kit

4. Insert and solder the 28-pin socket for U9, the 27C64 ROM.
5. Insert and solder the 40-pin socket for U6, the MAX180.
6. Insert and solder the nonpolarized capacitors.

C3, C4	15pF
C1, C5, C6, C9, C10,	
C11, C12, C13, C16, C17,	
C19, C20, C21, C23	0.1 μ F
7. Insert and solder the polarized capacitors. MAKE SURE THE POSITIVE TERMINAL OF THE CAPACITOR ALIGNS WITH THE POSITIVE PAD (marked with a + sign).

C2, C7, C15	4.7 μ F
C8, C18	47 μ F
C14, C22	100 μ F
8. Insert and solder the 11.059MHz crystal.
9. Insert and solder the 330 μ H inductor L1.
10. Mount and solder into position the power switch, the power connector JU1, and the 25-pin RS-232 connector JU2.
11. Mount the battery holder into position using the double-sided tape. Make sure the 2 terminal leads go through the board. Solder the terminal leads.
12. Insert and solder Q1, the 2 resistor SIP packages RP1 and RP2. Align the marked end of the SIP with the marked end of the outline on the board.

RP1	10k Ω
RP2	100k Ω
13. Insert and solder the 2N7000 transistor. Align the case with the outline drawn on the printed circuit board.
14. Insert and solder the following devices. Align the notched end of the package with the notched end of the outline on the board. Sockets may be soldered in for each device.

U1	74HCT138
U2	80C32
U3	74HCT393
U4	74HCT373
U5	74HCT245
U7	MAX667
U8	MAX699
U10	6264
U11	MAX233
U12	74HCT266
U13	MAX636

15. Insert the 27C64 ROM and the MAX180 into their sockets.
16. Mount the 2-pin Jumper Block on JU4. Place a shunt across the two pins.
17. Mount the 3-pin Jumper Block on JU5. Place a shunt across the two inside pins.

When assembly is complete, carefully examine the board for misinserted components and soldering faults. Remove excess flux and read the setup instructions.

Trouble-Shooting Guide

Digital Section

With a terminal attached to the D25 connector, apply power to the evaluation board. Type a space before typing any other character. You should see the sign-on banner displayed on your screen in response to the space. If you do not get the sign-on banner, use the following suggestions to isolate the problem.

If gibberish appears, either the terminal is not set to 8-bit, no-parity operation, or the first character sent to the board was not a space. Reset the board and press the spacebar. If each character you type appears twice, your terminal is in half-duplex mode. Change the setting to full duplex.

If there is no response check the following:

Terminal Connection

Remove the RS-232 cable from the evaluation board and connect pins 2 and 3 together. When you type on the terminal, you should see the characters echoing on the screen. If not, the problem is somewhere in the terminal or cable.

Power

Is there 5V on the +5V prototype pads? Measure the +5V on the printed circuit board. Measure between the DGND and +5V traces found on the edge of the prototype area. If it is lower than 4.95V, verify the following:

Verify that the input voltage to the MAX667 (pin 8) is greater than 6.0V. If not, the problem is in the power source.

Are you using a battery? Is the battery good? Try a fresh 9V alkaline battery. Its loaded output voltage is typically greater than 7V.

If you are using an external power supply, is it turned on and connected with the proper polarity (positive to VIN).

If the MAX667 input (pin 8, > 6V) is okay but its output (pin 2) is low, check the following:

MAX180 Evaluation Kit

MAX180 EV Kit

Has the DTE-CTL trace been cut to enable DTR control of power? If yes, is DTR being asserted by your terminal? Reconnect the DTE-CTL pads and try again. Pin 5 of the MAX667 needs to be pulled down to 0V.

If the MAX667 output is 0V and it is warm, the output might be shorted. Examine the board for shorts and verify that all devices are inserted correctly.

Microprocessor-Related Problems

If the 5V supply is okay, use a scope to check pin 5 of U3 (the 74HCT393) to verify that the oscillator is running. If not, the 80C32 or the reset circuit could be at fault.

Verify that P1.0 (pin 1 of the 80C32) toggles regularly. If not, the basic digital system is not operating properly. Check the following:

Verify that the RESET circuit is operating properly. Pin 7 of the MAX699 should be low for 100ms after power-up, then go high. If not, make sure that its output is not overloaded.

Verify that the ADO address line has a signal on it. If the μ P is functioning properly, the address lines will change states regularly.

Verify that the μ P control lines are not overloaded. With a scope, observe the operation of the $\overline{\text{PSEN}}$, ALE, $\overline{\text{WR}}$, and $\overline{\text{RD}}$ lines. The first two will toggle about every microsecond. The $\overline{\text{WR}}$ and $\overline{\text{RD}}$ lines will remain high while waiting for a character from the terminal.

Verify that the lower 8 bits of the address are being latched by the 74HCT373.

Verify that the ROM output of the address-decode logic (pin 15 of the 74HCT139) toggles low during the $\overline{\text{PSEN}}$ pulse.

Verify that the signals are inverted as they are passed through the MAX233 (see the schematic for pins) and that the RS-232 levels on the 25-pin connector are correct.

Analog Section

If the board establishes communications with the terminal but fails to make conversions, check the following:

If the system hangs when you command it to do a conversion, check pin 29 of the MAX180 to be sure it is receiving its divided-down clock.

If the board returns readings but not the proper values:

Check the +5V (pin 40) and -12V (pin 15) of the MAX180/MAX181. Correct if either are out of the MAX180 specifications.

Check the MAX180's reference voltage (pins 9 and 11). It should be -5.00V. Check if jumper JU3 is out of range.

Check that the input voltage is on the active input channel. The channel can be determined from the prompt. Make sure the input voltage is driving the correct channel.

If a MAX181 is being used, the MUXOUT and ADCIN pins must either be externally shorted together or properly driven (see the MAX180/MAX181 data sheet).

Verify that the data-bus buffer (the 74HCT245) is being gated by the $\overline{\text{A2D-SEL}}$ and $\overline{\text{RD}}$ signals.

MAX180 Evaluation Kit

Timing Diagrams

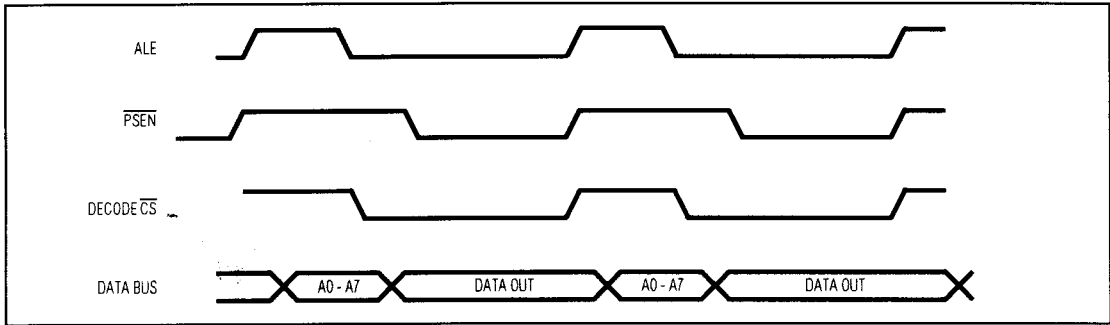

ROM Read Cycles

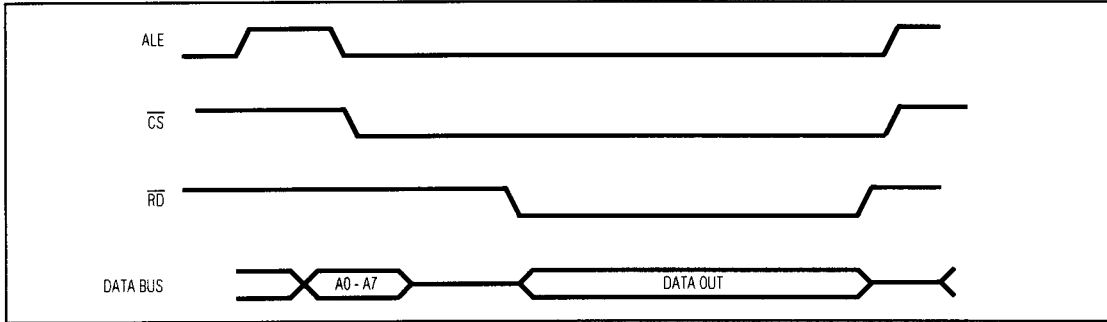

MAX180 Read Cycle

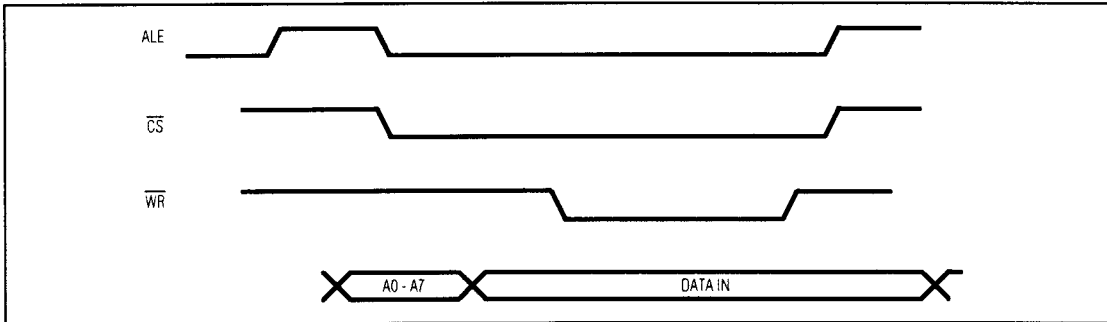

MAX180 Write Cycle

Consult the 80C32 data sheet for timing specifications.

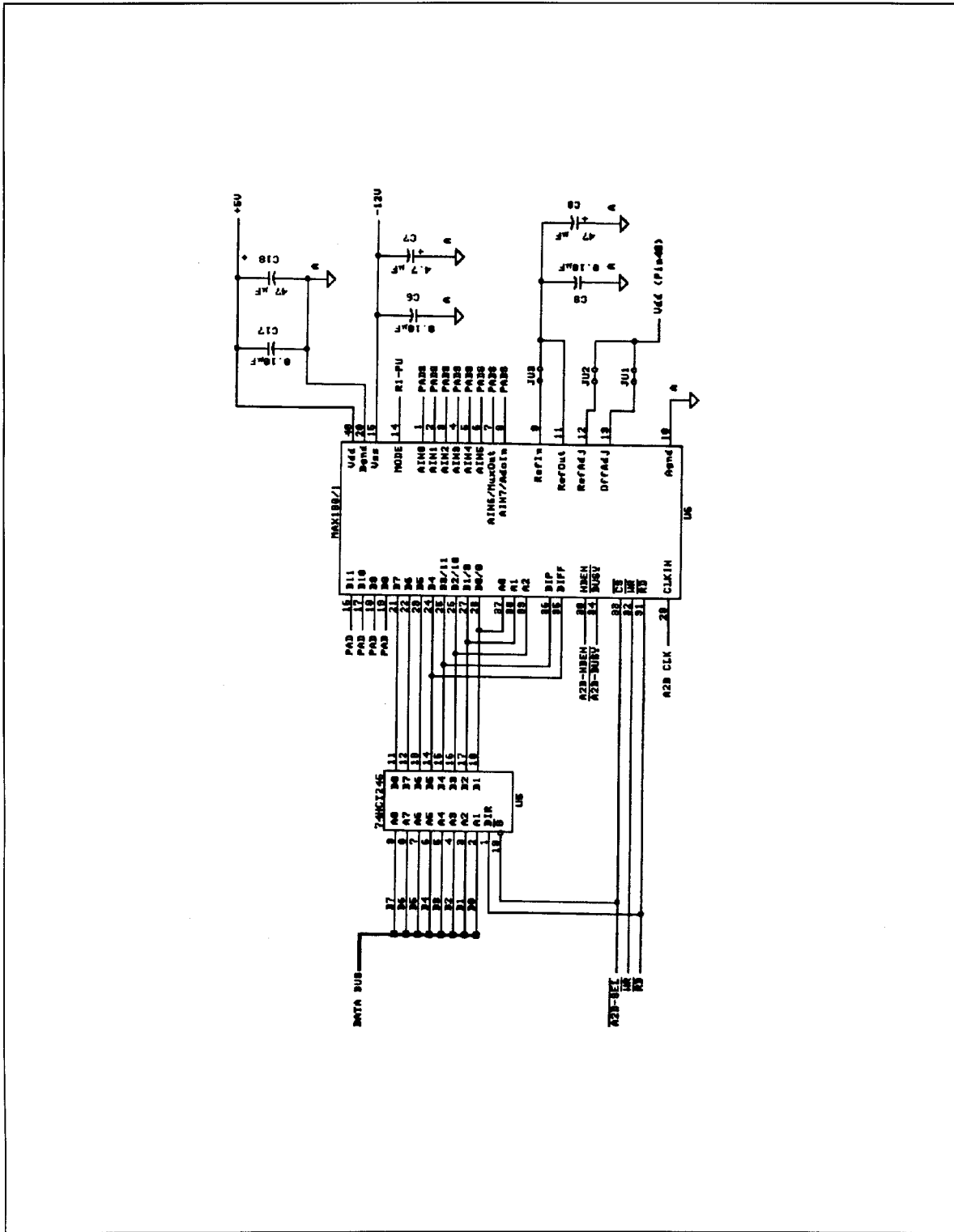

Figure 1a. MAX180 System Schematic

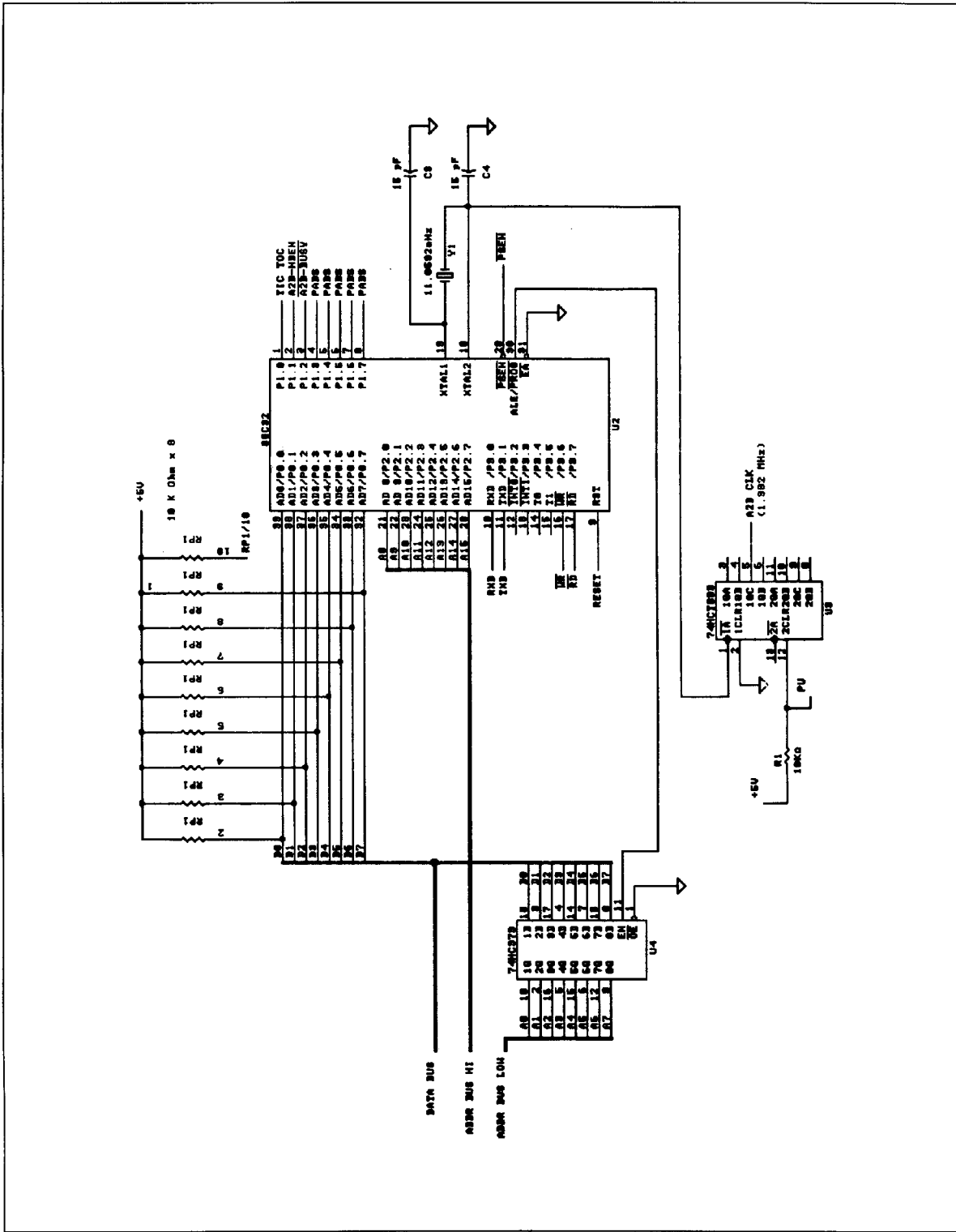

Figure 1b. MAX180 System Schematic

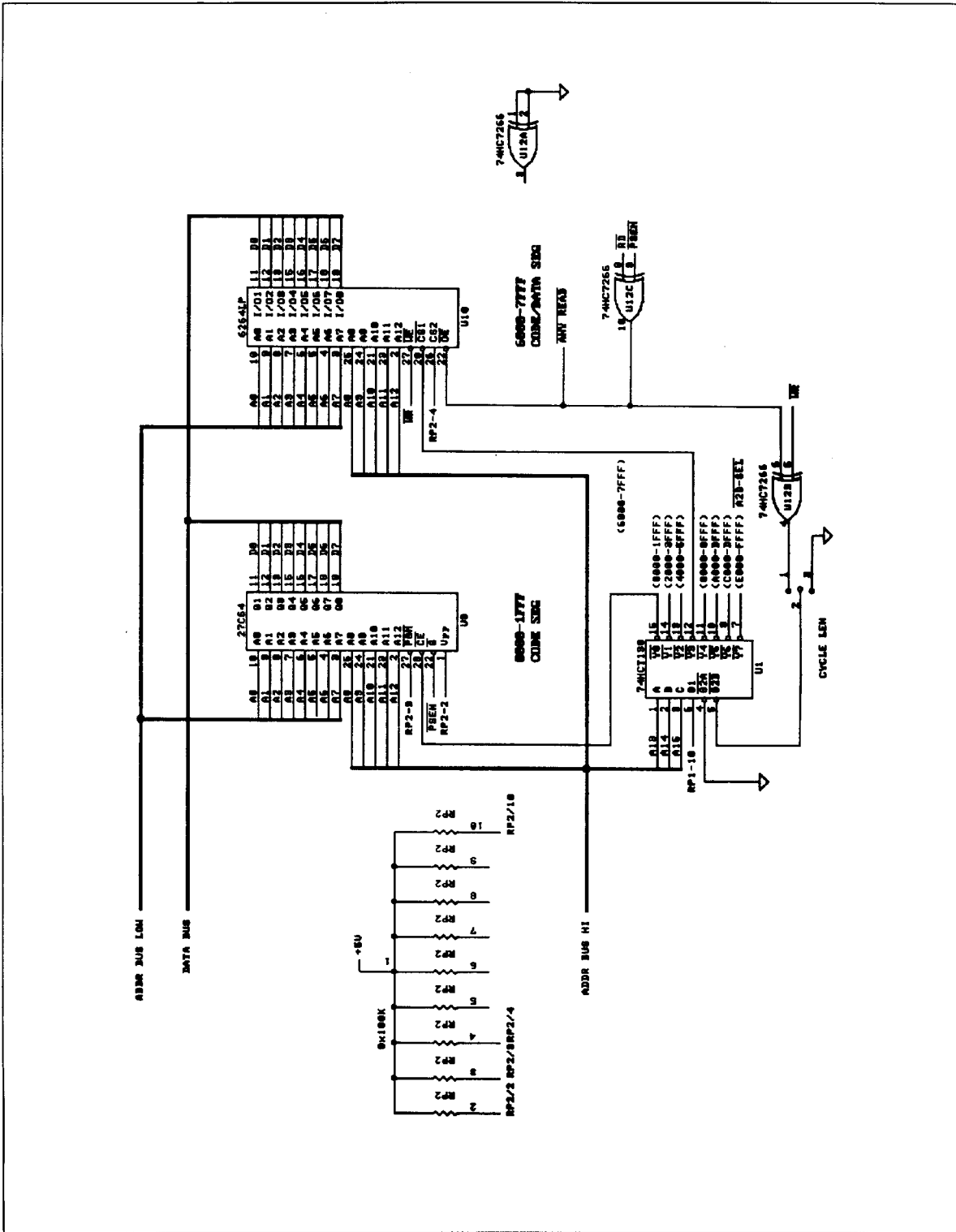

Figure 1c. MAX180 System Schematic

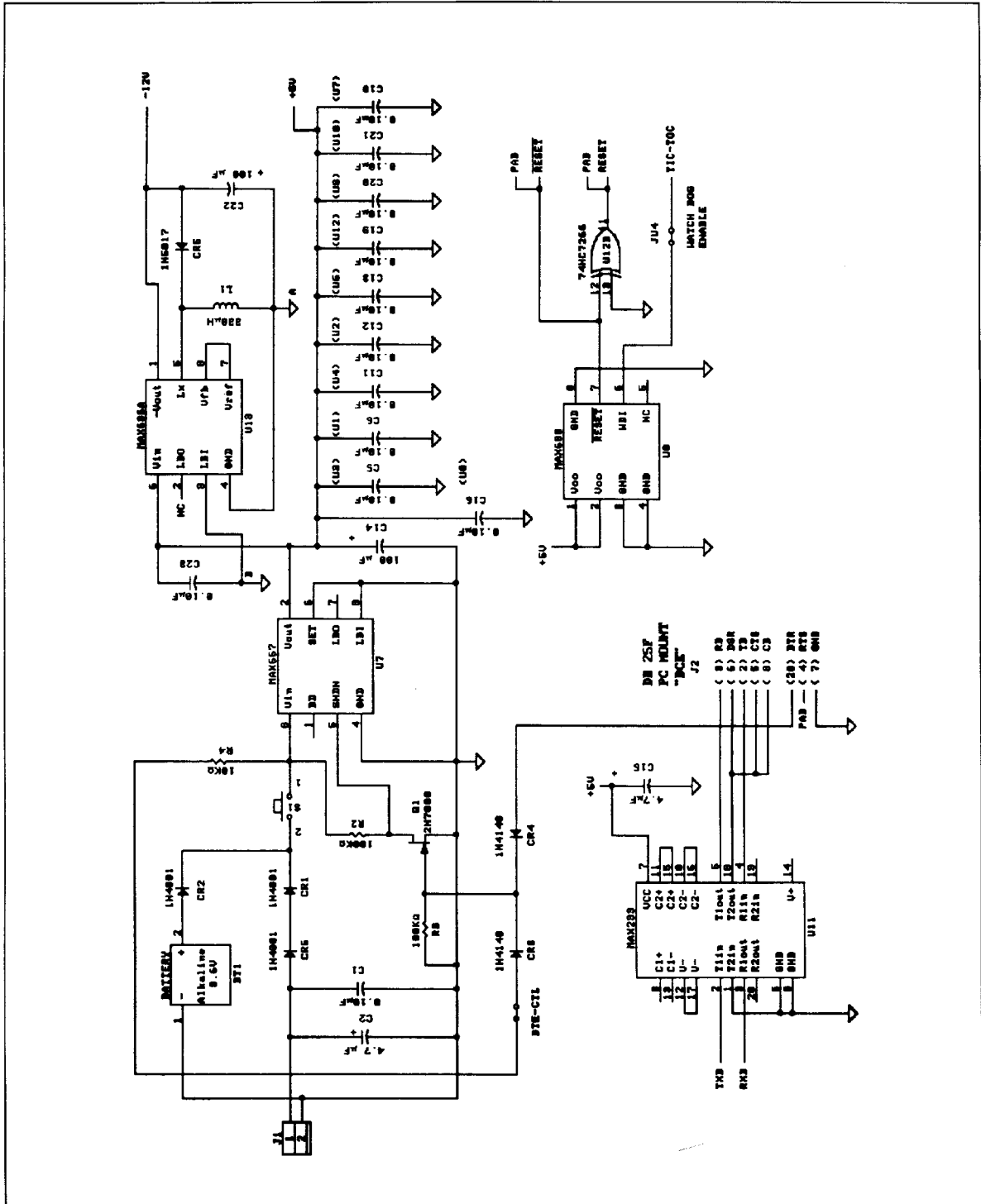

Figure 1d. MAX180 System Schematic

Maxim cannot assume responsibility for use of any circuitry other than circuitry entirely embodied in a Maxim product. No circuit patent licenses are implied. Maxim reserves the right to change the circuitry and specifications without notice at any time.