

ASSEMBLY NUMBER	PT NO.	DETAILS			DIMENSIONS					
		SHELL	COUPLING	CLAMP ASSY	C +.010 -.025	J	L +.030 -.010	N DIA +.000 -.031	Q DIA +.000 -.047	Z ±.035
71-148606	06E-6-	10-150906-63	10-123016-53	10-117930-63	.328	.353	.803	.440	.609	.525
71-148608	-8-	-83	-73	-83				.560	.734	
71-148610	-10-	-103	-93	-103				.685	.844	
71-148612	-12-	-123	-123	-123				.813	1.016	
71-148614	-14-	-143	-143	-143				.930	1.141	
71-148616	-16-	-163	-163	-163				1.057	1.266	
71-148618	-18-	-183	-183	-183				1.175	1.375	
71-148620	-20-	-203	-203	-203		.415	.928	1.301	1.516	.619
71-148622	-22-	-223	-223	-223			.928	1.430	1.641	
71-148624	-24-	-243	-243	-243			.990	1.555	1.761	
71-148625/50		NOT AVAILABLE								

ACCESSORIES
(NOT PART OF STANDARD ASSEMBLY)
SEE DRAWING
10-150000

REL NO.		REVISIONS		COMM REC	
CHG NO.	SYM	DESCRIPTION	DATE	APPROVAL	
32508-138					22553-46 22698-35
35513-24	5	WAS: REDRAWN, SIZE DD; REMOVED BACK KEY; REV N DIA COL	6-22-59		
36162-16	6	WAS TEST 9-3353-2 (PRO SPEC)	1-28-60		
36545-20	7	WAS 10-123016-63, 83-103 (COUPLING); REV WASHER DATA (-6,-8 8-10)	4-13-60		
37525-148	8	REM "BENDIX" FROM STAMPING	11-1-60		
	A	(CL II) SEE CHANGE NOTICE ECN: A4894	6/30/08	H. BROOKER	

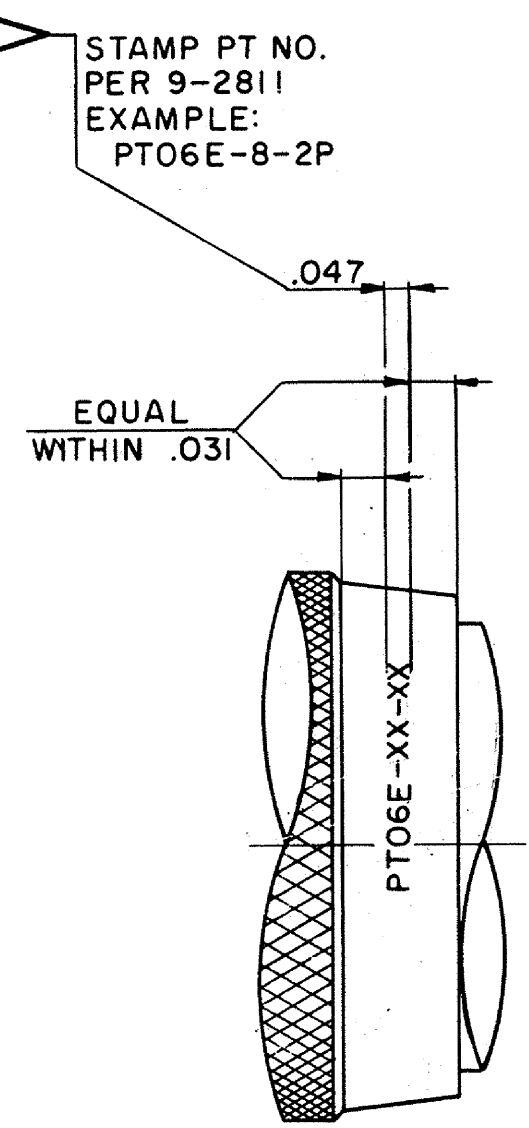
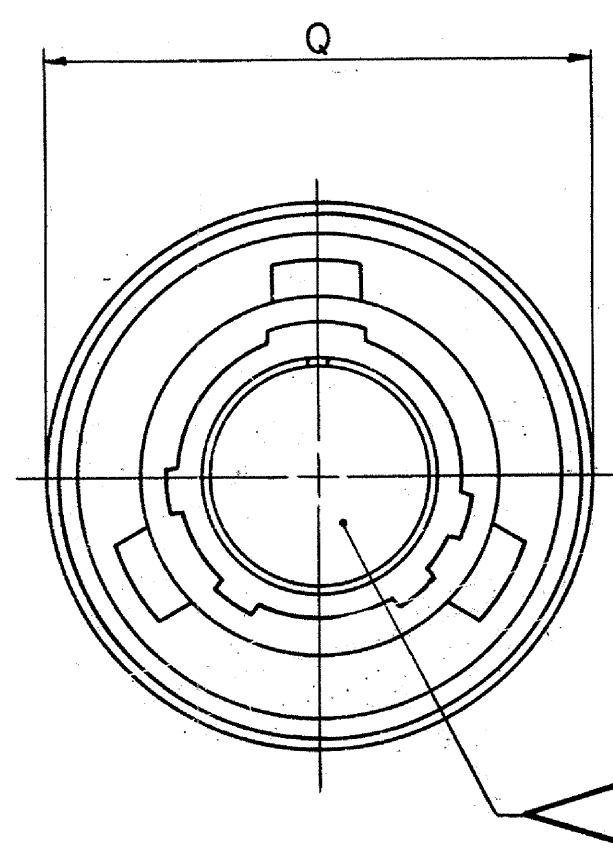
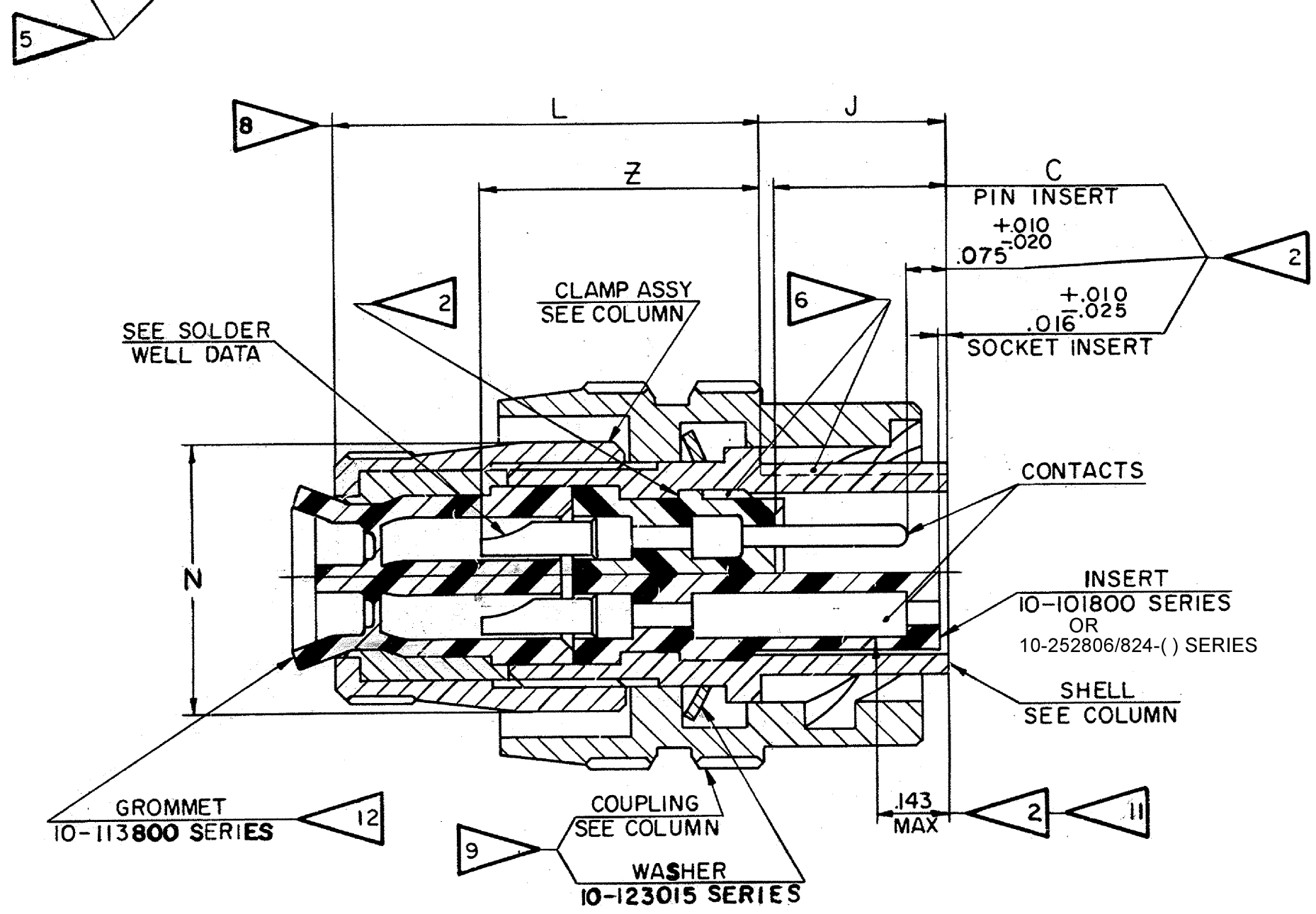

7. STAMP PT NO. PER 9-2811
EXAMPLE:
PT06E-8-2P

71-148606 THRU
71-148650

USE OF THIS DOCUMENT IS UNLIMITED. DOCUMENTS REFERENCED HEREON CONTAIN LIMITED RIGHTS DATA.

7. SEE WORK ORDER FOR PERMISSIBLE ADDITIONAL OR ALTERNATE STAMPING.
6. VERTICAL CENTERLINES OF INSERT ARRANGEMENT & THE MAIN SHELL POLARIZING KEY TO BE WITHIN .005 OF OF INDICATED ROTATION PER 9-2437-1.
5. TO COMPLETE ASSY NO. & PT NO., ADD APPLICABLE INSERT ARRANGEMENT SUFFIX TO BASE NUMBERS LISTED ABOVE PER 9-2437-1.
4. FOR COMPONENT PART NUMBERS OF DESIRED ARRANGEMENT, SEE APPLICABLE PARTS LIST.
3. MATES WITH RECEPTACLES 71-148006/50 & OTHERS.
2. DIMENSIONS MUST BE MAINTAINED WHEN INSERTS ARE PRESSED FIRMLY AGAINST INDICATED SHOULDER.
1. FOR CONTACT ARRANGEMENTS, SEE DRAWINGS L-15206-() THRU L-15250-().
- NOTES:
12. ALL UNUSED GROMMET HOLES TO BE FILLED WITH GROMMET SEALING ROD OR GROMMET SEALING PLUGS. SEE DRAWING 10-150000 (# 27 & # 28).
11. DISTANCE BETWEEN END OF SHELL & THE POINT AT WHICH A GAGE PIN, HAVING THE SAME BASIC DIAMETER AS THE MATING CONTACT & A SQUARE FACE, ENGAGES SOCKET CONTACT SPRING.
10. INSERTS & CONTACTS MUST NOT BE REMOVED.
9. COUPLING SLOTS & WASHER TO BE LUBRICATED PER 9-3502.
8. DIMENSION INDICATES FINAL INSTALLATION. FOR STORAGE & SHIPPING, SHELL & CLAMP ASSEMBLY MUST BE LOOSELY COUPLED.

SOLDER WELL DATA			
CONTACT SIZE	20	16	
WELL DIA	.046 ^{+.004} _{-.000}	.078 ^{+.004} _{-.002}	
WELL DEPTH	.125 ^{+.031} _{-.000}	.188	

PROCESS SPEC TEST 9-3980-2 ASSY 9-3443-2, 9-2437-1 9-3502, 9-2811		ABBREVIATIONS & SYMBOLS (MNC) MAXIMUM MATERIAL CONDITION (TP) TRUE POSITION		TITLE:	
UNLESS OTHERWISE SPECIFIED 1. TOLERANCES: LINEAR .000, .010, .005, .02, 0.1 ANGULAR .2 2. ALL LOCATION TOLERANCES APPLY AT MAXIMUM MATERIAL CONDITION (MMC) 3. RADIUS FILLETS & BREAK EDGES .005, 0.1 4. CONCENTRICITY .015 TIR REGARDLESS OF SIZE FOR DRAWING INTERPRETATION SEE SPEC 9-3800		ORIG ENG JOB NO. 54G		DATE: 1-11-57	
MATERIAL SPEC		HEAT TREAT SPEC		FINISH SPEC	
DRAWN: VIMISLIK		CHECKED: BALANTIC P		DATE: 7/6/59	
APPR: [Signature]		DATE: 7/6/59		SCALE: NONE	
LIST OF MATERIAL		DESCRIPTION		APPLICATION	
ITEM	REQD	PART NO.	DESCRIPTION	UNIT WT	NEXT ASSY
			CONNECTOR, ELECTRICAL PLUG, TYPE PTE (MNC), OLIVE DRAB		
				SCINTILLA DIVISION BENDIX AVIATION CORPORATION SIDNEY, N. Y., U.S.A.	
				71-148606 THRU 71-148650	
				DRAWING SIZE: C TAB.	