

LOC		DIST		P		F		ZONE		LTR		REVISIONS			
DF	H0											DESCRIPTION	DATE	APPD	
												A	REDRAWN PER DF-6290 TA	10-12-92	JW
												B	REV PER 0600-1174-93 TA	12-6-93	JW
												C	REV PER 0600-4864-95 CT	1-96	JW
												D	REV PER 0600-5129-96 TA	4-15-96	DW

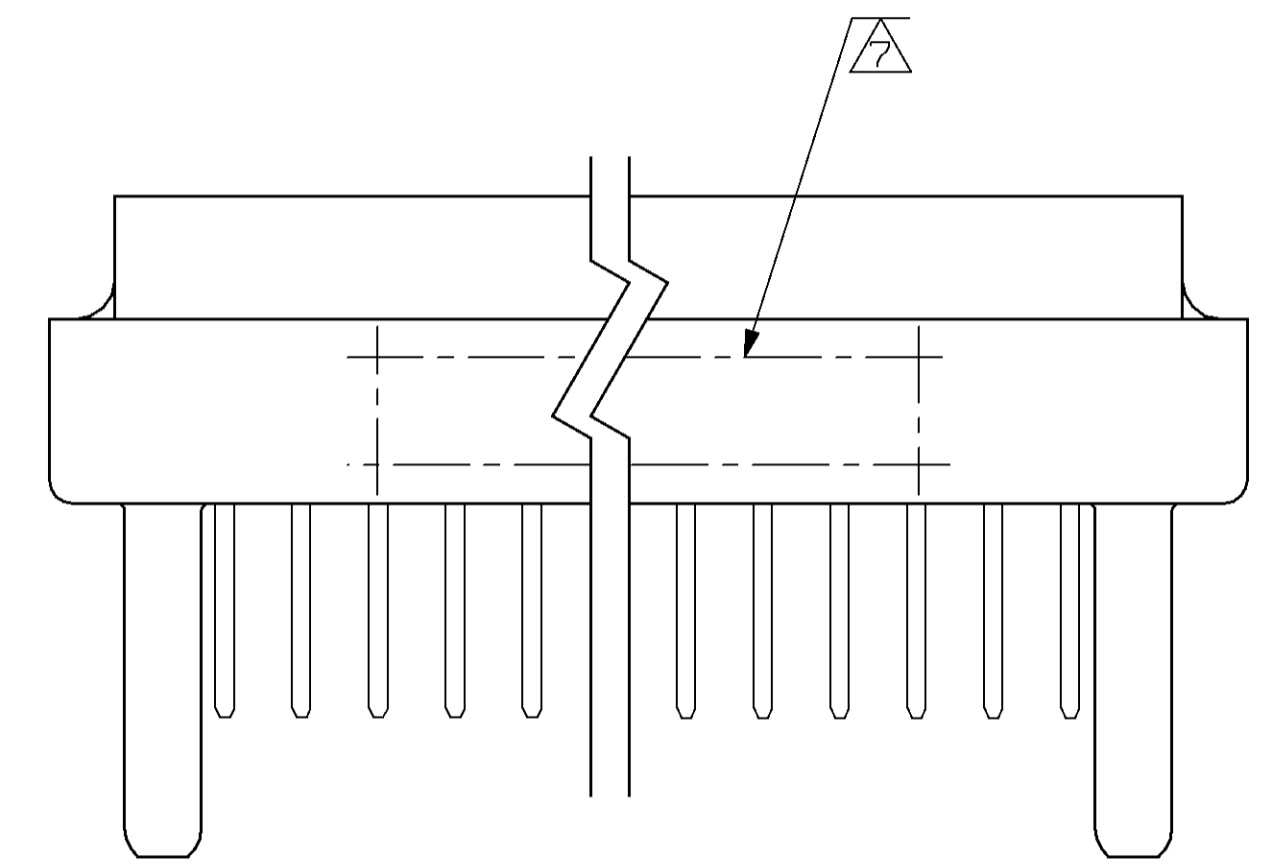

VIEW Z-Z

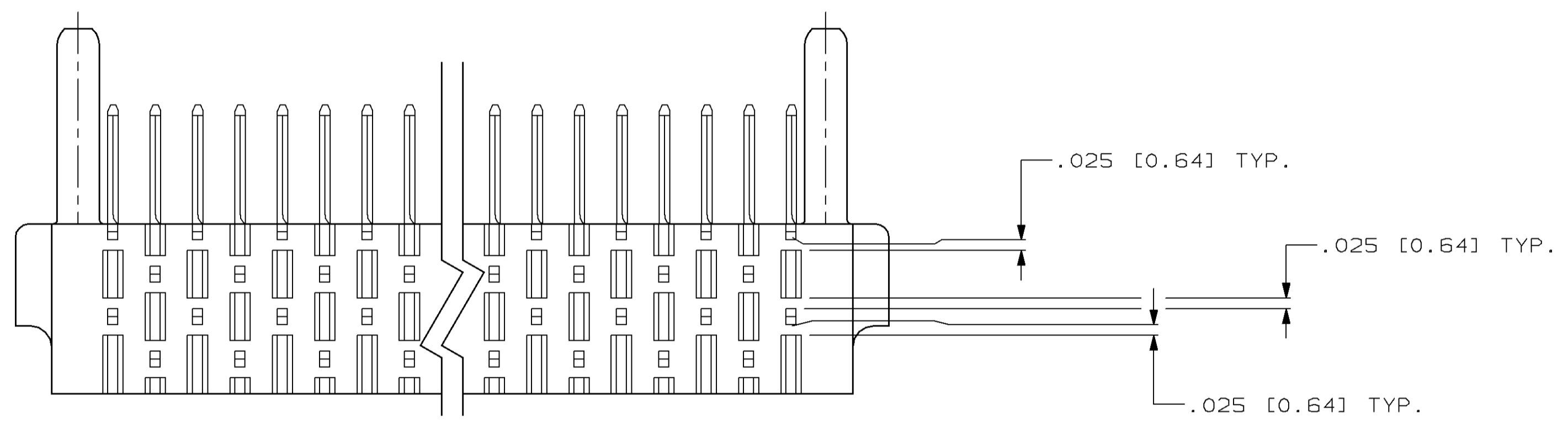
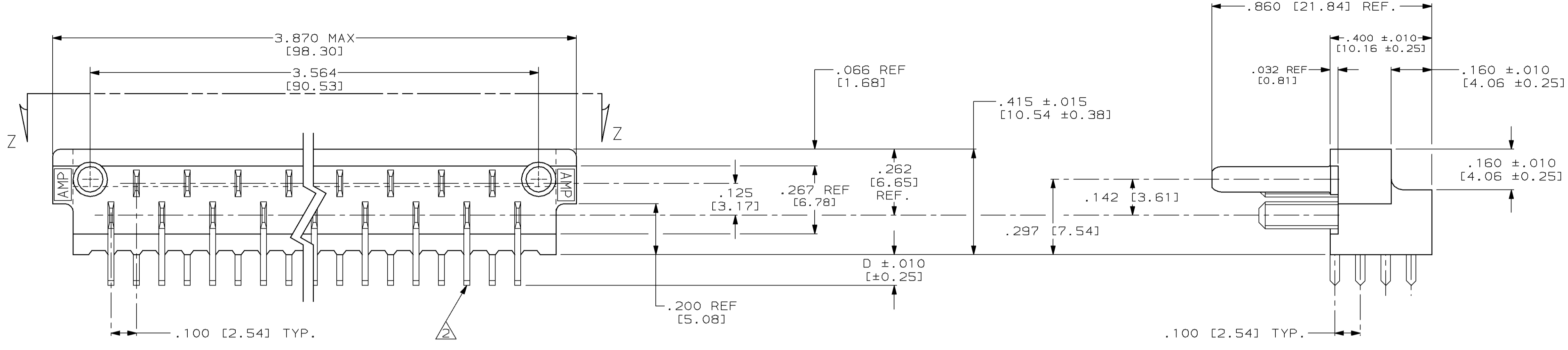
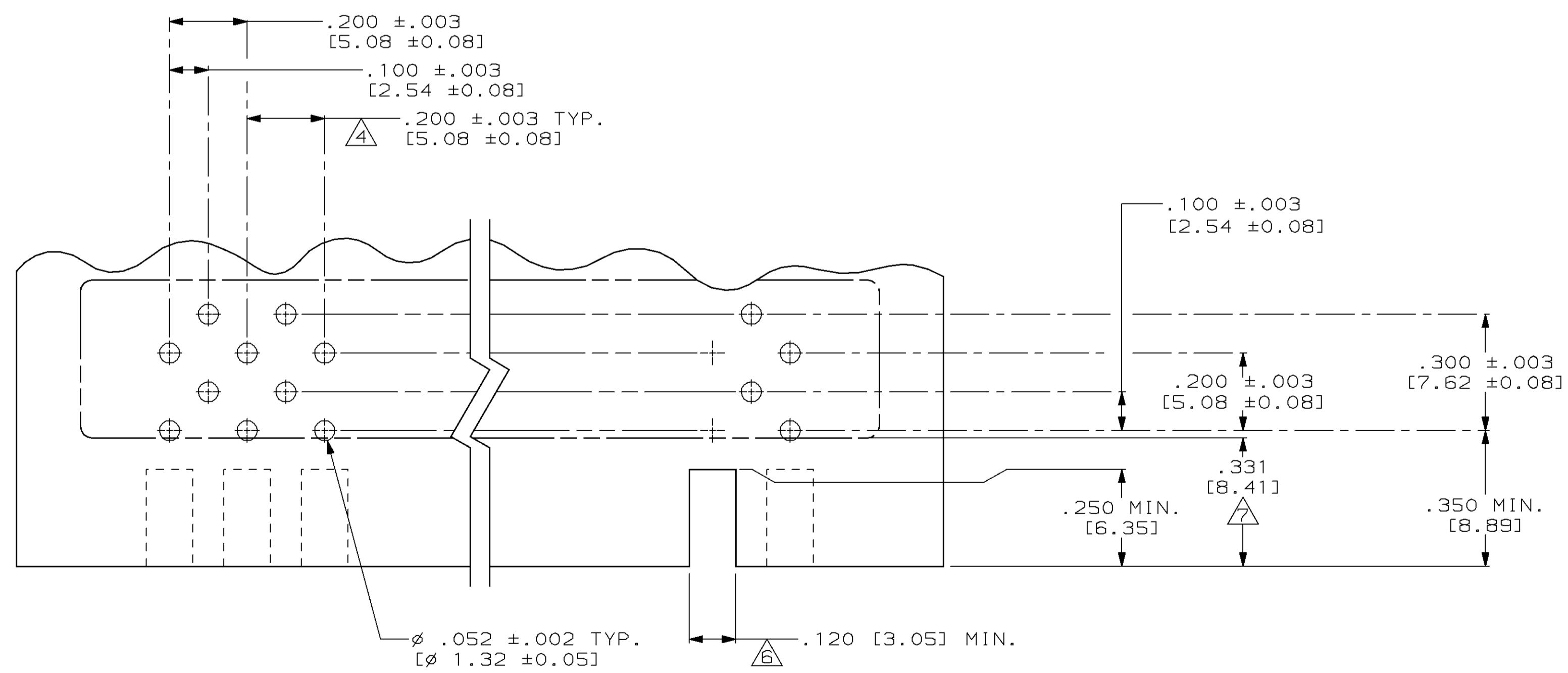

RECOMMENDED P.C. BOARD LAYOUT

- △ CONTACT FINISH: .000015 THK. GOLD IN THE CONTACT AREA. GOLD FLASH ON THE REMAINDER, ALL OVER .000050 THK. NICKEL.
- △ POST TO BE SOLDER DIPPED. CONN. MUST MEET REQUIREMENTS OF AMP SPEC 109-11-1.
- △ CONTACT MATERIAL: GILDING METAL.
- △ TOLERANCE NON CUMULATIVE.
- △ TAB-HOUSING MATERIAL: FLAME RETARDANT THERMOSET DIALLYL PHTHALATE. COLOR: GREEN
- △ CUT OUT FOR KEYING BOSS, LOCATED WHERE REQD. (OPTIONAL)
- △ AMP P/N & DATE CODE, MARKED WITH .062 ±.015 HIGH CHARACTERS, THIS APPROXIMATE AREA.

DO NOT SCALE PRINT. UNLESS SPECIFIED DIMENSIONS IN INCHES [mm] TOLERANCES ON:		DR T. ALEXANDER 10-9-92		PART NO	
2 PLC DEC ± -		CHK J. WARNER 10-12-92		AMP Incorporated Harrisburg, PA 17105-3608	
3 PLC DEC ±.005 [0.13]		APPD J. WARNER 10-12-92		NAME	
ANGLES ± -		APPD T. ALEXANDER 10-12-92		ASSEMBLY, AMP BLADE, TAB HOUSING	
MATERIAL		PRODUCT SPEC		SIZE	
△ 3 △ 5		-		D 00779	
FINISH		APPLICATION SPEC		CAGE CODE	
-		-		00779	
WEIGHT		SCALE		DRAWING NO	
-		4:1		448274	
				SHEET 1 OF 1	