

1 2 3 4

A

B

C

D

E

F

A

B

C

D

E

F

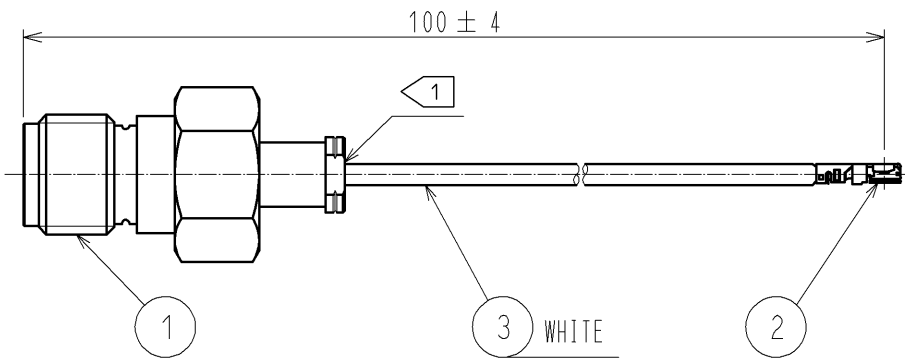

NOTE 1 Do not apply any excessive stress to the cable assembly position.
 2 The drawing shows mated connector height only.

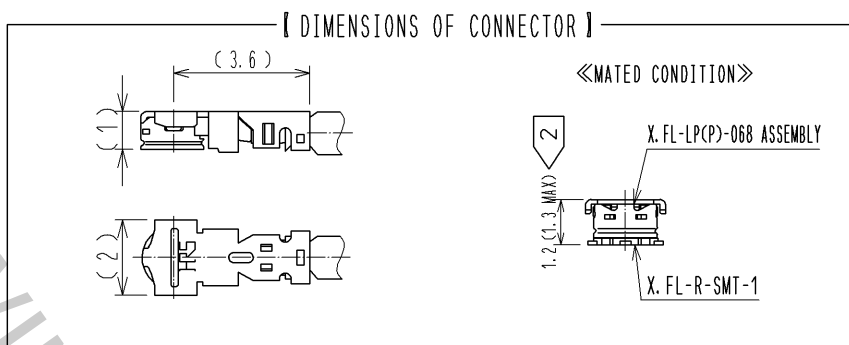

【 PRECAUTIONS FOR HANDLING 】

◆ Connector insertion and extraction
 a. Insert the connector as perpendicularly to the mating surface as possible with aligning the mating axes of both connectors by specialised insertion JIG.
 Part No. : W.FL-LP-IN(CL331-0323-2) or X.FL-LP-IN.OUT1(CL331-0715-2)
 Do not excessively slant the connectors when inserting.

b. connector shall be extracted by specialised extraction JIG.
 Part No. : X.FL-LP-IN.OUT1(CL331-0715-2)
 Never hold the cable when extracting the cable because it damages the connector.

◆ Allowable loads on the cable after the connectors are mated.
 The right figures show the maximum allowable loads on the cable.
 Do not apply loads exceeding these values to the cable.

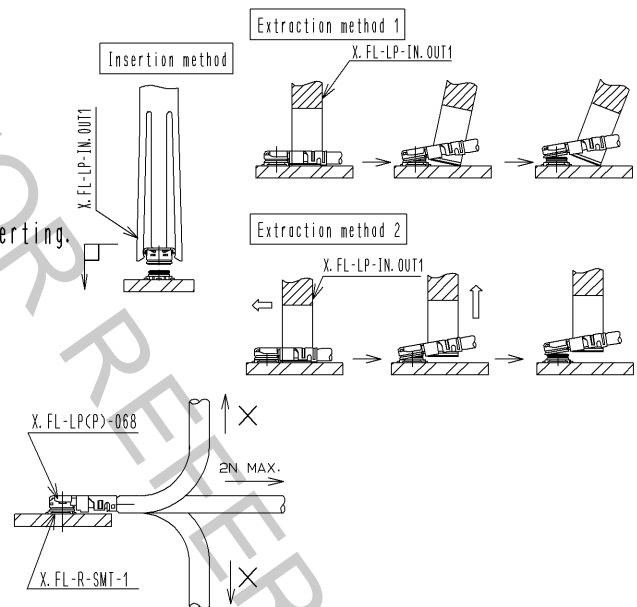

RoHS COMPLIANT

2	X.FL-LP(P)-068	CL331-0714-0-00			
1	HRM-200-066JBN(40)	CL323-0793-1-40	3	FWS5064(WHITE)	KURABE INDUSTRIAL CO., LTD.
NO.	PART NO.	CODE NO.	NO.	PART NO.	MANUFACTURER

UNITS mm		SCALE FREE	COUNT 	DESCRIPTION OF REVISIONS	DESIGNED	CHECKED	DATE
APPROVED : KY. SHIMIZU 14. 11. 17 CHECKED : TO. KATAYAMA 14. 11. 17 DESIGNED : YI. FUNADA 14. 11. 14 DRAWN : YI. FUNADA 14. 11. 14				DRAWING NO. EDC4-361456-01 PART NO. HRMJ-X.FL-068K3TS-A-100RS CODE NO. CL321-6605-0-01			