

PROPER USE GUIDELINES

Cumulative Trauma Disorders can result from the prolonged use of manually powered hand tools. AMP hand tools are intended for occasional use and low volume applications. AMP offers a wide selection of powered application equipment for extended-use, production operations.

CONNECTOR TYPES	CONNECTOR-SPECIFIC KITS
Standard and Novo Receptacle	768341-1 (408-9831)†
Card Edge	768346-1 (408-9832)†
HDF Low Profile	768349-1 (408-9833)†
I/O Pin	768344-1 (408-9836)
DIP	768347-1 (408-9837)
Stackable Receptacle	768342-1 (408-9841)
CHAMP* Latch Low-Profile	768351-1 (408-9839)
50-Position HDF	768350-1 (408-9834)
EUROLATCH*	768352-1 (408-9840)
Pre-Assembled Paddleboard	768348-1 (408-9838)
Low Profile Receptacle	768792-1 (408-9835)

† Provided with AMP-LATCH* Hand Tool Kit 768340-1

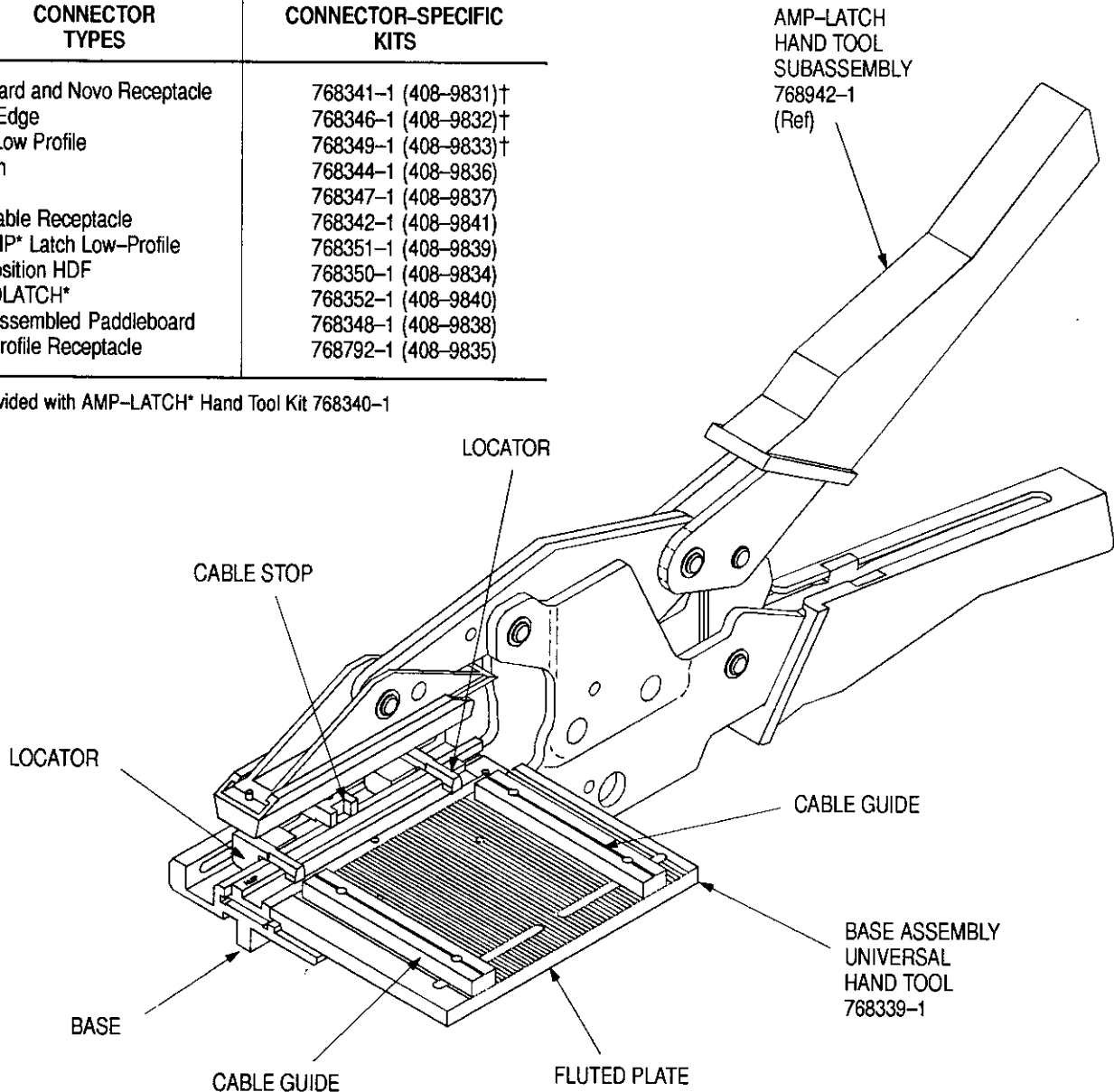

Figure 1

cad

1. INTRODUCTION

These instructions cover installation, setup, and termination procedures for AMP Base Assembly Universal Hand Tool 768339-1. The tooling assembly is used with AMP-LATCH Hand Tool Subassembly

768942-1 and connector-specific kits to terminate AMP-LATCH and CHAMP Latch Low-Profile Connectors having 1.27 mm [.050 in.] centerline spacing. The Base Assembly Universal Hand Tool and hand tool subassembly are also parts of AMP-LATCH Hand Tool Kit 768340-1. See Figure 1.

NOTE

Dimensions are in metric units [with U.S. customary units in brackets].

2. DESCRIPTION (Figure 1)

The Base Assembly Universal Hand Tool consists of a base, a fluted plate, two cable guides, a cable stop, and two locators. The base attaches to the lower jaw of the hand tool subassembly. The fluted plate provides proper seating and alignment of the ribbon cable. The cable guides aid in positioning the ribbon cable with the connector assembly. The cable stop provides proper positioning of the ribbon cable for flush terminations. The locators provide proper positioning of the connector assembly with the ribbon cable.

3. CABLE REQUIREMENTS (Figure 2)

When used with the hand tool subassembly and appropriate connector-specific kit, the tooling assembly will terminate ribbon cable with 26 AWG solid or stranded conductors, 28 AWG solid or stranded conductors, or 30 AWG solid conductors to the connectors listed in Figure 1. Recommended cable dimensions are shown in Figure 2.

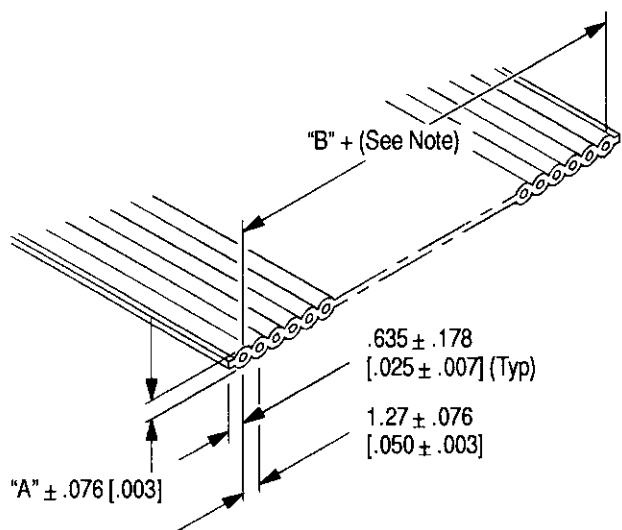

NOTE

ACCUMULATIVE TOLERANCE FOR CABLE CONDUCTORS 1 THROUGH 34 IS + .254 [.010] AND THROUGH 60 IS + .38 [.015].

CONDUCTOR		DIMENSION	
SIZE (AWG)	TYPE	"A"	"B"
26	Stranded or Solid	0.889 mm [.035 IN.]	1.27 mm [.050 IN.] X (Total No. of Conductors Minus One)
28	Stranded or Solid		
30	Solid		

Figure 2

cad 9831

NOTE

The cable end must be cut squarely with the conductors; otherwise an improper termination will result. AMP suggests the use of a guillotine-type cable cutter such as the Carpenter Model 95, which can be purchased from:

Carpenter Manufacturing Co., Inc.
Fairgrounds Drive
Manlius NY 13207

4. INSTALLATION

1. Attach base to hand tool subassembly and secure.
2. Slide the lower insert from connector-specific kit into slot of fluted plate and secure with two setscrews. See Figure 3.
3. Slide upper tool from connector-specific kit into upper tooling mount.

5. SETUP

1. Select appropriate cable and connector assembly for the connector-specific kit.
2. Remove cable stop.

NOTE

The hand tool subassembly may be mounted on a bench by using the bench mount assembly (AMP Part Number 543264-1). Refer to 408-9828.

3. Place the cable in the flutes of the fluted plate and center with the cable stop slot.

NOTE

Cable conductors must stay in the same flutes for the entire length of the fluted plate.

4. Seat the cable guides along each side of the cable and lock into position.

NOTE

Cable guide key should be in the same flute for its entire length.

5. Remove cable from fluted plate.
6. Place the connector assembly, cover down, into the lower insert and place the cable between the cable guides and into the flutes of the fluted plate.
7. Slide the cable into the connector assembly until the cable is flush with the far side of the connector assembly cover.
8. Adjust connector assembly until cable is seated in all the cover flutes.
9. Seat the locators against the connector assembly and secure in position.

NOTE

Depending upon the number of contact positions in the connector assembly, the locators should be oriented as shown in Figure 3 to accommodate the length of the connector assembly.

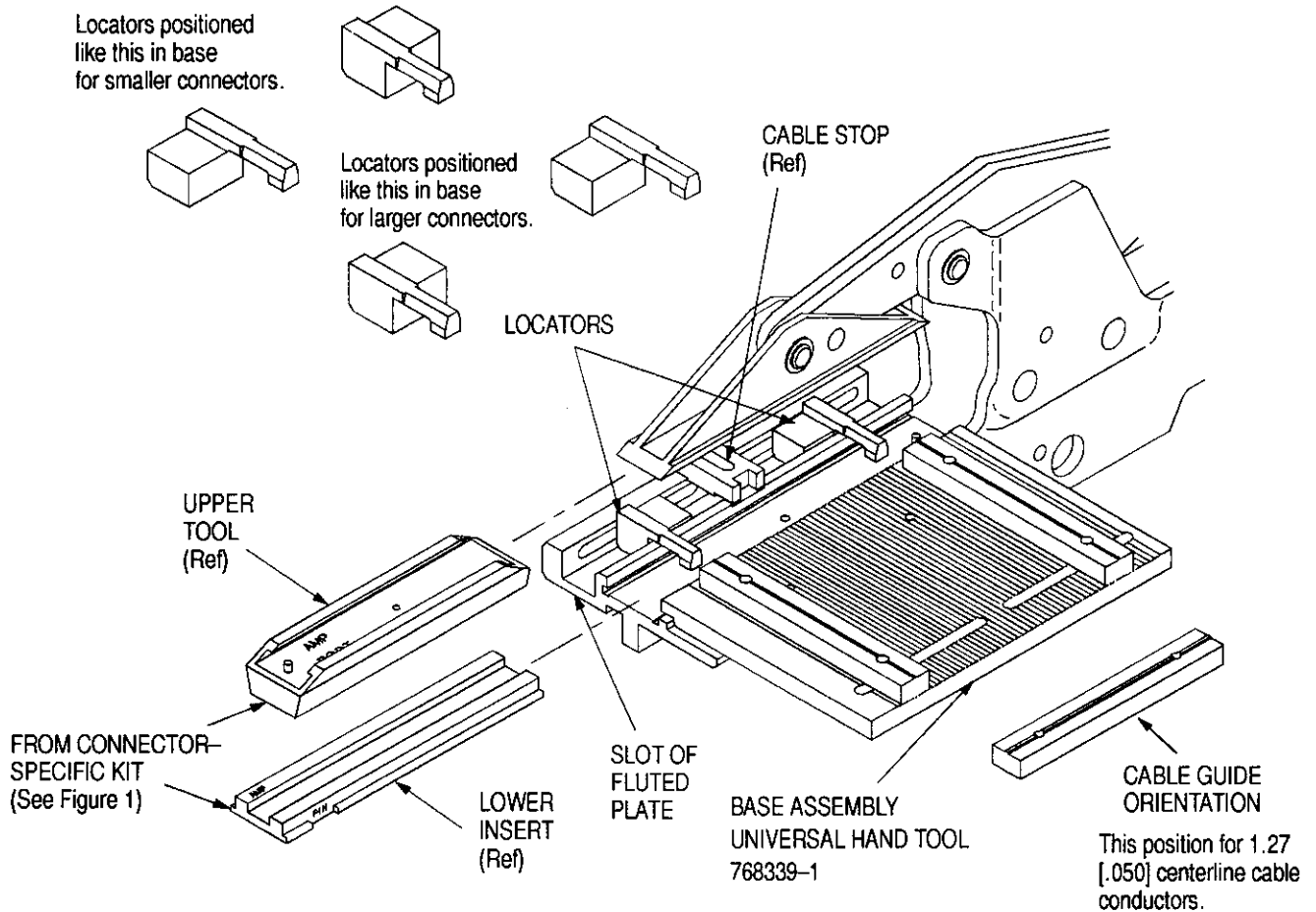

Figure 3

oad

NOTE

Cable conductors must be in the same flutes for the entire length of the fluted plate and the cable conductors should fill in all the flutes of the connector assembly cover.

10. Arrange the cable stop as follows:
 - a. For flush terminations, adjust the cable stop to the desired position.
 - b. For daisy-chain (feed-through) terminations, remove the cable stop.

6. TERMINATING CONNECTORS

Each connector type has a connector-specific kit for use with the Base Assembly Universal Hand Tool. It is necessary for the operator to read and understand the instructions packaged with the connector-specific kit. Each connector-specific kit has distinctive components for terminating connectors, which must be mounted on the hand tool subassembly. Refer to Figure 1 for a list of connector types and their connector-specific kits.

1. Position the connector (cover down) into the lower insert of the tool, and between the locators.

NOTE

In some instances the tool opening restricts the connector assembly from gaining entrance into the lower insert when using two locators. The front locator may be removed to gain entry into the lower insert, or the upper tool may be removed and replaced for each termination.

2. Place the cable stop against the connector for flush termination, or remove the cable stop for daisy-chain applications.
3. Position the ribbon cable between the cable guides and press down to seat the conductors into the flutes of the fluted plate.
4. Slide the ribbon cable through the connector and against the cable stop. For daisy chain terminations, slide the cable to the appropriate position.
5. Close the tool handles until the ratchet releases, and allow them to open fully before removing the terminated connector.

7. MAINTENANCE/INSPECTION

A. Maintenance

Base Assembly Universal Hand Tool 768339-1 requires little maintenance other than to ensure that all required components are in place and secured (if applicable). Use a clean, soft, lint-free cloth or a clean, soft brush to remove dust, moisture, and any contaminants from the assembly. Do NOT use any objects or materials (such as solvents) that could damage the tooling.

B. Inspection

AMP recommends that the tooling assembly be inspected immediately upon its arrival at your facility and at regularly scheduled intervals thereafter to ensure that it has not become damaged during shipping and by subsequent use. Inspection should ensure that all components are in place and secured

(if applicable). If any components require replacement, refer to Figure 4 for customer-replaceable parts and order replacements by part number.

8. PARTS REPLACEMENT

Figure 4 provides tool dimensions and customer-replaceable parts. For information regarding tooling beyond the scope of this document call the AMP Tooling Assistance Center number on the first page.

Additional tools and replacement parts may be ordered through your AMP representative, or call 1-800-526-5142, or send a facsimile of your purchase order to 1-717-986-7605, or write to:

CUSTOMER SERVICE (38-35)
 AMP INCORPORATED
 P.O. BOX 3608
 HARRISBURG, PA 17105-3608

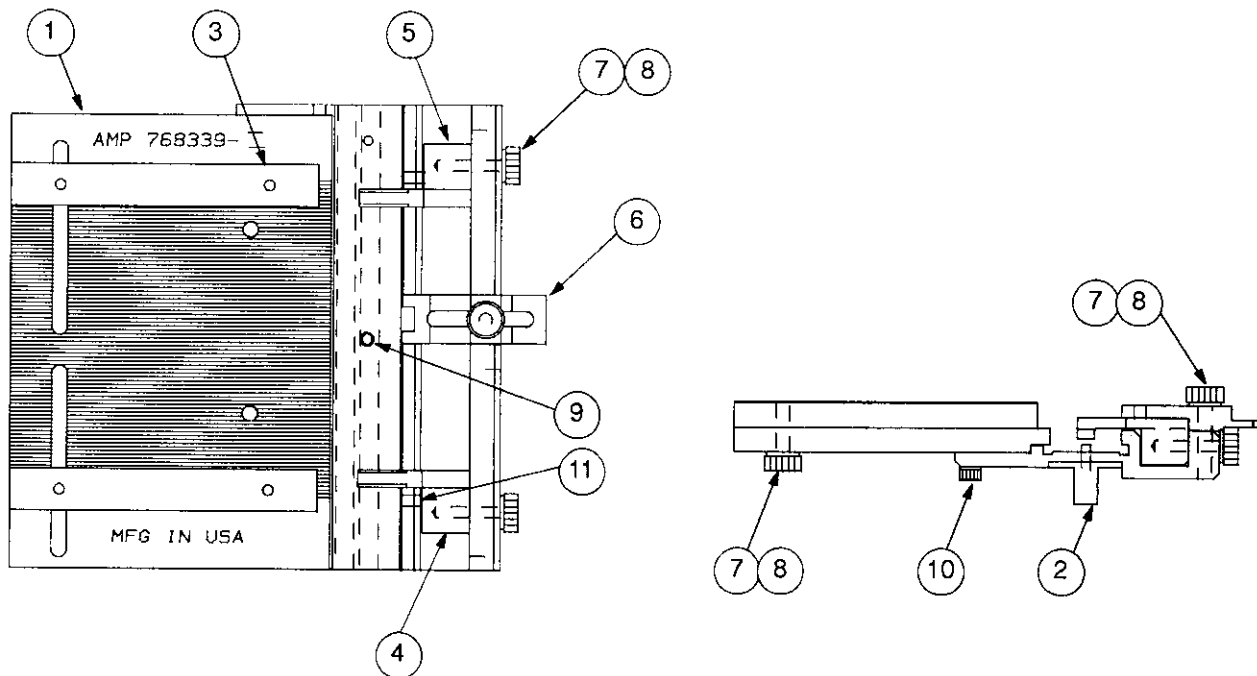

CUSTOMER-REPLACEABLE PARTS

ITEM	PART NUMBER	DESCRIPTION	QTY	ITEM	PART NUMBER	DESCRIPTION	QTY
1	768604-1	PLATE, Fluted	1	7	27708-2	KNOB, Thumbscrew, No. 6	5
2	768611-1	BASE, Machined	1	8	2-21000-0	SCREW, Skt Hd 6-32 x .50 L	5
3	768597-1	GUIDE, Cable	2	9	23057-4	PLUNGER, Ball, SST	1
4	768607-1	LOCATOR, Front	1	10	1-21000-9	SCREW, Skt Hd 6-32 x .38 L	2
5	768608-1	LOCATOR, Rear	1	11	2-21006-7	SCREW, Set 6-32 x .25 L	2
6	768613-1	STOP, Cable	1				

Figure 4

cad