

Description

The ZXSC100 series is designed for DC-DC applications where step-up voltage conversion from very low input voltages is required. These applications mainly operate from single nickel cadmium or nickel metal hydride battery cells.

The circuit can start up under full load with regulation maintained down to an input voltage of only 0.926 volts. The solution configuration ensures optimum efficiency over a wide range of load currents. Several circuit configurations are possible with loads up to 2W. The step up output voltage is easily programmed with external resistors. With its non-synchronous architecture an output voltage down to the input voltage level can be achieved. For best performance the ZXSC100 quiescent current is a small 150µA ensuring minimum battery drain in no load conditions.

The IC and discrete combination offers the ultimate cost vs. performance solution for single cell DC-DC conversion.

Pin Assignments

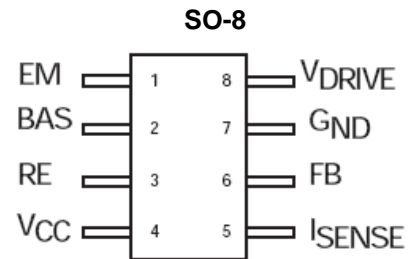

Features

- Efficiency maintained over a wide range of input voltages and load currents 82% efficiency @ $V_{BATT} = 1V$
- Startup under full load
- Minimum operating input voltage $V_{BATT} = 0.926V$
- Adjustable output voltage down to V_{BATT}
- Quiescent current typically 150µA referred to input voltage
- SO-8 package in “Green” Molding Compound (No Br, Sb) with lead Free Finish/RoHS Compliant (Note 1)

Notes: 1. EU Directive 2002/95/EC (RoHS). All applicable RoHS exemptions applied. Please visit our website at: http://www.diodes.com/products/lead_free.html

Applications

- Cordless telephones
- MP3 players
- PDA
- Pagers
- Battery backup supplies
- Electronic toothbrush
- GPS receivers
- Digital camera
- Palmtop computers
- Hand held instruments
- Portable medical equipment
- Solar powered equipment

Typical Application Circuit

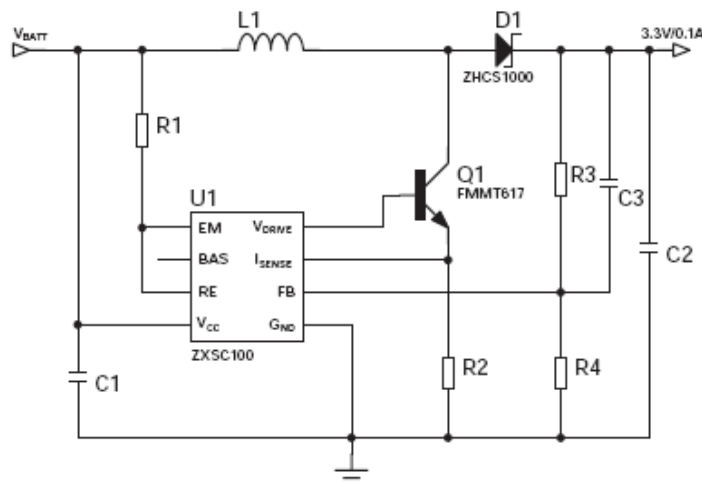

Pin Descriptions

Pin No.	Name	Description
1	EM	Emitter of internal drive transistor. Connect to RE in lower power applications. Must be unconnected in higher power applications.
2	BAS	Only used if increased drive current to the main external NPN switching transistor is required. (See Note 2).
3	RE	Drive current sense input. Internal threshold voltage set 25mV below V_{CC} . Connected external sense resistor. (Note 2)
4	V_{CC}	Supply voltage, generally NiMH, NiCd single cell.
5	I_{SENSE}	Inductor current sense input. Internal threshold voltage set to 25mV. Connect external sense resistor.
6	FB	Feedback sense. Internal threshold set to 730mV. Connect external resistive divider to output voltage.
7	GND	Ground
8	V_{DRIVE}	Drive output for external switching transistor. Connect to base of external bipolar transistor. For increased drive current see Note 2

Note: 2. In higher load current applications an additional PNP can be used to increase the drive current of the main external NPN switching transistor. The PNP base should be connected to BAS pin, its emitter to the RE pin and its collector connected to V_{DRIVE} pin.

Functional Block Diagram

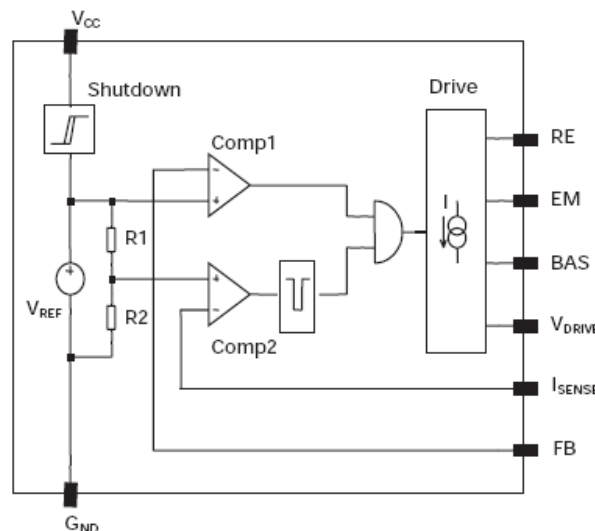

Absolute Maximum Ratings

Description	Rating	Unit
Supply Voltage	0.3 to 3.5	V
Maximum Voltage Other Pins	0.3 to $V_{CC} + 0.3$	V
Power Dissipation (25°C) SO-8	780	mW
Operating Temperature	0 to 70	°C
Storage Temperature	-55 to +150	°C
Junction Temperature	150	°C



Operating Conditions

Symbol	Parameter	Min	Typ.	Max	Unit
F _{OSC}	Recommended operating frequency (Note 3)			200	kHz

Note: 3. Operating frequency is application circuit dependent. See application section.

Electrical Characteristics (T_A = 25°C, V_{CC} = 1.2V; unless otherwise specified)

Symbol	Parameter	Conditions	Min	Typ	Max	Units
I _{CC}	Quiescent current	Not switching		150	200	μA
I _{DRIVE}	Base drive current	V _{RE} = V _{CC}	5		10	mA
V _{DRIVE}	V _{DRIVE} o/p voltage	V _{RE} = V _{CC} , I _{DRIVE} = 5mA	V _{CC} - 0.17			V
V _{FB}	Feedback voltage		708	730	752	mV
V _{ISENSE}	Output current reference voltage		12	17.5	24	mV
T _{CVISENSE}	I _{SENSE} voltage temp co.			0.4		%/°C
V _{DREF}	Drive current refernce voltage	Measured with respect to V _{CC}	20	30	40	mV
T _{CVDREF}	V _{DREF} temp co.			1		%/°C
V _{CC(SRT)}	Startup voltage	Any output load	1.01	1.06	1.1	V
V _{CC(MIN)}	Minimum operating input voltage		0.926	0.98	1	V
V _{CC(HYS)}	Supply start up to shutdown hysteresis			80		mV
I _{FB}	Feedback input current			100	200	nA
I _{SENSE}	I _{SENSE} input current	V _{ISENSE} = 0V	3	4	5.5	μA
V _{O(MIN)}	Minimum output voltage		V _{CC}			V
V _{O(MAX)}	Maximum output voltage	FMMT617 as pass element (Note 4)			20	V
T _{OFF}	Discharge pulse width		1.7	3		μs

Note: 4. Depends on breakdown voltage of pass device. See FMMT617 datasheet

Typical Characteristics

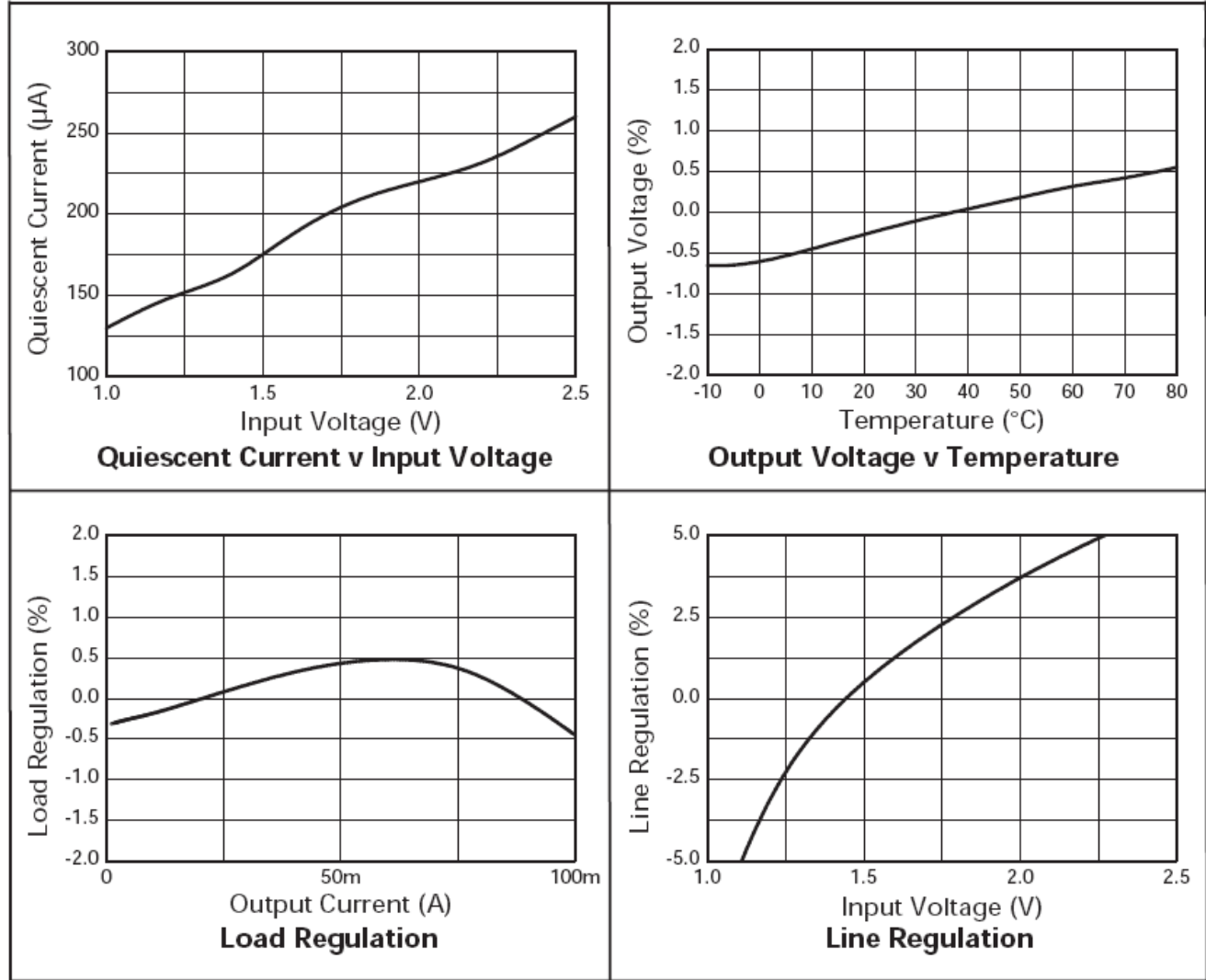



Device Description

The ZXSC100 is non-synchronous PFM, DC-DC controller IC which, when combined with a high performance external transistor, enables the production of a high efficiency boost converter for use in single cell applications. A block diagram is shown for the ZXSC100 on page 2.

A shutdown circuit turns the device on or off at $V_{CC} = 1V$ with a hysteresis of typically 80mV. At start up, comparator Comp1 turns the driver circuit and therefore the external switching transistor on. This circuit will remain active until the feedback voltage at the pin FB rises above V_{REF} , which is set to 730mV. An external resistive divider on the FB pin sets the output voltage level.

Comparator Comp2 forces the driver circuit and the external switching transistor off, if the voltage at I_{SENSE} exceeds 25mV. The voltage at I_{SENSE} is taken from a current sense resistor connected in series with the emitter of the switching transistor.

A monostable following the output of Comp2 extends the turn-off time of the output stage by a minimum of 2 μ s. This ensures that there is sufficient time to discharge the inductor coil before the next on period. The AND gate between the monostable and Comp1 output ensures that the switching transistor always remains on until the I_{SENSE} threshold is reached and that the minimum discharge period is always asserted. The pulse width is constant, the pulse frequency varies with the output load.

The driver circuit supplies the external switching transistor with a defined current, which is programmed by an external resistor connected between the RE pin and V_{CC} . The internal reference voltage for the circuit is 25mV below V_{CC} . To maximise efficiency the external transistor is switched quickly, typically being forced off within 20ns.

In higher power applications more current can be supplied to the switching transistor by using a further external component. The driver transistor in the IC can be bypassed with the addition of a discrete PNP. More information on this circuit configuration can be found in the applications section.

Application Information

The following section is a design guide for optimum converter performance.

Switching Transistor Selection

The choice of switching transistor has a major impact on the DC-DC converter efficiency. For optimum performance, a bipolar transistor with low $V_{CE(SAT)}$ and high gain is required. The majority of losses in the transistor are, 'on-state' and can be calculated by using the formula below:

$$P_{Q1} = \frac{((I_{AV} \times V_{CE(SAT)}) + (I_B \times V_{BE(SAT)})) \times T_{ON}}{(T_{ON} + T_{OFF})}$$

$$\text{where } I_{AV} = \frac{I_{PK}}{2}$$

From the calculations above the impact on converter efficiency can be seen.

External Drive Transistor Selection

For higher power applications an external transistor is required to provide the additional base drive current to the main switching transistor. For this, any small signal PNP transistor is sufficient. Please see reference designs for recommended part numbers.

Schottky Diode Selection

As with the switching transistor the Schottky rectifier diode has a major impact on the DC-DC converter efficiency. A Schottky diode with a low forward voltage and fast recovery time should be used for this application. The majority of losses in the diode are, 'on-state' and can be calculated by using the formula below:

$$P_{D1} = \frac{I_{AV} \times V_{F(MAX)} \times T_{DIS}}{(T_{ON} + T_{OFF})}$$

$$\text{where } I_{AV} = \frac{I_{PK}}{2}$$

The diode should be selected so that the maximum forward current is greater or equal to the maximum peak current in the inductor, and the maximum reverse voltage is greater or equal to the output voltage. The Diodes ZHCS1000 meets these needs. A data sheet for the ZHCS1000 is available on the Diodes web site or through your local Diodes sales office. Outline information is included in the characteristics section of this data sheet.

The inductor value must be chosen to satisfy performance, cost and size requirements of the overall solution. For the reference designs we recommend an inductor value of 22 μ H with a core saturation current rating greater than the converter peak current value.

Inductor selection has a significant impact on the converter efficiency. For applications where efficiency is critical, a 5% improvement can be achieved with a high performance inductor. This should be selected with a core saturation current rating much higher than the peak current of the converter, say 3 times greater. The resultant reduction in core losses brings about the efficiency improvement.

Peak Current Definition

The peak current rating is a design parameter whose value is dependent upon the overall application. For the reference designs, a peak current of 1.2A was chosen to ensure that the converter could provide the required output power.

In general, the I_{PK} value must be chosen to ensure that the switching transistor, Q1, is in full saturation with maximum output power conditions, assuming worse-case input voltage and transistor gain under all operating temperature extremes.

Once I_{PK} is decided the value of R_{SENSE} can be determined by:

$$R_{SENSE} = \frac{V_{ISENSE}}{I_{PK}}$$

Application Information (cont.)

Output Power Definition

By making the above assumptions for the inductor and I_{PK} the output power can be determined by:

$$\text{Output Power} = \frac{(V_{OUT} - V_{IN}) \times I_{PK} \times T_{DIS}}{2 \times (T_{ON} + T_{OFF})}$$

where

$$T_{ON} = \frac{I_{PK} \times L}{V_{IN}}$$

and

$$T_{DIS} = \frac{I_{PK} \times L}{(V_{OUT} - V_{IN})}$$

Note: V_{OUT} = output voltage + rectifier diode VF

Figure 1 shows the discontinuous inductor current and the relationship between output power, T_{ON} , T_{DIS} and T_{OFF} .

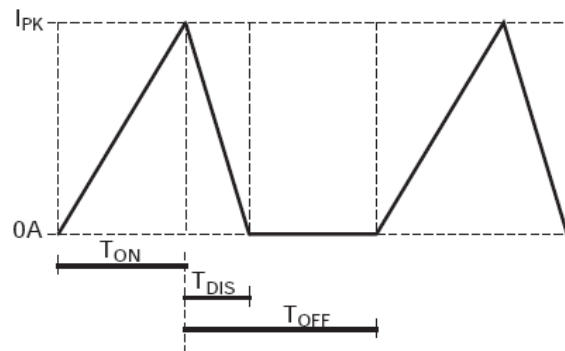

Fig. 1 Discontinuous Inductor Current

Output Capacitors

Output capacitors are a critical choice in the overall performance of the solution. They are required to filter the output and supply load transient currents. There are three parameters which are paramount in the selection of the output capacitors; their capacitance value, I_{RIPPLE} and ESR. The capacitance value is selected to meet the load transient requirements. The capacitors I_{RIPPLE} rating must meet or exceed the current ripple of the solution.

The ESR of the output capacitor can also affect loop stability and transient performance. The capacitors selected for the solution, and indicated in the reference designs, are optimised to provide the best overall performance.

Input Capacitors

The input capacitor is chosen for its voltage and RMS current rating. The use of low ESR electrolytic or tantalum capacitors is recommended. Capacitor values for optimum performance are suggested in the reference design section.

Also note that the ESR of the input capacitor is effectively in series with the input and hence contributes to efficiency losses in the order of $I_{RMS}^2 \times ESR$.

Application Information (cont.)

Output Voltage Adjustment

The ZXSC100 is an adjustable converter allowing the end user the maximum flexibility in output voltage selection. For adjustable operation a potential divider network is connected as indicated in the diagram.

The output voltage is determined by the equation:

$$V_{OUT} = V_{FB} (1 + R_A / R_B),$$

where $V_{FB} = 730\text{mV}$

The resistor values, R_A and R_B , should be maximised to improve efficiency and decrease battery drain. Optimisation can be achieved by providing a minimum current of $I_{FB(MAX)} = 200\text{nA}$ to the V_{BATT} pin. The output is adjustable from V_{FB} to the $(BR)V_{CEO}$ of the switching transistor, Q1.

Note: For the reference designs, R_A is assigned the label R3 and R_B the label R4.

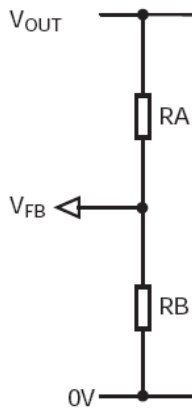

External Transistor Base Drive Selection

Optimisation of the external switching transistor base drive may be necessary for improved efficiency in low power applications. This can be achieved by introducing an external resistor between the supply and the RE pin of the ZXSC100. The resistor value can be determined by:

$$R_1 = \frac{V_{DREF}}{I_B}$$

Layout Issues

Layout is critical for the circuit to function optimally in terms of electrical efficiency, thermal considerations and noise.

For 'step-up converters' there are four main current loops, the input loop, power-switch loop, rectifier loop and output loop. The supply charging the input capacitor forms the input loop. The power-switch loop is defined when Q1 is 'on', current flows from the input through the inductor, Q1, R_{SENSE} and to ground. When Q1 is 'off', the energy stored in the inductor is transferred to the output capacitor and load via D1, forming the rectifier loop. The output loop is formed by the output capacitor supplying the load when Q1 is switched back off.

To optimise for best performance each of these loops should be kept separate from each other and interconnections made with short, thick traces thus minimising parasitic inductance, capacitance and resistance. Also the sense resistor R2 should be connected, with minimum trace length, between emitter lead of Q1 and ground, again minimising stray parasitics.

Designing with the ZXSC100

Introduction

This section refers to the ZXSC100, 3.3V/100mA output reference design and demonstrates the dynamic performance of the solution.

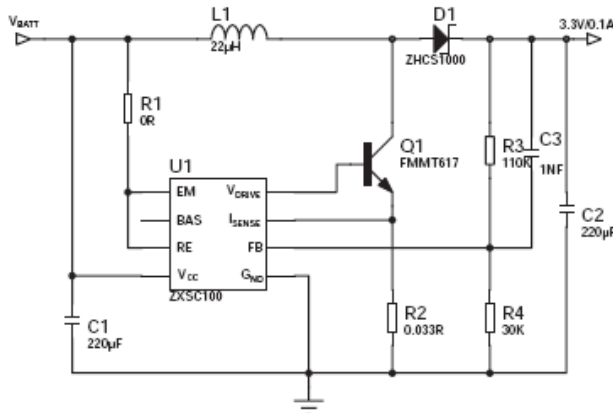

Fig. 2 ZXSC100 Low Power Solution, 3.3V/100mA Output

Efficiency

Efficiency is often quoted as one of the key parameters of a DC-DC converter. Not only does it give an instantaneous idea of heat dissipation, but also an idea as to the extent battery life can be extended. Figure 3. Shows the efficiency of the ZXSC100 low power solution. Efficiency v Output current is shown for a 3.3V output at various input voltages.

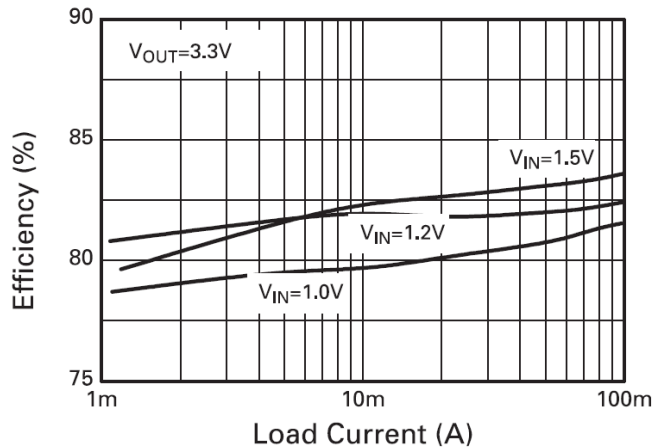

Fig. 3 ZXSC100 Efficiency vs. Output Current

Designing with the ZXSC100 (cont.)

Main Switching Waveforms

Steady state operation under constant load gives an excellent indication of ZXSC100 performance. Represented in Figure 4. is the main switching waveform, measured at the collector of Q1, indicating the transistor on-state and the diode energy transfer to the output.

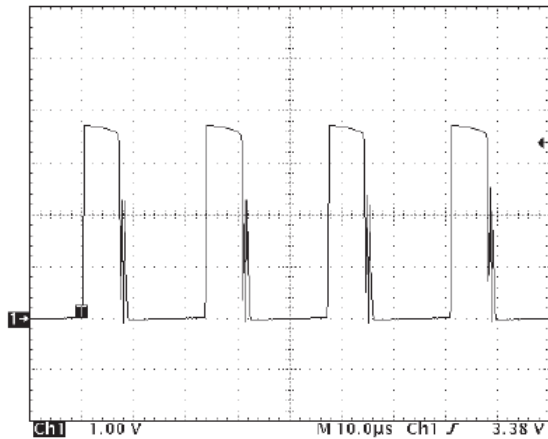

Fig. 4 Switching Waveform

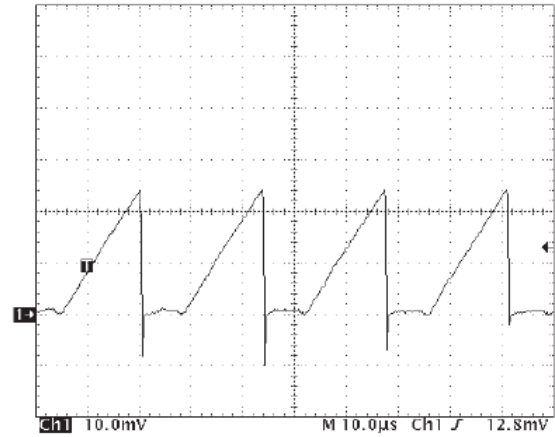

Fig. 5 I_{SENSE} Threshold

The peak switching current is derived from the threshold of the I_{SENSE} pin and the sense resistor value (see Applications section for calculations). Figure 5. shows the switching waveform associated with the I_{SENSE} pin.

Shown in Figure 6. is the discontinuous inductor current. The ramp-up current stores energy in the inductor. The switching transistor, Q1, is on during this time and has an equivalent current ramp-up, shown in Figure 7. The ramp-down current is associated with the energy being delivered to the output via the Schottky diode, D1. The diode current is equivalent to this ramp-down current and is shown in figure 8.

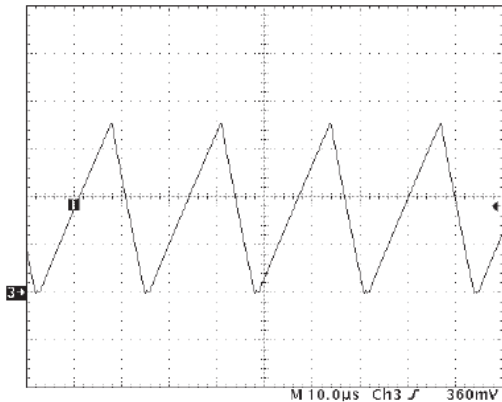

Fig. 6 Inductor Current (200mA/div)

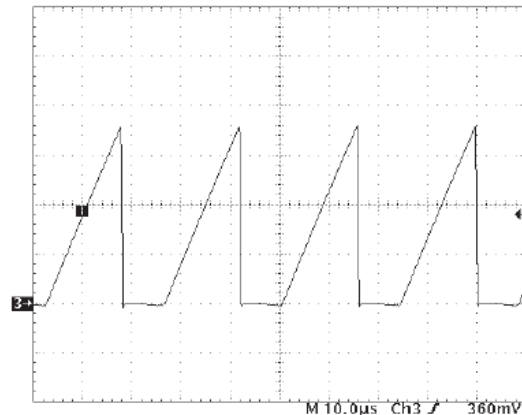

Fig. 7 Transistor Current (200mA/div)

Designing with the ZXSC100 (cont.)

Main Switching Waveforms (cont.)

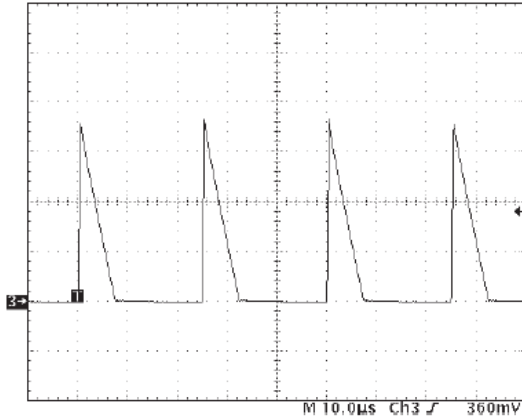

Fig. 8 Diode Current (200mA/div)

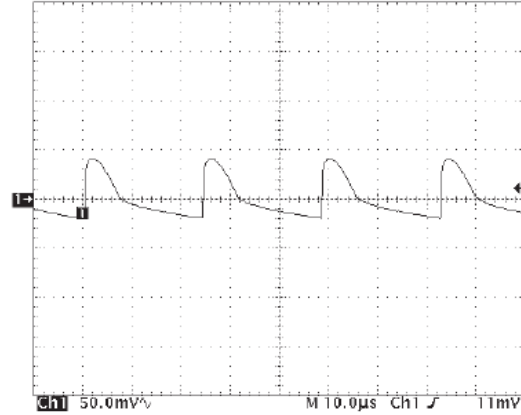

Fig. 9 Output Voltage Ripple for 3.3V/100mA output

Output Voltage Ripple

Output voltage ripple is shown in Figure 9. The circuit is operated with a 1.2V input voltage, 3.3V output voltage and 100mA load current. Output voltage ripple will be dependent, to a large extent, on the output capacitor ESR. (see Applications section for recommended capacitors).

Transient Response

Transient response to step changes in load is a critical feature in many converter circuits. The ZXSC100 operates a pulse by pulse regulation scheme and therefore corrects for changes in the output every pulse cycle, giving excellent response characteristic.

Measurement with a Power Supply

When measuring with a power supply it is important to realise that the impedance is much greater than that of a secondary battery (NiCd or NiMH). To simulate the lower impedance of the battery x10 low ESR 1000µF capacitors were placed in parallel at the input of the converter. All the dynamic performance measurements were taken using this technique.

Ordering Information

Device	Package	Part Marking	Status	7" Tape and Reel	
				Quantity	Part Number Suffix
ZXSC100N8TA	SO-8	ZXSC100	Active	500/Tape & Reel	TA
ZXSC100X8TA	MSOP-8	ZXSC100	Obsolete	1000/Tape & Reel	TA

Package Outline Dimensions (All Dimensions in mm)

SO-8

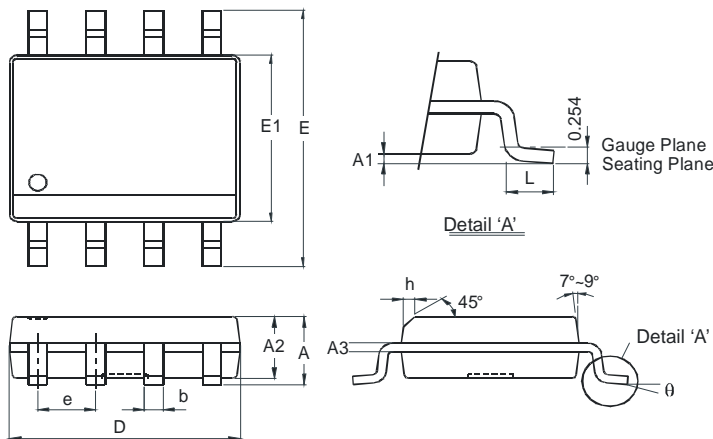

SO-8		
Dim	Min	Max
A	-	1.75
A1	0.10	0.20
A2	1.30	1.50
A3	0.15	0.25
b	0.3	0.5
D	4.85	4.95
E	5.90	6.10
E1	3.85	3.95
e	1.27 Typ	
h	-	0.35
L	0.62	0.82
θ	0°	8°
All Dimensions in mm		

IMPORTANT NOTICE

DIODES INCORPORATED MAKES NO WARRANTY OF ANY KIND, EXPRESS OR IMPLIED, WITH REGARDS TO THIS DOCUMENT, INCLUDING, BUT NOT LIMITED TO, THE IMPLIED WARRANTIES OF MERCHANTABILITY AND FITNESS FOR A PARTICULAR PURPOSE (AND THEIR EQUIVALENTS UNDER THE LAWS OF ANY JURISDICTION).

Diodes Incorporated and its subsidiaries reserve the right to make modifications, enhancements, improvements, corrections or other changes without further notice to this document and any product described herein. Diodes Incorporated does not assume any liability arising out of the application or use of this document or any product described herein; neither does Diodes Incorporated convey any license under its patent or trademark rights, nor the rights of others. Any Customer or user of this document or products described herein in such applications shall assume all risks of such use and will agree to hold Diodes Incorporated and all the companies whose products are represented on Diodes Incorporated website, harmless against all damages.

Diodes Incorporated does not warrant or accept any liability whatsoever in respect of any products purchased through unauthorized sales channel.

Should Customers purchase or use Diodes Incorporated products for any unintended or unauthorized application, Customers shall indemnify and hold Diodes Incorporated and its representatives harmless against all claims, damages, expenses, and attorney fees arising out of, directly or indirectly, any claim of personal injury or death associated with such unintended or unauthorized application.

Products described herein may be covered by one or more United States, international or foreign patents pending. Product names and markings noted herein may also be covered by one or more United States, international or foreign trademarks.

LIFE SUPPORT

Diodes Incorporated products are specifically not authorized for use as critical components in life support devices or systems without the express written approval of the Chief Executive Officer of Diodes Incorporated. As used herein:

A. Life support devices or systems are devices or systems which:

1. are intended to implant into the body, or
2. support or sustain life and whose failure to perform when properly used in accordance with instructions for use provided in the labeling can be reasonably expected to result in significant injury to the user.

B. A critical component is any component in a life support device or system whose failure to perform can be reasonably expected to cause the failure of the life support device or to affect its safety or effectiveness.

Customers represent that they have all necessary expertise in the safety and regulatory ramifications of their life support devices or systems, and acknowledge and agree that they are solely responsible for all legal, regulatory and safety-related requirements concerning their products and any use of Diodes Incorporated products in such safety-critical, life support devices or systems, notwithstanding any devices- or systems-related information or support that may be provided by Diodes Incorporated. Further, Customers must fully indemnify Diodes Incorporated and its representatives against any damages arising out of the use of Diodes Incorporated products in such safety-critical, life support devices or systems.

Copyright © 2012, Diodes Incorporated

www.diodes.com