

## FEATURES

- Full Featured Li-Ion/Polymer Charger/PowerPath™ Controller with Instant-On Operation
- Triple Adjustable High Efficiency Step-Down Switching Regulators (800mA, 500mA, 500mA I<sub>OUT</sub>)
- I<sup>2</sup>C Adjustable SW Slew Rates for EMI Reduction
- High Temperature Battery Voltage Reduction Improves Safety and Reliability
- Overvoltage Protection Controller for USB (V<sub>BUS</sub>)/Wall Inputs Provide Protection to 30V
- 1.5A Maximum Charge Current with Thermal Limiting
- Battery Float Voltage: 4.2V
- Pushbutton ON/OFF Control with System Reset
- Dual 150mA Current Limited LDOs
- Start-Up Timing Compatible with SiRF Atlas IV Processor
- Small 4mm × 7mm 44-Pin QFN Package

## APPLICATIONS

- PNDs, DMB/DVB-H, Digital/Satellite Radio, Media Players
- Portable Industrial/Medical Products
- Other USB-Based Handheld Products

## DESCRIPTION

The LTC<sup>®</sup>3677-3 is a highly integrated power management IC for single-cell Li-Ion/Polymer battery applications. It includes a PowerPath manager with automatic load prioritization, a battery charger, an ideal diode, input overvoltage protection and numerous other internal protection features. The LTC3677-3 is designed to accurately charge from current limited supplies such as USB by automatically reducing charge current such that the sum of the load current and the charge current does not exceed the programmed input current limit (100mA or 500mA modes). The LTC3677-3 reduces the battery voltage at elevated temperatures to improve safety and reliability. The three step-down switching regulators and two LDOs provide a wide range of available supplies. The LTC3677-3 also includes a pushbutton input to control power sequencing and system reset. The LTC3677-3 has pushbutton timing and sequencing designed to support the SiRF Atlas IV processor. The LTC3677-3 is available in a low profile 4mm × 7mm × 0.75mm 44-pin QFN package.

LT, LT, LTC, LTM, Linear Technology, PowerPath, Burst Mode and the Linear logo are registered trademarks and Bat-Track and Hot Swap are trademarks of Linear Technology Corporation. All other trademarks are the property of their respective owners. Protected by U.S. Patents, including 6522118, 6700364, 7511390, 5481178, 6580258. Other patents pending.

## TYPICAL APPLICATION

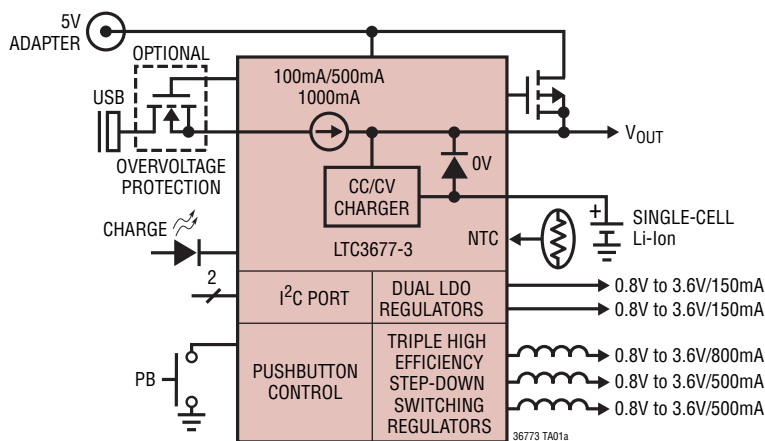

### High Temperature BAT Discharge

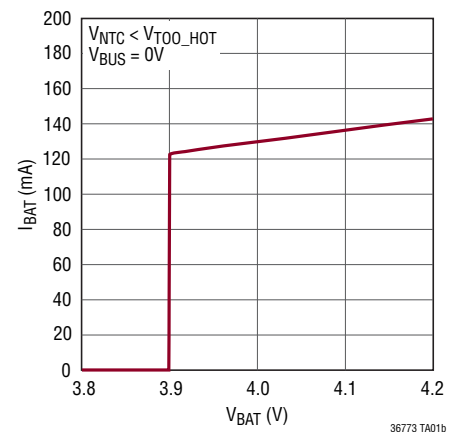

**TABLE OF CONTENTS**

**Features** ..... 1

**Applications** ..... 1

**Typical Application** ..... 1

**Description**..... 1

**Absolute Maximum Ratings**..... 3

**Order Information**..... 3

**Pin Configuration** ..... 3

**Electrical Characteristics**..... 4

**Typical Performance Characteristics** ..... 10

**Pin Functions** ..... 15

**Block Diagram**..... 18

**Operation**..... 19

    PowerPath OPERATION ..... 19

    Low Dropout Linear Regulator Operation ..... 27

    Step-Down Switching Regulator Operation..... 28

    I<sup>2</sup>C Operation ..... 32

    Pushbutton Interface Operation ..... 36

    Layout and Thermal Considerations ..... 40

**Typical Application** ..... 42

**Package Description** ..... 43

**Typical Application** ..... 44

**Related Parts** ..... 44

## ABSOLUTE MAXIMUM RATINGS

(Notes 1, 2, 3)

$V_{BUS}$ , $V_{OUT}$ , $V_{IN12}$ , $V_{IN3}$ , $V_{INLDO1}$ , $V_{INLDO2}$ , WALL $t < 1\text{ms}$ and Duty Cycle $< 1\%$ .....	-0.3V to 7V
Steady State .....	-0.3V to 6V
CHRG, BAT, PWR_ON, EXTPWR, PBSTAT, PGOOD, FB1, FB2, FB3, LDO1, LDO1_FB, LDO2, LDO2_FB, DV <sub>CC</sub> , SCL, SDA, EN3 .....	-0.3V to 6V
NTC, PROG, CLPROG, $\overline{\text{ON}}$ , I <sub>LIM0</sub> , I <sub>LIM1</sub> (Note 4).....	-0.3V to $V_{CC} + 0.3\text{V}$
I <sub>VBUS</sub> , I <sub>VOUT</sub> , I <sub>BAT</sub> , Continuous (Note 16).....	2A
I <sub>SW3</sub> , Continuous (Note 16).....	850mA
I <sub>SW2</sub> , I <sub>SW1</sub> , Continuous (Note 16).....	600mA
I <sub>LDO1</sub> , I <sub>LDO2</sub> , Continuous (Note 16) .....	200mA
I <sub>CHRG</sub> , I <sub>ACPR</sub> , I <sub>EXTPWR</sub> , I <sub>PBSTAT</sub> , I <sub>PGOOD</sub> .....	75mA
I <sub>OVSENS</sub> .....	10mA
I <sub>CLPROG</sub> , I <sub>PROG</sub> .....	2mA
Operating Junction Temperature Range (Note 2) .....	-40°C to 85°C
Maximum Junction Temperature .....	110°C
Storage Temperature Range .....	-65°C to 125°C

## PIN CONFIGURATION

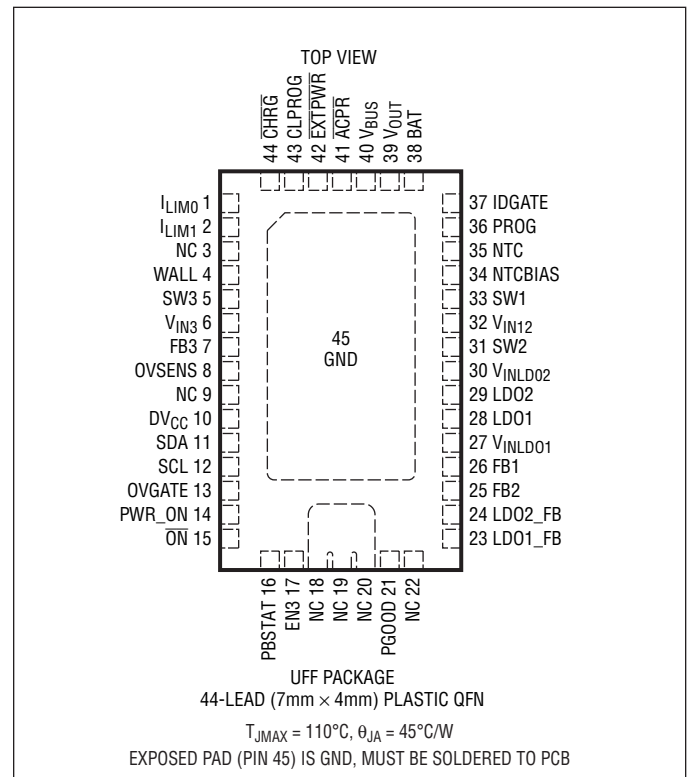

## ORDER INFORMATION

LEAD FREE FINISH	TAPE AND REEL	PART MARKING	PACKAGE DESCRIPTION	TEMPERATURE RANGE
LTC3677EUFF-3#PBF	LTC3677EUFF-3#TRPBF	36773	44-Lead (4mm × 7mm) Plastic QFN	-40°C to 85°C

Consult LTC Marketing for parts specified with wider operating temperature ranges.

Consult LTC Marketing for information on non-standard lead based finish parts.

For more information on lead free part marking, go to: <http://www.linear.com/leadfree/>

For more information on tape and reel specifications, go to: <http://www.linear.com/tapeandree/>

## ELECTRICAL CHARACTERISTICS Power Manager. The ● denotes the specifications which apply over the full operating junction temperature range, otherwise specifications are at $T_J = 25^\circ\text{C}$ . $V_{BUS} = 5\text{V}$ , $V_{BAT} = 3.8\text{V}$ , $I_{LIM0} = I_{LIM1} = 5\text{V}$ , $WALL = 0\text{V}$ , $V_{INLDO2} = V_{INLDO1} = V_{IN12} = V_{IN3} = V_{OUT}$ , $R_{PROG} = 2\text{k}$ , $R_{CLPROG} = 2.1\text{k}$ , unless otherwise noted.

SYMBOL	PARAMETER	CONDITIONS	MIN	TYP	MAX	UNITS
<b>Input Power Supply</b>						
$V_{BUS}$	Input Supply Voltage		4.35		5.5	V
$I_{BUS\_LIM}$	Total Input Current (Note 5)	$I_{LIM0} = 5\text{V}$ , $I_{LIM1} = 5\text{V}$ (1x Mode) ● $I_{LIM0} = 0\text{V}$ , $I_{LIM1} = 0\text{V}$ (5x Mode) ● $I_{LIM0} = 0\text{V}$ , $I_{LIM1} = 5\text{V}$ (10x Mode) ●	80 450 900	90 475 950	100 500 1000	mA mA mA
$I_{BUSQ}$	Input Quiescent Current, POFF State	1x, 5x, 10x Modes $I_{LIM0} = 5\text{V}$ , $I_{LIM1} = 0\text{V}$ (Suspend Mode)		0.42 0.05		mA mA
$h_{CLPROG}$	Ratio of Measured $V_{BUS}$ Current to CLPROG Program Current			1000		mA/mA
$V_{CLPROG}$	CLPROG Servo Voltage in Current Limit	1x Mode 5x Mode 10x Mode		0.2 1.0 2.0		V V V
$V_{UVLO}$	$V_{BUS}$ Undervoltage Lockout	Rising Threshold Falling Threshold	3.5	3.8 3.7	3.9	V V
$V_{DUVLO}$	$V_{BUS}$ to $V_{OUT}$ Differential Undervoltage Lockout	Rising Threshold Falling Threshold		50 -50	100	mV mV
$R_{ON\_ILIM}$	Input Current Limit Power FET On-Resistance (Between $V_{BUS}$ and $V_{OUT}$ )			200		m $\Omega$
<b>Battery Charger</b>						
$V_{FLOAT}$	$V_{BAT}$ Regulated Output Voltage	LTC3677-3 LTC3677-3, $0 \leq T_J \leq 85^\circ\text{C}$	4.179 4.165	4.200 4.200	4.221 4.235	V V
$I_{CHG}$	Constant-Current Mode Charge Current IC Not in Thermal Limit	$R_{PROG} = 1\text{k}$ , Input Current Limit = 2A ● $R_{PROG} = 2\text{k}$ , Input Current Limit = 1A ● $R_{PROG} = 5\text{k}$ , Input Current Limit = 0.4A ●	950 465 180	1000 500 200	1050 535 220	mA mA mA
$I_{BATQ\_OFF}$	Battery-Drain Current, POFF State, Buck3 Disabled, No Load (Note 14)	$V_{BAT} = 4.3\text{V}$ , Charger Time Out $V_{BUS} = 0\text{V}$		6 55	27 100	$\mu\text{A}$ $\mu\text{A}$
$I_{BATQ\_ON}$	Battery-Drain Current, PON State, Buck3 Enabled (Notes 10, 14)	$V_{BUS} = 0\text{V}$ , $I_{OUT} = 0\mu\text{A}$ , No Load On Supplies, Burst Mode <sup>®</sup> Operation		130	200	$\mu\text{A}$
$V_{PROG,CHG}$	PROG Pin Servo Voltage	$V_{BAT} > V_{TRKL}$		1.000		V
$V_{PROG,TRKL}$	PROG Pin Servo Voltage in Trickle Charge	$V_{BAT} < V_{TRKL}$		0.100		V
$h_{PROG}$	Ratio of $I_{BAT}$ to PROG Pin Current			1000		mA/mA
$I_{TRKL}$	Trickle Charge Current	$V_{BAT} < V_{TRKL}$	40	50	60	mA
$V_{TRKL}$	Trickle Charge Rising Threshold Trickle Charge Falling Threshold	$V_{BAT}$ Rising $V_{BAT}$ Falling	2.5	2.9 2.75	3.0	V V
$\Delta V_{RECHRG}$	Recharge Battery Threshold Voltage	Threshold Voltage Relative to $V_{FLOAT}$	-75	-100	-125	mV
$t_{TERM}$	Safety Timer Termination Period	Timer Starts when $V_{BAT} = V_{FLOAT} - 50\text{mV}$	3.2	4	4.8	Hour
$t_{BADBAT}$	Bad Battery Termination Time	$V_{BAT} < V_{TRKL}$	0.4	0.5	0.6	Hour
$h_{C/10}$	End-of-Charge Indication Current Ratio	(Note 6)	0.085	0.1	0.11	mA/mA
$R_{ON\_CHG}$	Battery Charger Power FET On-Resistance (Between $V_{OUT}$ and BAT)			200		m $\Omega$
$T_{LIM}$	Junction Temperature in Constant-Temperature Mode			110		$^\circ\text{C}$

**ELECTRICAL CHARACTERISTICS** Power Manager. The ● denotes the specifications which apply over the full operating junction temperature range, otherwise specifications are at  $T_J = 25^\circ\text{C}$ .  $V_{\text{BUS}} = 5\text{V}$ ,  $V_{\text{BAT}} = 3.8\text{V}$ ,  $I_{\text{LIM0}} = I_{\text{LIM1}} = 5\text{V}$ ,  $V_{\text{WALL}} = 0\text{V}$ ,  $V_{\text{INLDO2}} = V_{\text{INLDO1}} = V_{\text{IN12}} = V_{\text{IN3}} = V_{\text{OUT}}$ ,  $R_{\text{PROG}} = 2\text{k}$ ,  $R_{\text{CLPROG}} = 2.1\text{k}$ , unless otherwise noted.

SYMBOL	PARAMETER	CONDITIONS	MIN	TYP	MAX	UNITS
<b>NTC, Battery Discharge Protection</b>						
$V_{\text{COLD}}$	Cold Temperature Fault Threshold Voltage	Rising NTC Voltage Hysteresis	75	76 1.3	77	$\%V_{\text{NTCBIAS}}$ $\%V_{\text{NTCBIAS}}$
$V_{\text{HOT}}$	Hot Temperature Fault Threshold Voltage	Falling NTC Voltage Hysteresis	34	35 1.3	36	$\%V_{\text{NTCBIAS}}$ $\%V_{\text{NTCBIAS}}$
$V_{\text{T00\_HOT}}$	NTC Discharge Threshold Voltage	Falling NTC Voltage Hysteresis	24.5	25.5 50	26.5	$\%V_{\text{NTCBIAS}}$ mV
$I_{\text{NTC}}$	NTC Leakage Current	$V_{\text{NTC}} = V_{\text{BUS}} = 5\text{V}$	-50		50	nA
$I_{\text{BAT2HOT}}$	BAT Discharge Current	$V_{\text{BAT}} = 4.1\text{V}$ , $\text{NTC} < V_{\text{T00\_HOT}}$		170		mA
$V_{\text{BAT2HOT}}$	BAT Discharge Threshold	$I_{\text{BAT}} < 0.1\text{mA}$ , $\text{NTC} < V_{\text{T00\_HOT}}$		3.9		V
<b>Ideal Diode</b>						
$V_{\text{FWD}}$	Forward Voltage Detection	$I_{\text{OUT}} = 10\text{mA}$	5	15	25	mV
$R_{\text{DROPOUT}}$	Diode On-Resistance, Dropout	$I_{\text{OUT}} = 200\text{mA}$		200		$\text{m}\Omega$
$I_{\text{MAX}}$	Diode Current Limit	(Note 7)		3.6		A
<b>Overvoltage Protection</b>						
$V_{\text{OVCUTOFF}}$	Overvoltage Protection Threshold	Rising Threshold, $R_{\text{OVSENS}} = 6.2\text{k}$	6.10	6.35	6.70	V
$V_{\text{OVGATE}}$	OVGATE Output Voltage	Input Below $V_{\text{OVCUTOFF}}$ Input Above $V_{\text{OVCUTOFF}}$		$1.88 \cdot V_{\text{OVSENS}}$ 0	12	V V
$I_{\text{OVSENSQ}}$	OVSENS Quiescent Current	$V_{\text{OVSENS}} = 5\text{V}$		40		$\mu\text{A}$
$t_{\text{RISE}}$	OVGATE Time to Reach Regulation	$C_{\text{OVGATE}} = 1\text{nF}$		2.5		ms
<b>Wall Adapter and High Voltage Buck Output Control</b>						
$V_{\text{ACPR}}$	ACPR Pin Output High Voltage ACPR Pin Output Low Voltage	$I_{\text{ACPR}} = 0.1\text{mA}$ $I_{\text{ACPR}} = 1\text{mA}$	$V_{\text{OUT}} - 0.3$	$V_{\text{OUT}}$ 0	0.3	V V
$V_{\text{W}}$	Absolute Wall Input Threshold Voltage	$V_{\text{WALL}}$ Rising $V_{\text{WALL}}$ Falling	3.1	4.3 3.2	4.45	V V
$\Delta V_{\text{W}}$	Differential Wall Input Threshold Voltage	$V_{\text{WALL}} - V_{\text{BAT}}$ Falling $V_{\text{WALL}} - V_{\text{BAT}}$ Rising	0	25 75	100	mV mV
$I_{\text{QWALL}}$	Wall Operating Quiescent Current	$I_{\text{WALL}} + I_{\text{VOUT}}$ , $I_{\text{BAT}} = 0\text{mA}$ , $\text{WALL} = V_{\text{OUT}} = 5\text{V}$		440		$\mu\text{A}$
<b>Logic (<math>I_{\text{LIM0}}</math>, <math>I_{\text{LIM1}}</math> and <math>\text{CHRG}</math>)</b>						
$V_{\text{IL}}$	Input Low Voltage	$I_{\text{LIM0}}$ , $I_{\text{LIM1}}$			0.4	V
$V_{\text{IH}}$	Input High Voltage	$I_{\text{LIM0}}$ , $I_{\text{LIM1}}$	1.2			V
$I_{\text{PD}}$	Static Pull-Down Current	$I_{\text{LIM0}}$ , $I_{\text{LIM1}}$ ; $V_{\text{PIN}} = 1\text{V}$		2		$\mu\text{A}$
$V_{\text{CHRG}}$	CHRG Pin Output Low Voltage	$I_{\text{CHRG}} = 10\text{mA}$		0.15	0.4	V
$I_{\text{CHRG}}$	CHRG Pin Input Current	$V_{\text{BAT}} = 4.5\text{V}$ , $V_{\text{CHRG}} = 5\text{V}$		0	1	$\mu\text{A}$

## ELECTRICAL CHARACTERISTICS

I<sup>2</sup>C Interface. The ● denotes the specifications which apply over the full operating junction temperature range, otherwise specifications are at T<sub>J</sub> = 25°C. DV<sub>CC</sub> = 3.3V, V<sub>OUT</sub> = 3.8V, unless otherwise noted.

SYMBOL	PARAMETER	CONDITIONS	MIN	TYP	MAX	UNITS
DV <sub>CC</sub>	Input Supply Voltage		1.6		5.5	V
I <sub>DVCC</sub>	DV <sub>CC</sub> Supply Current	SCL = 400kHz SCL = SDA = 0kHz			10 1	μA μA
V <sub>DVCC,UVLO</sub>	DV <sub>CC</sub> UVLO			1.0		V
V <sub>IH</sub>	Input High Voltage			50	70	%DV <sub>CC</sub>
V <sub>IL</sub>	Input Low Voltage		30	50		%DV <sub>CC</sub>
I <sub>IH</sub>	Input High Leakage Current	SDA = SCL = DV <sub>CC</sub> = 5.5V	-1		1	μA
I <sub>IL</sub>	Input Low Leakage Current	SDA = SCL = 0V, DV <sub>CC</sub> = 5.5V	-1		1	μA
V <sub>OL</sub>	SDA Output Low Voltage	I <sub>SDA</sub> = 3mA			0.4	V

### Timing Characteristics (Note 8) (All Values Are Referenced to V<sub>IH</sub> and V<sub>IL</sub>)

f <sub>SCL</sub>	SCL Clock Frequency				400	kHz
t <sub>LOW</sub>	Low Period of the SCL Clock		1.3			μs
t <sub>HIGH</sub>	High Period of the SCL Clock		0.6			μs
t <sub>BUF</sub>	Bus Free Time Between Stop and Start Condition		1.3			μs
t <sub>HD,STA</sub>	Hold Time After (Repeated) Start Condition		0.6			μs
t <sub>SU,STA</sub>	Set-Up Time for a Repeated Start Condition		0.6			μs
t <sub>SU,STO</sub>	Stop Condition Set-Up Time		0.6			μs
t <sub>HD,DATO</sub>	Output Data Hold Time		0		900	ns
t <sub>HD,DATI</sub>	Input Data Hold Time		0			ns
t <sub>SU,DAT</sub>	Data Set-Up Time		100			ns
t <sub>SP</sub>	Input Spike Suppression Pulse Width				50	ns

**ELECTRICAL CHARACTERISTICS** Step-Down Switching Regulators. The ● denotes the specifications which apply over the full operating junction temperature range, otherwise specifications are at  $T_J = 25^\circ\text{C}$ .  $V_{\text{OUT}} = V_{\text{IN}12} = V_{\text{IN}3} = 3.8\text{V}$ , all regulators enabled unless otherwise noted.

SYMBOL	PARAMETER	CONDITIONS	MIN	TYP	MAX	UNITS
<b>Step-Down Switching Regulators (Buck1, Buck2 and Buck3)</b>						
$V_{\text{IN}12}, V_{\text{IN}3}$	Input Supply Voltage	(Note 9)	● 2.7		5.5	V
$V_{\text{OUT}} \text{ UVLO}$	$V_{\text{OUT}}$ Falling $V_{\text{OUT}}$ Rising	$V_{\text{IN}12}$ and $V_{\text{IN}3}$ Connected to $V_{\text{OUT}}$ Through Low Impedance. Switching Regulators Are Disabled Below $V_{\text{OUT}} \text{ UVLO}$	2.5	2.7 2.8	2.9	V V
$f_{\text{OSC}}$	Oscillator Frequency		1.91	2.25	2.59	MHz
<b>800mA Step-Down Switching Regulator 3 (Buck3-Enabled via EN3, Disabled in PDN and POFF States)</b>						
$I_{\text{VIN}3\text{Q}}$	Pulse-Skipping Mode Input Current	(Note 10)		100		$\mu\text{A}$
	Burst Mode Operation Input Current	(Note 10)		20	35	$\mu\text{A}$
	Shutdown Input Current	EN3 = 0		0.01	1	$\mu\text{A}$
$I_{\text{LIM}3}$	Peak P-Channel MOSFET Current Limit	(Note 7)	1000	1400	1700	mA
$V_{\text{FB}3}$	Feedback Voltage	Pulse-Skipping Mode	● 0.78	0.8	0.82	V
		Burst Mode Operation	● 0.78	0.8	0.824	V
$I_{\text{FB}3}$	FB3 Input Current	(Note 10)	-0.05		0.05	$\mu\text{A}$
D3	Max Duty Cycle	FB3 = 0V	100			%
$R_{\text{P}3}$	$R_{\text{DS(ON)}}$ of P-Channel MOSFET			0.3		$\Omega$
$R_{\text{N}3}$	$R_{\text{DS(ON)}}$ of N-Channel MOSFET			0.4		$\Omega$
$R_{\text{SW}3\_PD}$	SW3 Pull-Down in Shutdown	EN3 = 0		10		k $\Omega$
$V_{\text{IL,EN}3}$	EN3 Input Low Voltage				0.4	V
$V_{\text{IH,EN}3}$	EN3 Input High Voltage		1.2			V
<b>500mA Step-Down Switching Regulator 2 (Buck2-Pushbutton Enabled, Third in Sequence)</b>						
$I_{\text{VIN}12\text{Q}}$	Pulse-Skipping Mode Input Current	(Note 10)		100		$\mu\text{A}$
	Burst Mode Operation Input Current	(Note 10)		20		$\mu\text{A}$
	Shutdown Input Current	POFF State		0.01	1	$\mu\text{A}$
$I_{\text{LIM}2}$	Peak P-Channel MOSFET Current Limit	(Note 7)	650	900	1200	mA
$V_{\text{FB}2}$	Feedback Voltage	Pulse-Skipping Mode	● 0.78	0.8	0.82	V
		Burst Mode Operation	● 0.78	0.8	0.824	V
$I_{\text{FB}2}$	FB2 Input Current	(Note 10)	-0.05		0.05	$\mu\text{A}$
D2	Max Duty Cycle	FB2 = 0V	100			%
$R_{\text{P}2}$	$R_{\text{DS(ON)}}$ of P-Channel MOSFET	$I_{\text{SW}2} = 100\text{mA}$		0.6		$\Omega$
$R_{\text{N}2}$	$R_{\text{DS(ON)}}$ of N-Channel MOSFET	$I_{\text{SW}2} = -100\text{mA}$		0.6		$\Omega$
$R_{\text{SW}2\_PD}$	SW2 Pull-Down in Shutdown	POFF State		10		k $\Omega$
<b>500mA Step-Down Switching Regulator 1 (Buck1-Pushbutton Enabled, Second in Sequence)</b>						
$I_{\text{VIN}12\text{Q}}$	Pulse-Skipping Mode Input Current	(Note 10)		100		$\mu\text{A}$
	Burst Mode Operation Input Current	(Note 10)		20		$\mu\text{A}$
	Shutdown Input Current			0.01	1	$\mu\text{A}$
$I_{\text{LIM}1}$	Peak P-Channel MOSFET Current Limit	(Note 7)	650	900	1200	mA
$V_{\text{FB}1}$	Feedback Voltage	Pulse-Skipping Mode	● 0.78	0.8	0.82	V
		Burst Mode Operation	● 0.78	0.8	0.824	V
$I_{\text{FB}1}$	FB1 Input Current	(Note 10)	-0.05		0.05	$\mu\text{A}$
D1	Max Duty Cycle	FB1 = 0V	100			%
$R_{\text{P}1}$	$R_{\text{DS(ON)}}$ of P-Channel MOSFET	$I_{\text{SW}1} = 100\text{mA}$		0.6		$\Omega$
$R_{\text{N}1}$	$R_{\text{DS(ON)}}$ of N-Channel MOSFET	$I_{\text{SW}1} = -100\text{mA}$		0.6		$\Omega$
$R_{\text{SW}1\_PD}$	SW1 Pull-Down in Shutdown	POFF State		10		k $\Omega$

## ELECTRICAL CHARACTERISTICS LDO Regulators. The ● denotes the specifications which apply over the full operating junction temperature range, otherwise specifications are at $T_J = 25^\circ\text{C}$ . $V_{\text{INLDO1}} = V_{\text{INLDO2}} = V_{\text{OUT}} = 3.8\text{V}$ , LDO1 and LDO2 enabled unless otherwise noted.

SYMBOL	PARAMETER	CONDITIONS	MIN	TYP	MAX	UNITS	
<b>LDO Regulator 1 (LDO1-Always On)</b>							
$V_{\text{INLDO1}}$	Input Voltage Range	$V_{\text{INLDO1}} \leq V_{\text{OUT}} + 0.3\text{V}$	●	1.65	5.5	V	
$V_{\text{OUT\_UVLO}}$	$V_{\text{OUT}}$ Falling	LDO1 Is Disabled Below $V_{\text{OUT}}$ UVLO		2.5	2.7	V	
	$V_{\text{OUT}}$ Rising			2.8	2.9	V	
$V_{\text{LDO1\_FB}}$	LDO1_FB Regulated Feedback Voltage	$I_{\text{LDO1}} = 1\text{mA}$	●	0.78	0.8	0.82	V
	LDO1_FB Line Regulation (Note 11)	$I_{\text{LDO1}} = 1\text{mA}$ , $V_{\text{IN}} = 1.65\text{V}$ to $5.5\text{V}$			0.4	mV/V	
	LDO1_FB Load Regulation (Note 11)	$I_{\text{LDO1}} = 1\text{mA}$ to $150\text{mA}$			5	$\mu\text{V}/\text{mA}$	
$I_{\text{LDO1\_OC}}$	Available Output Current		●	150		mA	
$I_{\text{LDO1\_SC}}$	Short-Circuit Output Current (Note 7)			270		mA	
$V_{\text{DROP1}}$	Dropout Voltage (Note 12)	$I_{\text{LDO1}} = 150\text{mA}$ , $V_{\text{INLDO1}} = 3.6\text{V}$		160	260	mV	
		$I_{\text{LDO1}} = 150\text{mA}$ , $V_{\text{INLDO1}} = 2.5\text{V}$		200	320	mV	
		$I_{\text{LDO1}} = 75\text{mA}$ , $V_{\text{INLDO1}} = 1.8\text{V}$		170	280	mV	
$R_{\text{LDO1\_PD}}$	Output Pull-Down Resistance in Shutdown	LDO1 Disabled		10		$\text{k}\Omega$	
$I_{\text{LDO\_FB1}}$	LDO_FB1 Input Current			-50	50	nA	
<b>LDO Regulator 2 (LDO2-Pushbutton Enabled, First in Sequence)</b>							
$V_{\text{INLDO2}}$	Input Voltage Range	$V_{\text{INLDO2}} \leq V_{\text{OUT}} + 0.3\text{V}$	●	1.65	5.5	V	
$V_{\text{OUT\_UVLO}}$	$V_{\text{OUT}}$ Falling	LDO2 is Disabled Below $V_{\text{OUT}}$ UVLO		2.5	2.7	V	
	$V_{\text{OUT}}$ Rising			2.8	2.9	V	
$V_{\text{LDO2\_FB}}$	LDO2_FB Regulated Output Voltage	$I_{\text{LDO2}} = 1\text{mA}$	●	0.78	0.8	0.82	V
	LDO2_FB Line Regulation (Note 11)	$I_{\text{LDO2}} = 1\text{mA}$ , $V_{\text{IN}} = 1.65\text{V}$ to $5.5\text{V}$			0.4	mV/V	
	LDO2_FB Load Regulation (Note 11)	$I_{\text{LDO2}} = 1\text{mA}$ to $150\text{mA}$			5	$\mu\text{V}/\text{mA}$	
$I_{\text{LDO2\_OC}}$	Available Output Current		●	150		mA	
$I_{\text{LDO2\_SC}}$	Short-Circuit Output Current (Note 7)			270		mA	
$V_{\text{DROP2}}$	Dropout Voltage (Note 12)	$I_{\text{LDO2}} = 150\text{mA}$ , $V_{\text{INLDO2}} = 3.6\text{V}$		160	260	mV	
		$I_{\text{LDO2}} = 150\text{mA}$ , $V_{\text{INLDO2}} = 2.5\text{V}$		200	320	mV	
		$I_{\text{LDO1}} = 75\text{mA}$ , $V_{\text{INLDO1}} = 1.8\text{V}$		170	280	mV	
$R_{\text{LDO2\_PD}}$	Output Pull-Down Resistance in Shutdown	LDO2 Disabled		14		$\text{k}\Omega$	
$I_{\text{LDO\_FB2}}$	LDO_FB2 Input Current			-50	50	nA	



## ELECTRICAL CHARACTERISTICS

Pushbutton Controller. The ● denotes the specifications which apply over the full operating junction temperature range, otherwise specifications are at  $T_J = 25^\circ\text{C}$ .  $V_{\text{OUT}} = 3.8\text{V}$ , unless otherwise noted.

SYMBOL	PARAMETER	CONDITIONS	MIN	TYP	MAX	UNITS
<b>Pushbutton Pin (<math>\overline{\text{ON}}</math>)</b>						
$V_{\text{OUT}}$	Pushbutton Operating Supply Range	(Note 9)	● 2.7		5.5	V
$V_{\text{OUT UVLO}}$	$V_{\text{OUT}}$ Falling $V_{\text{OUT}}$ Rising	Pushbutton is Disabled Below $V_{\text{OUT UVLO}}$	2.5	2.7 2.8	2.9	V V
$V_{\overline{\text{ON}}\_TH}$	$\overline{\text{ON}}$ Threshold Rising $\overline{\text{ON}}$ Threshold Falling		0.4	0.8 0.7	1.2	V V
$I_{\overline{\text{ON}}}$	$\overline{\text{ON}}$ Input Current	$V_{\overline{\text{ON}}} = V_{\text{OUT}}$ $V_{\overline{\text{ON}}} = 0\text{V}$	-1 -4	-9	1 -14	$\mu\text{A}$ $\mu\text{A}$
<b>Power-On Input Pin (<math>\text{PWR\_ON}</math>)</b>						
$V_{\text{PWR\_ON}}$	$\text{PWR\_ON}$ Threshold Rising $\text{PWR\_ON}$ Threshold Falling		0.4	0.8 0.7	1.2	V V
$I_{\text{PWR\_ON}}$	$\text{PWR\_ON}$ Input Current	$V_{\text{PWR\_ON}} = 3\text{V}$	-1		1	$\mu\text{A}$
<b>Status Output Pins (<math>\overline{\text{PBSTAT}}</math>, <math>\overline{\text{EXTPWR}}</math>, <math>\text{PGOOD}</math>)</b>						
$I_{\overline{\text{PBSTAT}}}$	$\overline{\text{PBSTAT}}$ Output High Leakage Current	$V_{\overline{\text{PBSTAT}}} = 3\text{V}$	-1		1	$\mu\text{A}$
$V_{\overline{\text{PBSTAT}}}$	$\overline{\text{PBSTAT}}$ Output Low Voltage	$I_{\overline{\text{PBSTAT}}} = 3\text{mA}$		0.1	0.4	V
$I_{\overline{\text{EXTPWR}}}$	$\overline{\text{EXTPWR}}$ Pin Input Current	$V_{\overline{\text{EXTPWR}}} = 3\text{V}$		0	1	$\mu\text{A}$
$V_{\overline{\text{EXTPWR}}}$	$\overline{\text{EXTPWR}}$ Pin Output Low Voltage	$I_{\overline{\text{EXTPWR}}} = 2\text{mA}$		0.15	0.4	V
$I_{\text{PGOOD}}$	$\text{PGOOD}$ Output High Leakage Current	$V_{\text{PGOOD}} = 3\text{V}$	-1		1	$\mu\text{A}$
$V_{\text{PGOOD}}$	$\text{PGOOD}$ Output Low Voltage	$I_{\text{PGOOD}} = 3\text{mA}$		0.1	0.4	V
$V_{\text{THPGOOD}}$	$\text{PGOOD}$ Threshold Voltage	(Note 13)		-8		%
<b>Pushbutton Timing Parameters</b>						
$t_{\overline{\text{ON}}\_PBSTAT1}$	$\overline{\text{ON}}$ Low Time to $\overline{\text{PBSTAT}}$ Low			50		ms
$t_{\overline{\text{ON}}\_PBSTAT2}$	$\overline{\text{ON}}$ High to $\overline{\text{PBSTAT}}$ High	$\overline{\text{PBSTAT}}$ Low $>$ $t_{\overline{\text{PBSTAT}}\_PW}$		900		$\mu\text{s}$
$t_{\overline{\text{PBSTAT}}\_PW}$	$\overline{\text{PBSTAT}}$ Minimum Pulse Width		40	50		ms
$t_{\overline{\text{ON}}\_PUP}$	$\overline{\text{ON}}$ Low Time for Power-Up			50		ms
$t_{\overline{\text{ON}}\_RST}$	$\overline{\text{ON}}$ Low to $\text{PGOOD}$ Reset Low		12	14	16.5	Seconds
$t_{\overline{\text{ON}}\_RST\_PW}$	$\text{PGOOD}$ Reset Low Pulse Width			1.8		ms
$t_{PUP\_PDN}$	Minimum Time from Power Up to Down			1		Seconds
$t_{PDN\_PUP}$	Minimum Time from Power Down to Up			1		Seconds
$t_{PWR\_ONH}$	$\text{PWR\_ON}$ High to Power-Up			50		ms
$t_{PWR\_ONL}$	$\text{PWR\_ON}$ Low to Power-Down			50		ms
$t_{PWR\_ONBK1}$	$\text{PWR\_ON}$ Power-Up Blanking	$\text{PWR\_ON}$ Low Recognized from Power-Up		1		Seconds
$t_{PWR\_ONBK2}$	$\text{PWR\_ON}$ Power-Down Blanking	$\text{PWR\_ON}$ High Recognized from Power-Down		1		Seconds
$t_{PGOODH}$	From Regulation to $\text{PGOOD}$ High	Buck1, 2 and LDO1 Within $\text{PGOOD}$ Threshold		230		ms
$t_{PGOODL}$	Bucks Disabled to $\text{PGOOD}$ Low	Bucks Disabled		44		$\mu\text{s}$
$t_{LDO2\_BK1}$	LDO2 Enable to Buck Enable		12.5	14.5	17.5	ms

**Note 1:** Stresses beyond those listed under Absolute Maximum Ratings may cause permanent damage to the device. Exposure to any Absolute Maximum Rating condition for extended periods may affect device reliability and lifetime.

**Note 2:** The LTC3677-3 is guaranteed to meet performance specifications from  $0^\circ\text{C}$  to  $85^\circ\text{C}$ . Specifications over the  $-40^\circ\text{C}$  to  $85^\circ\text{C}$  operating junction temperature range are assured by design, characterization and correlation with statistical process controls. Note that the maximum

ambient temperature is determined by specific operating conditions in conjunction with board layout, the rated package thermal resistance and other environmental factors.

**Note 3:** This IC includes over temperature protection that is intended to protect the device during momentary overload conditions. Junction temperatures will exceed  $110^\circ\text{C}$  when over temperature protection is active. Continuous operation above the specified maximum operating junction temperature may result in device degradation or failure.

## ELECTRICAL CHARACTERISTICS

**Note 4:**  $V_{CC}$  is the greater of  $V_{BUS}$ ,  $V_{OUT}$  or BAT.

**Note 5:** Total input current is the sum of quiescent current,  $I_{BUSQ}$ , and measured current given by  $V_{CLPROG}/R_{CLPROG} \cdot (h_{CLPROG} + 1)$ .

**Note 6:**  $h_{C/10}$  is expressed as a fraction of measured full charge current with indicated PROG resistor.

**Note 7:** The current limit features of this part are intended to protect the IC from short term or intermittent fault conditions. Continuous operation above the maximum specified pin current rating may result in device degradation or failure.

**Note 8:** The serial port is tested at rated operating frequency. Timing parameters are tested and/or guaranteed by design.

**Note 9:**  $V_{OUT}$  not in UVLO.

**Note 10:** Buck FB high, not switching.

**Note 11:** Measured with the LDO running unity gain with output tied to feedback pin.

**Note 12:** Dropout voltage is the minimum input to output voltage differential needed for an LDO to maintain regulation at a specified output current. When an LDO is in dropout, its output voltage will be equal to  $V_{IN} - V_{DROPO}$ .

**Note 13:** PGOOD threshold is expressed as a percentage difference from the Buck1, Buck2 and LDO1 regulation voltages. The threshold is measured from Buck1, Buck2 and LDO1 output rising.

**Note 14:** The  $I_{BATQ}$  specifications represent the total battery load assuming  $V_{INLDO1}$ ,  $V_{INLDO2}$ ,  $V_{IN12}$  and  $V_{IN3}$  are tied directly to  $V_{OUT}$ .

**Note 15:** Long-term current density rating for the part.

## TYPICAL PERFORMANCE CHARACTERISTICS $T_J = 25^\circ\text{C}$ unless otherwise specified

**Input Supply Current vs Temperature**

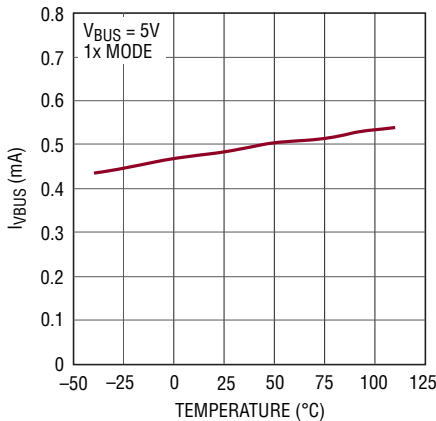

36773 G01

**Input Supply Current vs Temperature (Suspend Mode)**

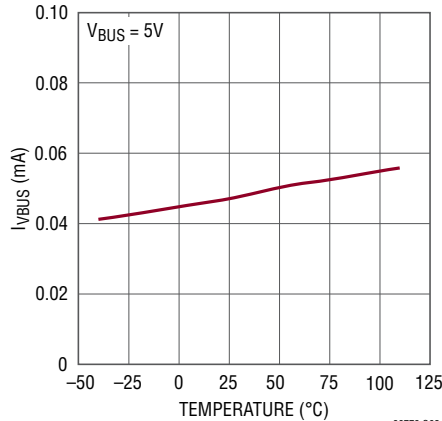

36773 G02

**Battery-Drain Current vs Temperature**

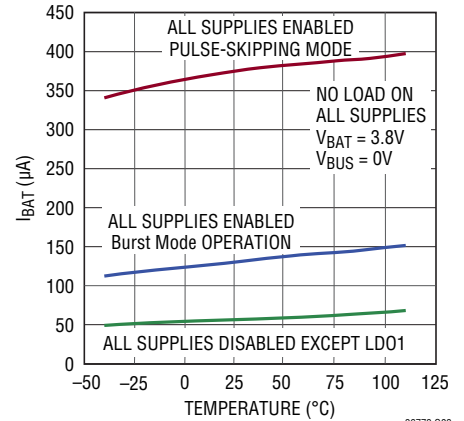

36773 G03

**TYPICAL PERFORMANCE CHARACTERISTICS**  $T_J = 25^\circ\text{C}$  unless otherwise specified

**Input Current Limit vs Temperature**

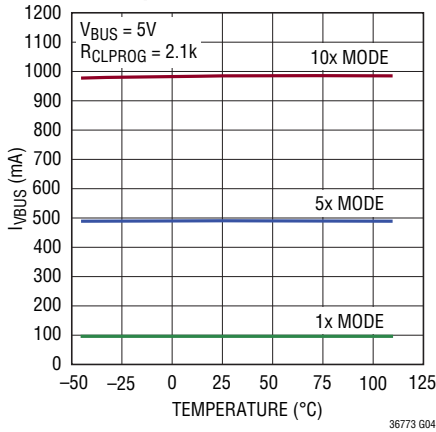

**Input  $R_{ON}$  vs Temperature**

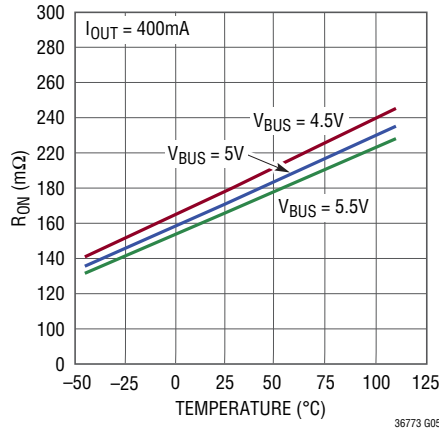

**Charge Current vs Temperature (Thermal Regulation)**

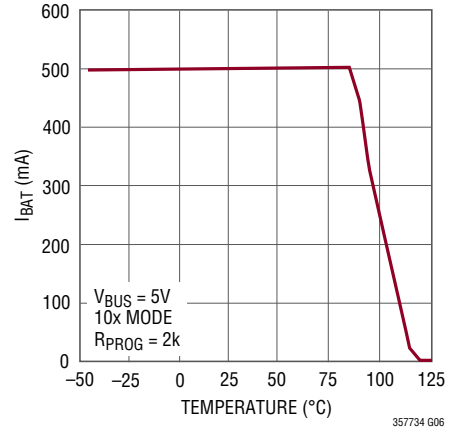

**Battery Current and Voltage vs Time**

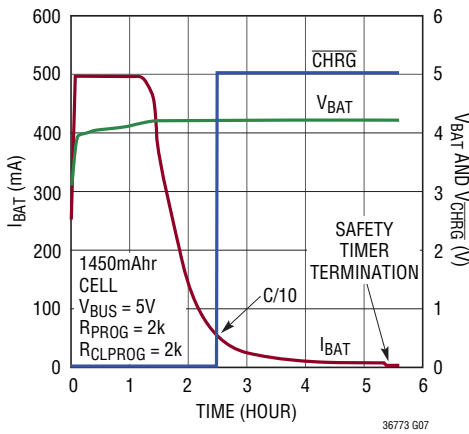

**Battery Float Voltage Load Regulation**

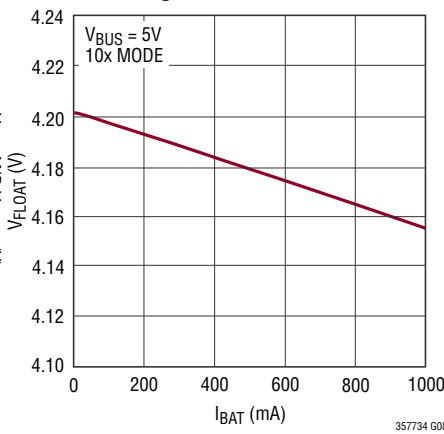

**Battery Regulation (Float) Voltage vs Temperature**

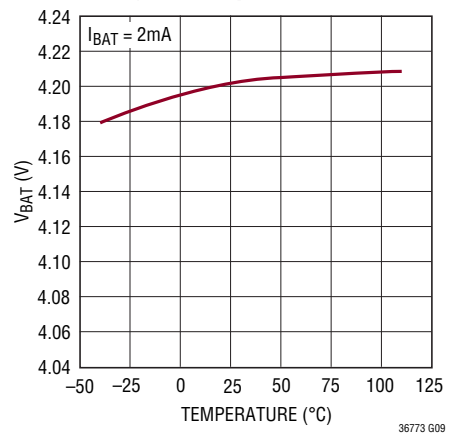

**$I_{BAT}$  vs  $V_{BAT}$**

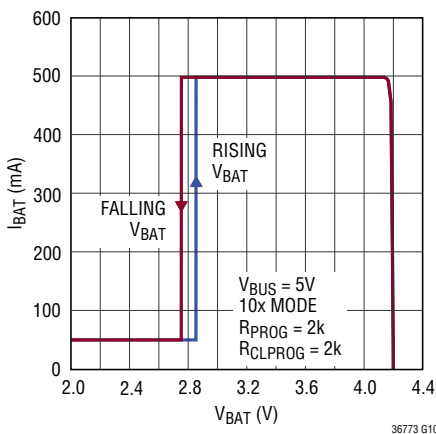

**Forward Voltage vs Ideal Diode Current (No External FET)**

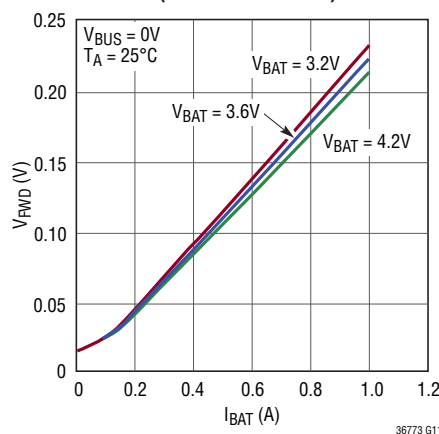

**Forward Voltage vs Ideal Diode Current (with Si2333DS External FET)**

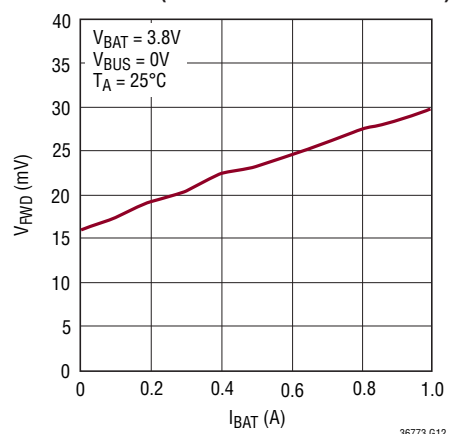

## TYPICAL PERFORMANCE CHARACTERISTICS $T_J = 25^\circ\text{C}$ unless otherwise specified

### Input Connect Waveform

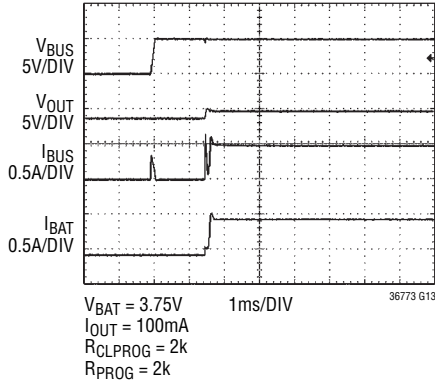

### Input Disconnect Waveform

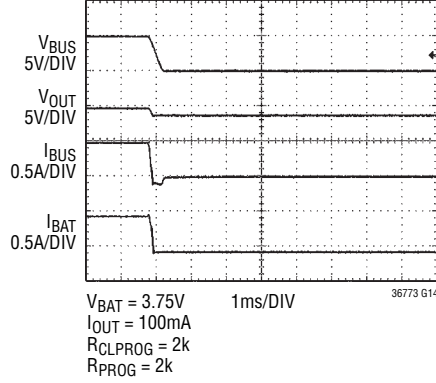

### Switching from 1x to 5x Mode

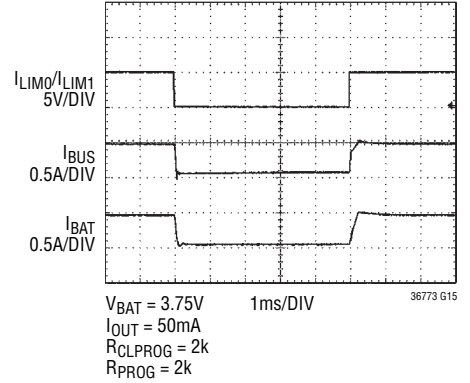

### Switching from Suspend Mode to 5x Mode

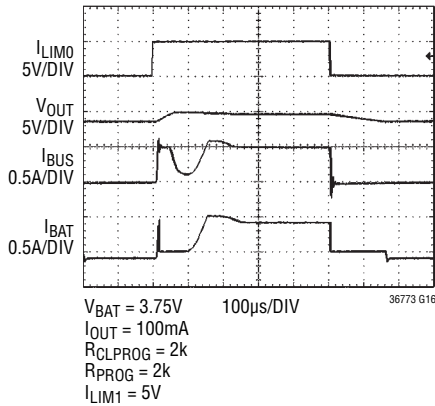

### WALL Connect Waveform

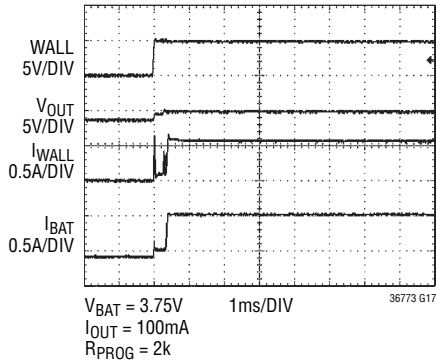

### WALL Disconnect Waveform

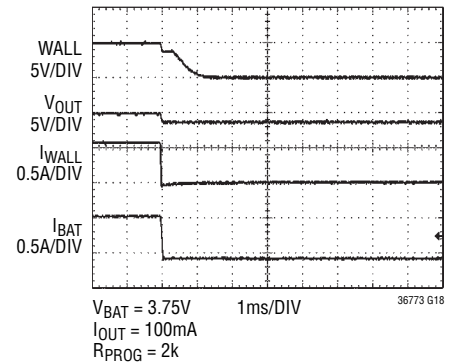

### Oscillator Frequency vs Temperature

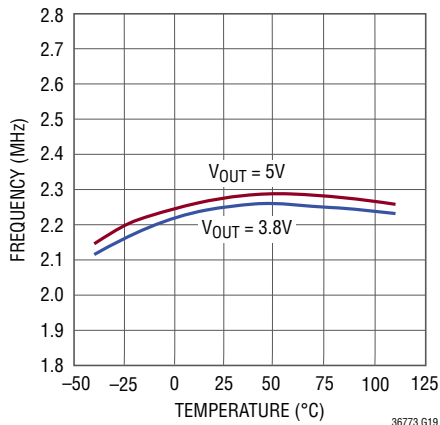

### Step-Down Switching Regulator 1 3.3V Output Efficiency vs $I_{OUT1}$

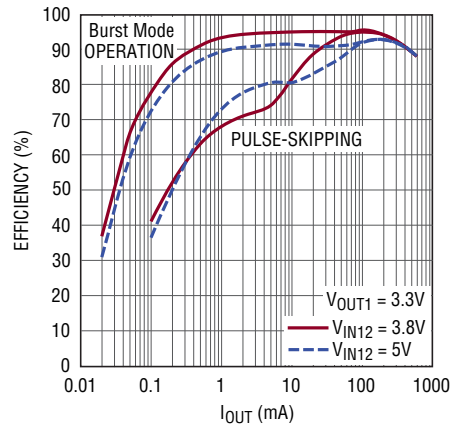

**TYPICAL PERFORMANCE CHARACTERISTICS**  $T_J = 25^\circ\text{C}$  unless otherwise specified

**Step-Down Switching Regulator 2  
1.8V Output Efficiency vs  $I_{OUT2}$**

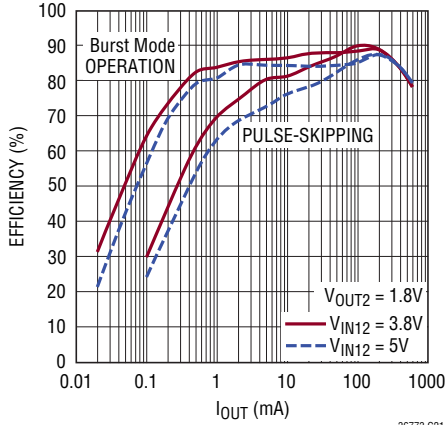

36773 G21

**Step-Down Switching Regulator 3  
1.2V Output Efficiency vs  $I_{OUT3}$**

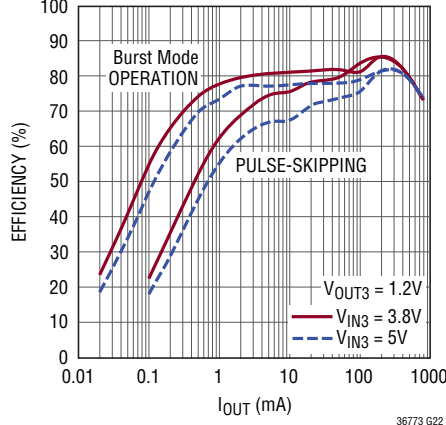

36773 G22

**Step-Down Switching Regulator 3  
2.5V Output Efficiency**

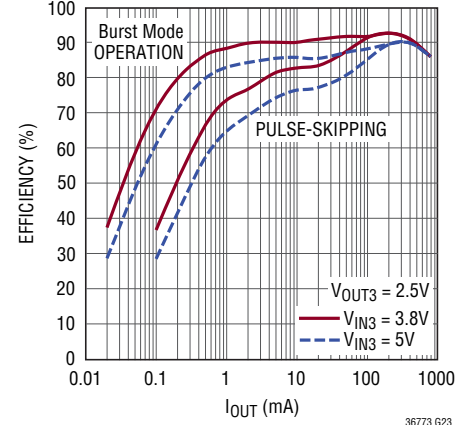

36773 G23

**Step-Down Switching Regulator  
Short-Circuit Current vs Temperature**

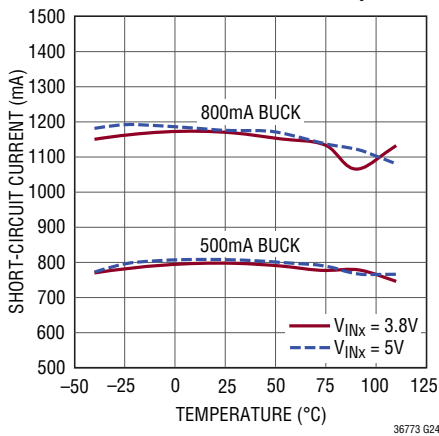

36773 G24

**Step-Down Switching Regulator  
Output Transient (Burst Mode  
Operation)**

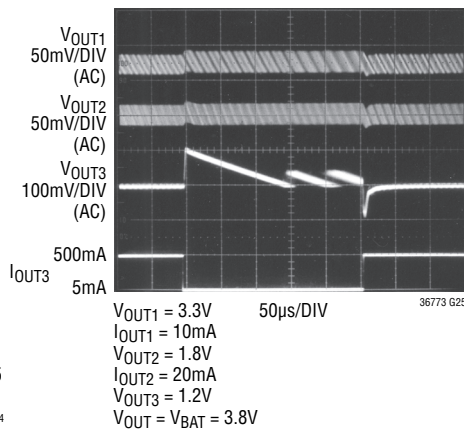

36773 G25

**Step-Down Switching Regulator  
Output Transient (Pulse-Skipping)**

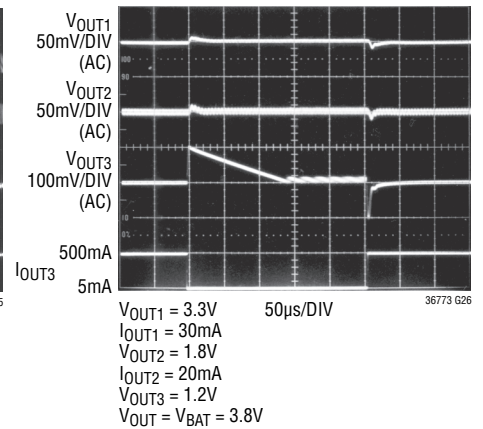

36773 G26

**Step-Down Switching Regulator  
Switch Impedance vs Temperature**

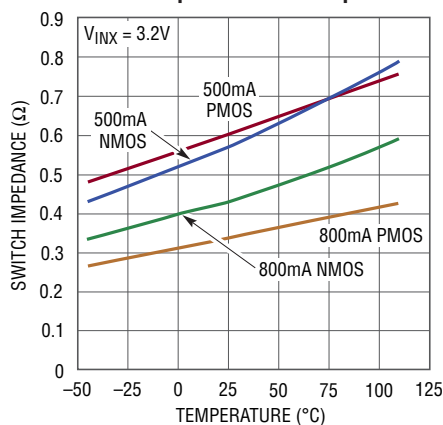

36773 G27

**800mA Step-Down Switching  
Regulator Feedback Voltage  
vs Output Current**

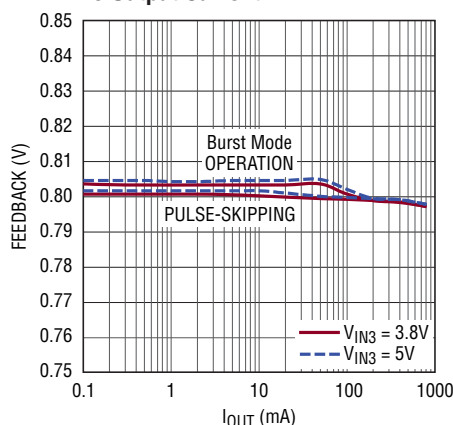

357732 G29

**500mA Step-Down Switching  
Regulator Feedback Voltage  
vs Output Current**

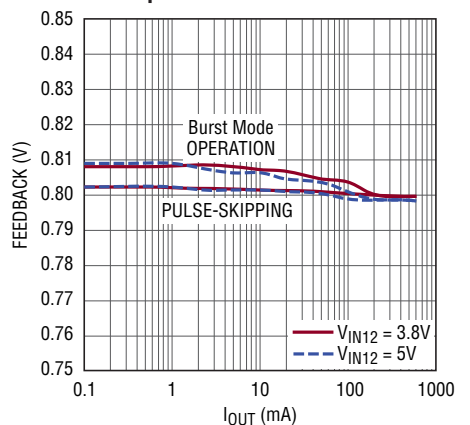

36773 G29

36773f

**TYPICAL PERFORMANCE CHARACTERISTICS**  $T_J = 25^\circ\text{C}$  unless otherwise specified

**Step-Down Switching Regulator 3  
Soft-Start and Shutdown**

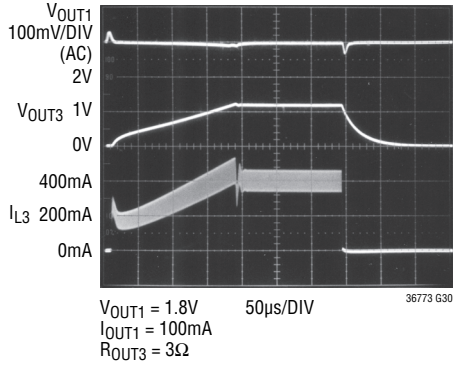

**OVP Connection Waveform**

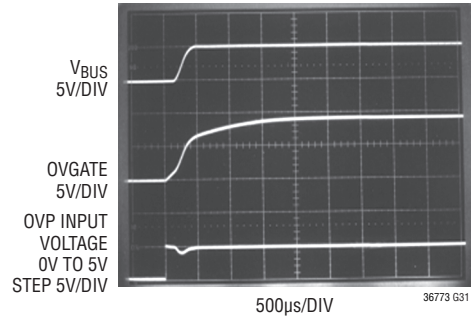

**OVP Protection Waveform**

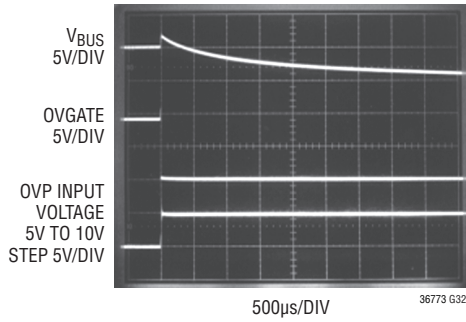

**OVP Reconnection Waveform**

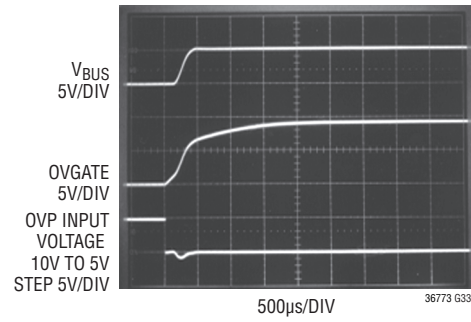

**OVSENS Quiescent Current  
vs Temperature**

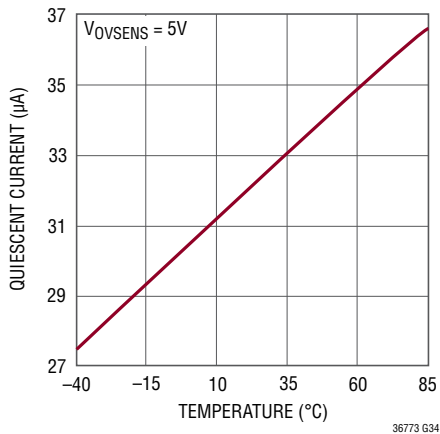

**Rising Overvoltage Threshold  
vs Temperature**

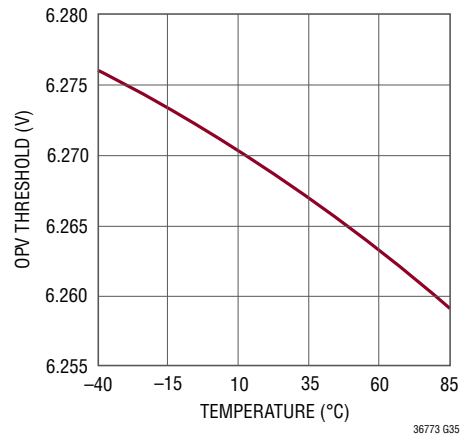

## TYPICAL PERFORMANCE CHARACTERISTICS $T_J = 25^\circ\text{C}$ unless otherwise specified

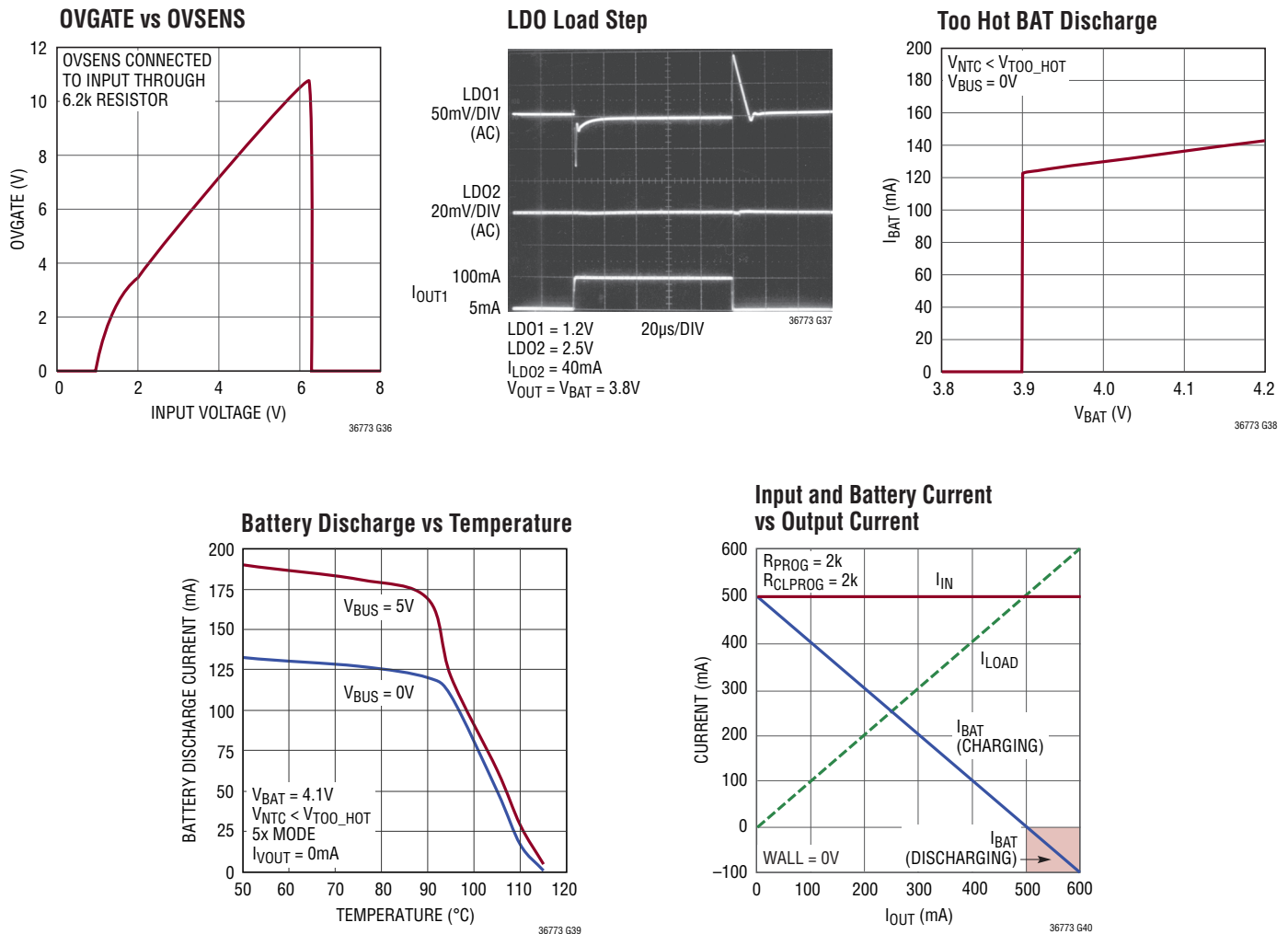

## PIN FUNCTIONS

**I<sub>LIM0</sub>, I<sub>LIM1</sub> (Pins 1, 2):** Input Current Control Pins. I<sub>LIM0</sub> and I<sub>LIM1</sub> control the input current limit. See Table 1 in the USB PowerPath Controller section. Both pins are pulled low by a weak current sink.

**NC (Pins 3, 9, 18, 19, 20, 22):** No Connect. This pin has no function and may be floated or connected to ground.

**WALL (Pin 4):** Wall Adapter Present Input. Pulling this pin above 4.3V will disconnect the power path from V<sub>BUS</sub> to V<sub>OUT</sub>. The  $\overline{\text{ACPR}}$  pin will also be pulled low to indicate that a wall adapter has been detected.

**SW3 (Pin 5):** Power Transmission (Switch) Pin for Step-Down Switching Regulator 3 (Buck3).

**V<sub>IN3</sub> (Pin 6):** Power Input for Step-Down Switching Regulator 3. This pin should be connected to V<sub>OUT</sub>.

**FB3 (Pin 7):** Feedback Input for Step-Down Switching Regulator 3 (Buck3). This pin serves to a fixed voltage of 0.8V when the control loop is complete.

**OVSENSE (Pin 8):** Overvoltage Protection Sense Input. OVSENSE should be connected through a 6.2k resistor to the input power connector and the drain of an external

36773f



## PIN FUNCTIONS

N-channel MOSFET pass transistor. When the voltage on this pin exceeds a preset level, the OVGATE pin will be pulled to GND to disable the pass transistor and protect downstream circuitry.

**DV<sub>CC</sub> (Pin 10):** Supply Voltage for I<sup>2</sup>C Lines. This pin sets the logic reference level of the LTC3677-3. A UVLO circuit on the DV<sub>CC</sub> pin forces all registers to all 0s whenever DV<sub>CC</sub> is <1V. Bypass to GND with a 0.1μF capacitor.

**SDA (Pin 11):** I<sup>2</sup>C Data Input. Serial data is shifted one bit per clock to control the LTC3677-3. The logic level for SDA is referenced to DV<sub>CC</sub>.

**SCL (Pin 12):** I<sup>2</sup>C Clock Input. The logic level for SCL is referenced to DV<sub>CC</sub>.

**OVGATE (Pin 13):** Overvoltage Protection Gate Output. Connect OVGATE to the gate pin of an external N-channel MOSFET pass transistor. The source of the transistor should be connected to V<sub>BUS</sub> and the drain should be connected to the product's DC input connector. In the absence of an overvoltage condition, this pin is connected to an internal charge pump capable of creating sufficient overdrive to fully enhance this transistor. If an overvoltage condition is detected, OVGATE is brought rapidly to GND to prevent damage. OVGATE works in conjunction with OVSENSE to provide this protection.

**PWR\_ON (Pin 14):** Logic Input Used to Keep Buck1, Buck2 and LDO2 Enabled After Power-Up. May also be used to enable regulators directly (sequence = LDO2 → Buck1 → Buck2). See the Pushbutton Interface Operation section for more information.

**$\overline{\text{ON}}$  (Pin 15):** Pushbutton Input. A weak internal pull-up forces  $\overline{\text{ON}}$  high when left floating. A normally open pushbutton is connected from  $\overline{\text{ON}}$  to ground to force a low state on this pin.

**PBSTAT (Pin 16):** Open-drain output is a debounced and buffered version of  $\overline{\text{ON}}$  to be used for processor interrupts.

**EN3 (Pin 17):** Enable Pin for Step-Down Switching Regulator 3 (Buck3).

**PGOOD (Pin 21):** Open-Drain Output. PGOOD indicates that Buck1, Buck2 and LDO1 are within 8% of final regulation

value. There is a 230ms delay from all regulators reaching regulation and PGOOD going high.

**LDO1\_FB (Pin 23):** Feedback Voltage Input for Low Dropout Linear Regulator 1 (LDO1). LDO1 output voltage is set using an external resistor divider between LDO1 and LDO1\_FB.

**LDO2\_FB (Pin 24):** Feedback Voltage Input for Low Dropout Linear Regulator 2 (LDO2). LDO2 output voltage is set using an external resistor divider between LDO2 and LDO2\_FB.

**FB2 (Pin 25):** Feedback Input for Step-Down Switching Regulator 2 (Buck2). This pin serves to a fixed voltage of 0.8V when the control loop is complete.

**FB1 (Pin 26):** Feedback Input for Step-Down Switching Regulator 1 (Buck1). This pin serves to a fixed voltage of 0.8V when the control loop is complete.

**V<sub>INLDO1</sub> (Pin 27):** Input Supply of Low Dropout Linear Regulator 1 (LDO1). This pin should be bypassed to ground with a 1μF or greater ceramic capacitor.

**LDO1 (Pin 28):** Output of Low Dropout Linear Regulator 1. LDO1 is an always-on LDO and will be enabled whenever the part is not in V<sub>OUT</sub> UVLO. This pin must be bypassed to ground with a 1μF or greater ceramic capacitor.

**LDO2 (Pin 29):** Output of Low Dropout Linear Regulator 2. This pin must be bypassed to ground with a 1μF or greater ceramic capacitor.

**V<sub>INLDO2</sub> (Pin 30):** Input Supply of Low Dropout Linear Regulator 2 (LDO2). This pin should be bypassed to ground with a 1μF or greater ceramic capacitor.

**SW2 (Pin 31):** Power Transmission (Switch) Pin for Step-Down Switching Regulator 2 (Buck2).

**V<sub>IN12</sub> (Pin 32):** Power Input for Step-Down Switching Regulators 1 and 2. This pin will generally be connected to V<sub>OUT</sub>.

**SW1 (Pin 33):** Power Transmission (Switch) Pin for Step-Down Switching Regulator 1 (Buck1).

**NTCBIAS (Pin 34):** Output Bias Voltage for NTC. A resistor from this pin to the NTC pin will bias the NTC thermistor.



## PIN FUNCTIONS

**NTC (Pin 35):** The NTC pin connects to a battery's thermistor to determine if the battery is too hot or too cold to charge. If the battery's temperature is out of range, charging is paused until it drops back into range. A low drift bias resistor is required from NTCBIAS to NTC and a thermistor is required from NTC to ground.

**PROG (Pin 36):** Charge Current Program and Charge Current Monitor Pin. Connecting a resistor from PROG to ground programs the charge current:

$$I_{\text{CHG}} = \frac{1000\text{V}}{R_{\text{PROG}}} \text{ (A)}$$

If sufficient input power is available in constant-current mode, this pin servos to 1V. The voltage on this pin always represents the actual charge current.

**IDGATE (Pin 37):** Ideal Diode Gate Connection. This pin controls the gate of an optional external P-channel MOSFET transistor used to supplement the internal ideal diode. The source of the P-channel MOSFET should be connected to  $V_{\text{OUT}}$  and the drain should be connected to BAT. It is important to maintain high impedance on this pin and minimize all leakage paths.

**BAT (Pin 38):** Single-Cell Li-Ion Battery Pin. Depending on available power and load, a Li-Ion battery on BAT will either deliver system power to  $V_{\text{OUT}}$  through the ideal diode or be charged from the battery charger.

**$V_{\text{OUT}}$  (Pin 39):** Output Voltage of the PowerPath Controller and Input Voltage of the Battery Charger. The majority of the portable product should be powered from  $V_{\text{OUT}}$ . The LTC3677-3 will partition the available power between the external load on  $V_{\text{OUT}}$  and the internal battery charger. Priority is given to the external load and any extra power is used to charge the battery. An ideal diode from BAT to  $V_{\text{OUT}}$  ensures that  $V_{\text{OUT}}$  is powered even if the load exceeds the allotted input current from  $V_{\text{BUS}}$  or if the  $V_{\text{BUS}}$  power source is removed.  $V_{\text{OUT}}$  should be bypassed with a low impedance multilayer ceramic capacitor.

**$V_{\text{BUS}}$  (Pin 40):** USB Input Voltage.  $V_{\text{BUS}}$  will usually be connected to the USB port of a computer or a DC output

wall adapter.  $V_{\text{BUS}}$  should be bypassed with a low impedance multilayer ceramic capacitor.

**ACPR (Pin 41):** Wall Adapter Present Output (Active Low). A low on this pin indicates that the wall adapter input comparator has had its input pulled above its input threshold (typically 4.3V). This pin can be used to drive the gate of an external P-channel MOSFET to provide power to  $V_{\text{OUT}}$  from a power source other than a USB port.

**EXTPWR (Pin 42):** External Power Present Output (Active Low, Open-Drain Output). A low on this pin indicates that external power is present at either the  $V_{\text{BUS}}$  or WALL input. For  $\overline{\text{EXTPWR}}$  to signal  $V_{\text{BUS}}$  present,  $V_{\text{BUS}}$  must exceed the  $V_{\text{BUS}}$  undervoltage lockout threshold. For  $\overline{\text{EXTPWR}}$  to signal WALL present, WALL must exceed the absolute and differential WALL input thresholds. The  $\overline{\text{EXTPWR}}$  signal is independent of the  $I_{\text{LIM1}}$  and  $I_{\text{LIM0}}$  pins. Thus, it is possible to have the input current limit circuitry in suspend with  $\overline{\text{EXTPWR}}$  showing a valid charging level on  $V_{\text{BUS}}$ .

**CLPROG (Pin 43):** Input Current Program and Input Current Monitor Pin. A resistor from CLPROG to ground determines the upper limit of the current drawn from the  $V_{\text{BUS}}$  pin (i.e., the input current limit). A precise fraction of the input current,  $h_{\text{CLPROG}}$ , is sent to the CLPROG pin. The input PowerPath delivers current until the CLPROG pin reaches 2V (10x mode), 1V (5x mode) or 0.2V (1x mode). Therefore, the current drawn from  $V_{\text{BUS}}$  will be limited to an amount given by  $h_{\text{CLPROG}}$  and  $R_{\text{CLPROG}}$ . In USB applications the resistor  $R_{\text{CLPROG}}$  should be set to no less than 2.1k.

**CHRG (Pin 44):** Open-Drain Charge Status Output. The  $\overline{\text{CHRG}}$  pin indicates the status of the battery charger. If  $\overline{\text{CHRG}}$  is high then the charger is near the float voltage (charge current less than 1/10th programmed charge current) or charging is complete and charger is disabled. A low on  $\overline{\text{CHRG}}$  indicates that the charger is enabled. For more information see the Charge Status Indication section.

**GND (Exposed Pad Pin 45):** The exposed package pad is ground and must be soldered to PCB ground for electrical contact and rated thermal performance.

**BLOCK DIAGRAM**

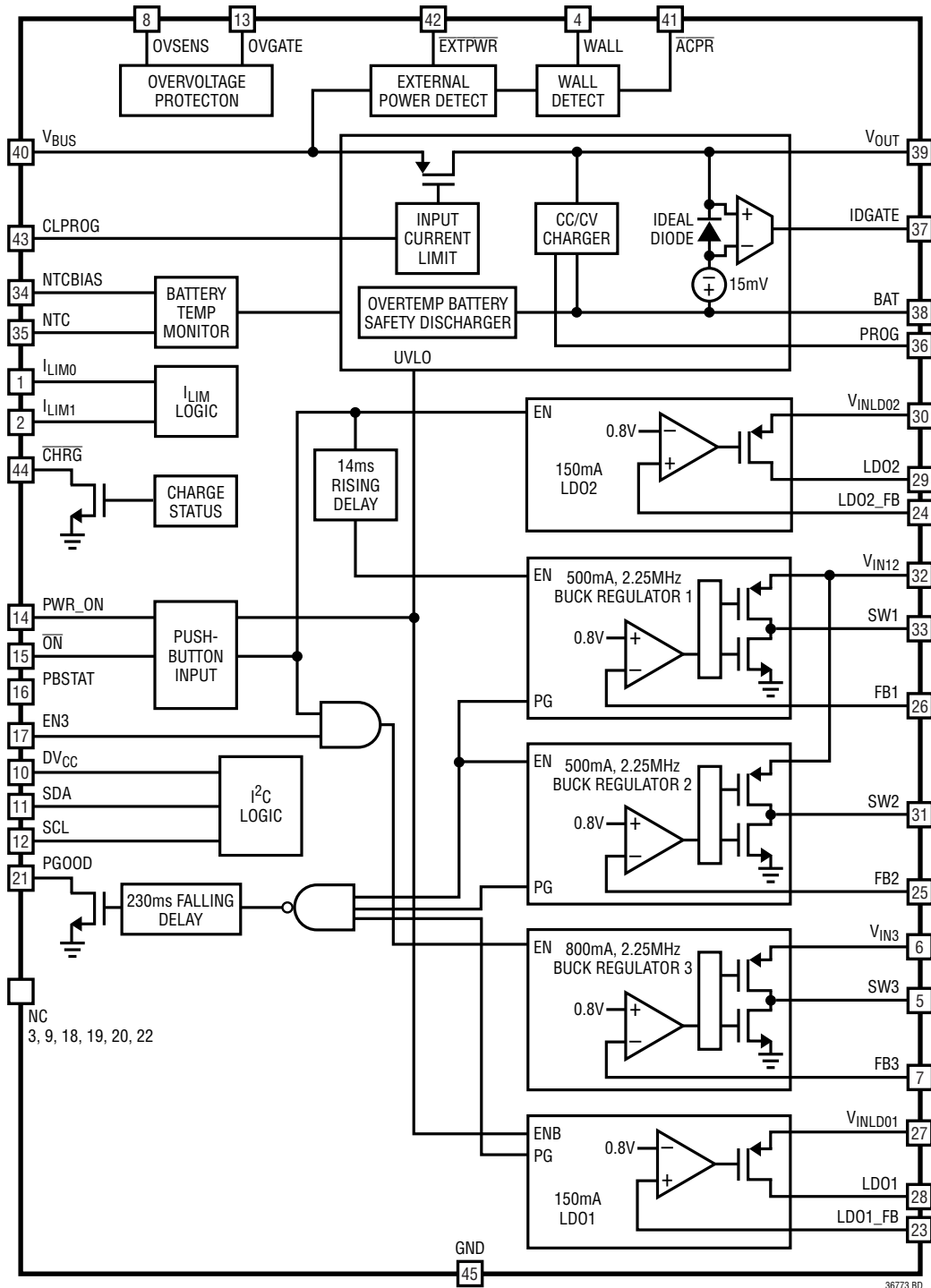

36773 BD

## OPERATION

### PowerPath OPERATION

#### Introduction

The LTC3677-3 is highly integrated power management IC that includes the following features:

- PowerPath controller
- Battery charger
- Ideal diode
- Input overvoltage protection
- Pushbutton controller
- Three step-down switching regulators
- Two low dropout linear regulators

Designed specifically for USB applications, the PowerPath controller incorporates a precision input current limit which communicates with the battery charger to ensure that input current does not violate the USB average input current specification. The ideal diode from BAT to  $V_{OUT}$

guarantees that ample power is always available to  $V_{OUT}$  even if there is insufficient or absent power at  $V_{BUS}$ . The LTC3677-3 also has the ability to receive power from a wall adapter or other non-current-limited power source. Such a power supply can be connected to the  $V_{OUT}$  pin of the LTC3677-3 through an external device such as a power Schottky or FET, as shown in Figure 1. The LTC3677-3 has the unique ability to use the output, which is powered by an external supply, to charge the battery while providing power to the load. A comparator on the WALL pin is configured to detect the presence of the wall adapter and shut off the connection to the USB. This prevents reverse conduction from  $V_{OUT}$  to  $V_{BUS}$  when a wall adapter is present.

The LTC3677-3 also includes a pushbutton input to control the power sequencing of two synchronous step-down switching regulators (Buck1 and Buck2), a low dropout regulator (LDO2) and system reset. The three 2.25MHz constant-frequency current mode step-down switching regulators provide 500mA, 500mA and 800mA each and

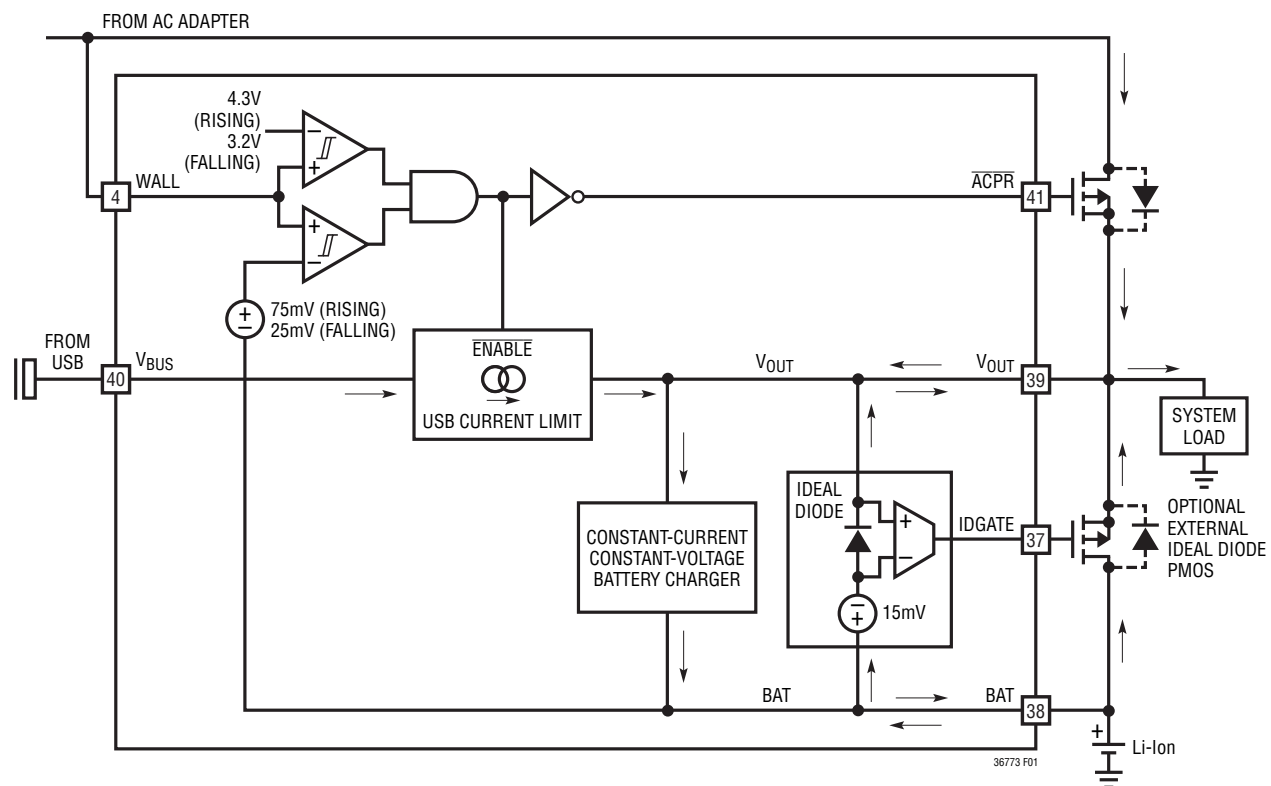

Figure 1. Simplified PowerPath Block Diagram

## OPERATION

support 100% duty cycle operation as well as operating in Burst Mode operation for high efficiency at light load. No external compensation components are required for the switching regulators. The two low dropout regulators can output up to 150mA.

All regulators can be programmed for a minimum output voltage of 0.8V and can be used to power a microcontroller core, microcontroller I/O, memory or other logic circuitry.

### USB PowerPath Controller

The input current limit and charge control circuits of the LTC3677-3 is designed to limit input current as well as control battery charge current as a function of  $I_{V_{OUT}}$ .  $V_{OUT}$  drives the combination of the external load, the three step-down switching regulators, two LDOs and the battery charger.

If the combined load does not exceed the programmed input current limit,  $V_{OUT}$  will be connected to  $V_{BUS}$  through an internal 200mΩ P-channel MOSFET. If the combined load at  $V_{OUT}$  exceeds the programmed input current limit, the battery charger will reduce its charge current by the amount necessary to enable the external load to be satisfied while maintaining the programmed input current. Even if the battery charge current is set to exceed the allowable USB current, the average input current USB specification will not be violated. Furthermore, load current at  $V_{OUT}$  will always be prioritized and only excess available current will be used to charge the battery. The current out of the CLPROG pin is a fraction ( $1/h_{CLPROG}$ ) of the  $V_{BUS}$  current. When a programming resistor is connected from CLPROG to GND, the voltage on CLPROG represents the input current:

$$I_{V_{BUS}} = I_{BUSQ} + \frac{V_{CLPROG}}{R_{CLPROG}} \cdot h_{CLPROG}$$

where  $I_{BUSQ}$  and  $h_{CLPROG}$  are given in the Electrical Characteristics table.

The input current limit is programmed by the  $I_{LIM0}$  and  $I_{LIM1}$  pins. The LTC3677-3 can be configured to limit input current to one of several possible settings as well as be deactivated (USB suspend). The input current limit will be set by the appropriate servo voltage and the resistor on CLPROG according to the following expression:

$$I_{V_{BUS}} = I_{BUSQ} + \frac{0.2V}{R_{CLPROG}} \cdot h_{CLPROG} \text{ (1x Mode)}$$

$$I_{V_{BUS}} = I_{BUSQ} + \frac{1V}{R_{CLPROG}} \cdot h_{CLPROG} \text{ (5x Mode)}$$

$$I_{V_{BUS}} = I_{BUSQ} + \frac{2V}{R_{CLPROG}} \cdot h_{CLPROG} \text{ (10x Mode)}$$

Under worst-case conditions, the USB specification for average input current will not be violated with an  $R_{CLPROG}$  resistor of 2.1k or greater. Table 1 shows the available settings for the  $I_{LIM0}$  and  $I_{LIM1}$  pins:

**Table 1. Controlled Input Current Limit**

$I_{LIM1}$	$I_{LIM0}$	$I_{BUS(LIM)}$
1	1	100mA (1x)
1	0	1A (10x)
0	1	Suspend
0	0	500mA (5x)

Notice that when  $I_{LIM0}$  is low and  $I_{LIM1}$  is high, the input current limit is set to a higher current limit for increased charging and current availability at  $V_{OUT}$ . This mode is typically used when there is a higher power, non-USB source available at the  $V_{BUS}$  pin.

## OPERATION

### Ideal Diode from BAT to $V_{OUT}$

The LTC3677-3 has an internal ideal diode as well as a controller for an optional external ideal diode. Both the internal and the external ideal diodes respond quickly whenever  $V_{OUT}$  drops below BAT. If the load increases beyond the input current limit, additional current will be pulled from the battery via the ideal diodes. Furthermore, if power to  $V_{BUS}$  (USB) or  $V_{OUT}$  (external wall power or high voltage regulator) is removed, then all of the application power will be provided by the battery via the ideal diodes. The ideal diodes are fast enough to keep  $V_{OUT}$  from dropping significantly below  $V_{BAT}$  with just the recommended output capacitor (see Figure 2). The ideal diode consists of a precision amplifier that enables an on-chip P-channel MOSFET whenever the voltage at  $V_{OUT}$  is approximately 15mV ( $V_{FWD}$ ) below the voltage at BAT. The resistance of the internal ideal diode is approximately 200m $\Omega$ . If this is sufficient for the application, then no external components are necessary. However, if lower resistance is needed, an external P-channel MOSFET can be added from BAT to  $V_{OUT}$ . The IDGATE pin of the LTC3677-3 drives the gate of the external P-channel MOSFET for automatic ideal diode control. The source of the MOSFET should be connected to  $V_{OUT}$  and the drain should be connected to BAT. Capable of driving a 1nF load, the IDGATE pin can control an external P-channel MOSFET having extremely low on-resistance.

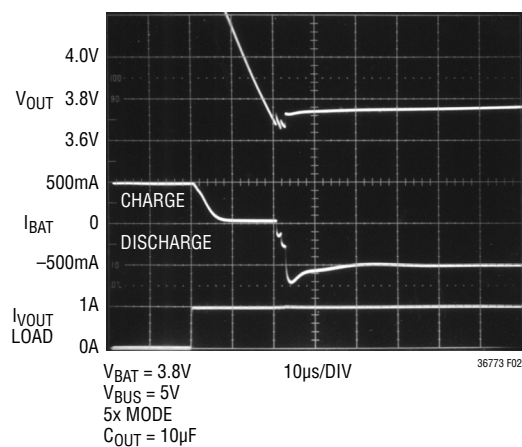

Figure 2. Ideal Diode Transient Response

### Using the WALL Pin to Detect the Presence of an External Power Source

The WALL input pin can be used to identify the presence of an external power source (particularly one that is not subject to a fixed current limit like the USB  $V_{BUS}$  input). Typically, such a power supply would be a 5V wall adapter output or the low voltage output of a high voltage buck regulator. When the wall adapter output (or buck regulator output) is connected directly to the WALL pin, and the voltage exceeds the WALL pin threshold, the USB power path (from  $V_{BUS}$  to  $V_{OUT}$ ) will be disconnected. Furthermore, the  $\overline{ACPR}$  pin will be pulled low. In order for the presence of an external power supply to be acknowledged, both of the following conditions must be satisfied:

1. The WALL pin voltage must exceed approximately 4.3V.
2. The WALL pin voltage must be greater than 75mV above the BAT pin voltage.

The input power path (between  $V_{BUS}$  and  $V_{OUT}$ ) is re-enabled and the  $\overline{ACPR}$  pin is pulled high when either of the following conditions is met:

1. The WALL pin voltage falls to within 25mV of the BAT pin voltage.
2. The WALL pin voltage falls below 3.2V.

Each of these thresholds is suitably filtered in time to prevent transient glitches on the WALL pin from falsely triggering an event.

### Suspend Mode

When  $I_{LIM0}$  is pulled high and  $I_{LIM1}$  is pulled low the LTC3677-3 enters suspend mode to comply with the USB specification. In this mode, the power path between  $V_{BUS}$  and  $V_{OUT}$  is put in a high impedance state to reduce the  $V_{BUS}$  input current to 50 $\mu$ A. If no other power source is available to drive WALL and  $V_{OUT}$ , the system load connected to  $V_{OUT}$  is supplied through the ideal diodes connected to BAT.

## OPERATION

### $V_{BUS}$ Undervoltage Lockout (UVLO) and Undervoltage Current Limit (UVCL)

An internal undervoltage lockout circuit monitors  $V_{BUS}$  and keeps the input current limit circuitry off until  $V_{BUS}$  rises above the rising UVLO threshold (3.8V) and at least 50mV above  $V_{OUT}$ . Hysteresis on the UVLO turns off the input current limit if  $V_{BUS}$  drops below 3.7V or 50mV below  $V_{OUT}$ . When this happens, system power at  $V_{OUT}$  will be drawn from the battery via the ideal diode. To minimize the possibility of oscillation in and out of UVLO when using resistive input supplies, the input current limit is reduced as  $V_{BUS}$  falls below 4.45V (typ).

### Battery Charger

The LTC3677-3 includes a constant-current/constant-voltage battery charger with automatic recharge, automatic termination by safety timer, low voltage trickle charging, bad cell detection and thermistor sensor input for out of temperature charge pausing. When a battery charge cycle begins, the battery charger first determines if the battery is deeply discharged. If the battery voltage is below  $V_{TRKL}$ , typically 2.85V, an automatic trickle charge feature sets the battery charge current to 10% of the programmed value. If the low voltage persists for more than 1/2 hour, the battery charger automatically terminates. Once the battery voltage is above 2.85V, the battery charger begins charging in full power constant-current mode. The current delivered to the battery will try to reach  $1000V/R_{PROG}$ . Depending on available input power and external load conditions, the battery charger may or may not be able to charge at the full programmed rate. The external load will always be prioritized over the battery charge current. The USB current limit programming will always be observed and only additional current will be available to charge the battery. When system loads are light, battery charge current will be maximized.

### Charge Termination

The battery charger has a built-in safety timer. When the battery voltage approaches the float voltage, the charge current begins to decrease as the LTC3677-3 enters constant-voltage mode. Once the battery charger detects that it has entered constant-voltage mode, the four hour safety timer is started. After the safety timer expires, charging of the battery will terminate and no more current will be delivered.

### Automatic Recharge

After the battery charger terminates, it will remain off drawing only microamperes of current from the battery. If the portable product remains in this state long enough, the battery will eventually self discharge. To ensure that the battery is always topped off, a charge cycle will automatically begin when the battery voltage falls below  $V_{RECHRG}$  (typically 4.1V for LTC3677-3). In the event that the safety timer is running when the battery voltage falls below  $V_{RECHRG}$ , the timer will reset back to zero. To prevent brief excursions below  $V_{RECHRG}$  from resetting the safety timer, the battery voltage must be below  $V_{RECHRG}$  for more than 1.3ms. The charge cycle and safety timer will also restart if the  $V_{BUS}$  UVLO cycles low and then high (e.g.,  $V_{BUS}$  is removed and then replaced).

### Charge Current

The charge current is programmed using a single resistor from PROG to ground. 1/1000th of the battery charge current is delivered to PROG which will attempt to servo to 1.000V. Thus, the battery charge current will try to reach 1000 times the current in the PROG pin. The program resistor and the charge current are calculated using the following equations:

$$R_{PROG} = \frac{1000V}{I_{CHG}}, \quad I_{CHG} = \frac{1000V}{R_{PROG}}$$



## OPERATION

In either the constant-current or constant-voltage charging modes, the PROG pin voltage will be proportional to the actual charge current delivered to the battery. Therefore, the actual charge current can be determined at any time by monitoring the PROG pin voltage and using the following equation:

$$I_{\text{BAT}} = \frac{V_{\text{PROG}}}{R_{\text{PROG}}} \cdot 1000$$

In many cases, the actual battery charge current,  $I_{\text{BAT}}$ , will be lower than  $I_{\text{CHG}}$  due to limited input current available and prioritization with the system load drawn from  $V_{\text{OUT}}$ .

### Thermal Regulation

To prevent thermal damage to the IC or surrounding components, an internal thermal feedback loop will automatically decrease the programmed charge current if the die temperature rises to approximately 110°C. Thermal regulation protects the LTC3677-3 from excessive temperature due to high power operation or high ambient thermal conditions and allows the user to push the limits of the power handling capability with a given circuit board design without risk of damaging the LTC3677-3 or external components. The benefit of the LTC3677-3 thermal regulation loop is that charge current can be set according to actual conditions rather than worst-case conditions with the assurance that the battery charger will automatically reduce the current in worst-case conditions.

### Charge Status Indication

The  $\overline{\text{CHRG}}$  pin indicates the status of the battery charger. An open-drain output, the  $\overline{\text{CHRG}}$  pin can drive an indicator LED through a current limiting resistor for human interfacing or simply a pull-up resistor for microprocessor interfacing. When charging begins,  $\overline{\text{CHRG}}$  is pulled low and remains low for the duration of a normal charge cycle. When charging is complete, i.e., the charger enters constant-voltage mode and the charge current has dropped to one-tenth of the programmed value, the  $\overline{\text{CHRG}}$  pin is released (high impedance). The  $\overline{\text{CHRG}}$  pin does not respond to the C/10 threshold if the LTC3677-3 is in input current limit. This prevents false end-of-charge indications due to insufficient power available to the battery

charger. Even though charging is stopped during an NTC fault the  $\overline{\text{CHRG}}$  pin will stay low indicating that charging is not complete.

### Battery Charger Stability Considerations

The LTC3677-3's battery charger contains both a constant-voltage and a constant-current control loop. The constant-voltage loop is stable without any compensation when a battery is connected with low impedance leads. Excessive lead length, however, may add enough series inductance to require a bypass capacitor of at least 1 $\mu$ F from BAT to GND. Furthermore, a 4.7 $\mu$ F capacitor in series with a 0.2 $\Omega$  to 1 $\Omega$  resistor from BAT to GND is required to keep ripple voltage low when the battery is disconnected.

High value, low ESR multilayer ceramic chip capacitors reduce the constant-voltage loop phase margin, possibly resulting in instability. Ceramic capacitors up to 22 $\mu$ F may be used in parallel with a battery, but larger ceramics should be decoupled with 0.2 $\Omega$  to 1 $\Omega$  of series resistance.

In constant-current mode, the PROG pin is in the feedback loop rather than the battery voltage. Because of the additional pole created by any PROG pin capacitance, capacitance on this pin must be kept to a minimum. With no additional capacitance on the PROG pin, the battery charger is stable with program resistor values as high as 25k. However, additional capacitance on this node reduces the maximum allowed program resistor. The pole frequency at the PROG pin should be kept above 100kHz. Therefore, if the PROG pin has a parasitic capacitance,  $C_{\text{PROG}}$ , the following equation should be used to calculate the maximum resistance value for  $R_{\text{PROG}}$ :

$$R_{\text{PROG}} \leq \frac{1}{2\pi \cdot 100\text{kHz} \cdot C_{\text{PROG}}}$$

### NTC Thermistor and Battery Voltage Reduction

The battery temperature is measured by placing a negative temperature coefficient (NTC) thermistor close to the battery pack. To use this feature connect the NTC thermistor,  $R_{\text{NTC}}$ , between the NTC pin and ground and a bias resistor,  $R_{\text{NOM}}$ , from NTCBIAS to NTC.  $R_{\text{NOM}}$  should be a 1% resistor with a value equal to the value of the chosen NTC thermistor at 25°C (R25). The LTC3677-3 will

## OPERATION

pause charging when the resistance of the NTC thermistor drops to 0.54 times the value of R25 or approximately 54k (for a Vishay curve 1 thermistor, this corresponds to approximately 40°C). If the battery charger is in constant-voltage (float) mode, the safety timer also pauses until the thermistor indicates a return to a valid temperature. As the temperature drops, the resistance of the NTC thermistor rises. The LTC3677-3 is also designed to pause charging when the value of the NTC thermistor increases to 3.25 times the value of R25. For a Vishay curve 1 thermistor this resistance, 325k, corresponds to approximately 0°C. The hot and cold comparators each have approximately 3°C of hysteresis to prevent oscillation about the trip point. The typical NTC circuit is shown in Figure 3.

To improve safety and reliability the battery voltage is reduced when the battery temperature becomes excessively high. When the resistance of the NTC thermistor drops to about 0.35 times the value of R25 or approximately 35k (for a Vishay curve 1 thermistor, this corresponds to approximately 50°C) the NTC enables circuitry to monitor the battery voltage. If the battery voltage is above the battery discharge threshold (about 3.9V) then the battery discharge circuitry is enabled and draws about 140mA from the battery when  $V_{BUS} = 0V$  and about 180mA when  $V_{BUS} = 5V$ . The battery discharge current is disabled below the battery discharge threshold.

When the charger is disabled an internal watchdog timer samples the NTC thermistor for about 150µs every 150ms and will enable the battery monitoring circuitry if the battery temperature exceeds the NTC TOO\_HOT threshold. If adding a capacitor to the NTC pin for filtering the time constant must be much less than 150µs so that the NTC pin can settle to its final value during the sampling period. A time constant less than 10µs is recommended. Once the battery monitoring circuitry is enabled it will remain enabled and monitoring the battery voltage until the battery temperature falls back below the discharge temperature threshold. The battery discharge circuitry is only enabled if the battery voltage is greater than the battery discharge threshold.

### Alternate NTC Thermistors and Biasing

The LTC3677-3 provides temperature qualified charging if a grounded thermistor and a bias resistor are connected to NTC. By using a bias resistor whose value is equal to the room temperature resistance of the thermistor (R25) the upper and lower temperatures are pre-programmed to approximately 40°C and 0°C, respectively (assuming a Vishay curve 1 thermistor).

The upper and lower temperature thresholds can be adjusted by either a modification of the bias resistor value

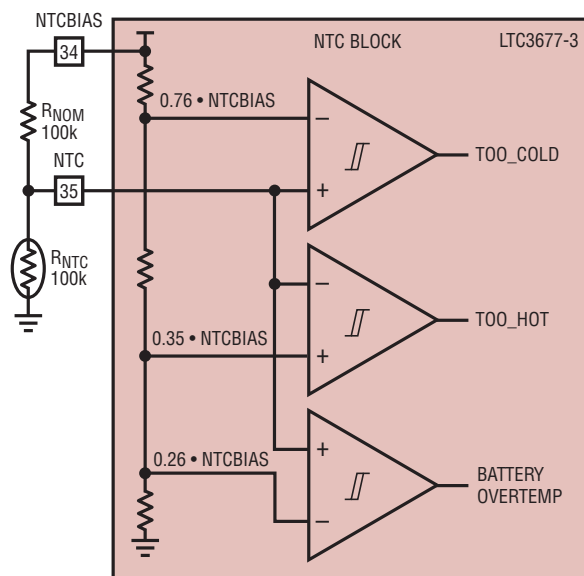

Figure 3. Typical NTC Thermistor Circuit



## OPERATION

or by adding a second adjustment resistor to the circuit. If only the bias resistor is adjusted, then either the upper or the lower threshold can be modified but not both. The other trip point will be determined by the characteristics of the thermistor. Using the bias resistor in addition to an adjustment resistor, both the upper and the lower temperature trip points can be independently programmed with the constraint that the difference between the upper and lower temperature thresholds cannot decrease. Examples of each technique are given below.

NTC thermistors have temperature characteristics which are indicated on resistance-temperature conversion tables. The Vishay-Dale thermistor NTHS0603N011-N1003F, used in the following examples, has a nominal value of 100k and follows the Vishay curve 1 resistance-temperature characteristic.

In the explanation below, the following notation is used.

$R_{25}$  = Value of the thermistor at 25°C

$R_{NTC|COLD}$  = Value of thermistor at the cold trip point

$R_{NTC|HOT}$  = Value of the thermistor at the hot trip point

$r_{COLD}$  = Ratio of  $R_{NTC|COLD}$  to  $R_{25}$

$r_{HOT}$  = Ratio of  $R_{NTC|HOT}$  to  $R_{25}$

$R_{NOM}$  = Primary thermistor bias resistor (see Figure 3)

$R_1$  = Optional temperature range adjustment resistor (see Figure 4)

The trip points for the LTC3677-3's temperature qualification are internally programmed at  $0.35 \cdot V_{NTC}$  for the hot threshold and  $0.76 \cdot V_{NTC}$  for the cold threshold.

Therefore, the hot trip point is set when:

$$\frac{R_{NTC|HOT}}{R_{NOM} + R_{NTC|HOT}} \cdot NTCBIAS = 0.35 \cdot NTCBIAS$$

and the cold trip point is set when:

$$\frac{R_{NTC|COLD}}{R_{NOM} + R_{NTC|COLD}} \cdot NTCBIAS = 0.76 \cdot NTCBIAS$$

Solving these equations for  $R_{NTC|COLD}$  and  $R_{NTC|HOT}$  results in the following:

$$R_{NTC|HOT} = 0.538 \cdot R_{NOM}$$

and

$$R_{NTC|COLD} = 3.17 \cdot R_{NOM}$$

By setting  $R_{NOM}$  equal to  $R_{25}$ , the above equations result in  $r_{HOT} = 0.538$  and  $r_{COLD} = 3.17$ . Referencing these ratios to the Vishay resistance-temperature curve 1 chart gives a hot trip point of about 40°C and a cold trip point of about 0°C. The difference between the hot and cold trip points is approximately 40°C.

By using a bias resistor,  $R_{NOM}$ , different in value from  $R_{25}$ , the hot and cold trip points can be moved in either direction. The temperature span will change somewhat due to the nonlinear behavior of the thermistor. The following equations can be used to easily calculate a new value for the bias resistor:

$$R_{NOM} = \frac{r_{HOT}}{0.538} \cdot R_{25}$$

$$R_{NOM} = \frac{r_{COLD}}{3.17} \cdot R_{25}$$

where  $r_{HOT}$  and  $r_{COLD}$  are the resistance ratios at the *desired* hot and cold trip points. Note that these equations

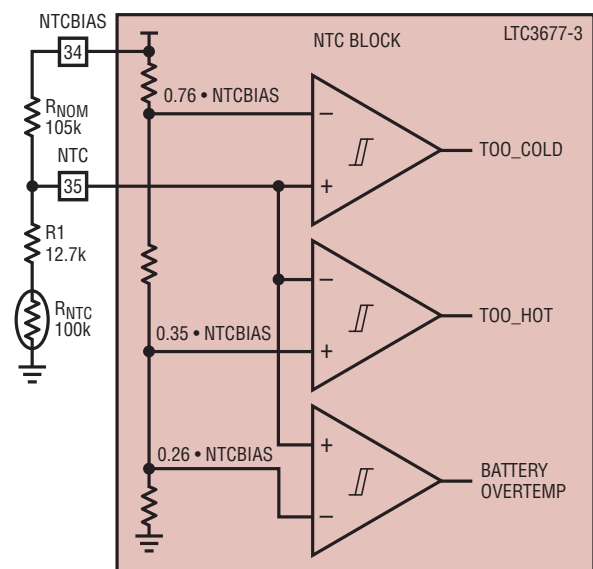

Figure 4. NTC Thermistor Circuit with Additional Bias Resistor

## OPERATION

are linked. Therefore, only one of the two trip points can be chosen, the other is determined by the default ratios designed in the IC.

Consider an example where a 60°C hot trip point is desired. From the Vishay curve 1 R-T characteristics,  $r_{HOT}$  is 0.2488 at 60°C. Using the above equation,  $R_{NOM}$  should be set to 46.4k. With this value of  $R_{NOM}$ , the cold trip point is about 16°C. Notice that the span is now 44°C rather than the previous 40°C. This is due to the decrease in temperature gain of the thermistor as absolute temperature increases.

The upper and lower temperature trip points can be independently programmed by using an additional bias resistor as shown in Figure 4. The following formulas can be used to compute the values of  $R_{NOM}$  and R1:

$$R_{NOM} = \frac{r_{COLD} - r_{HOT}}{2.714} \cdot R25$$

$$R1 = 0.536 \cdot R_{NOM} - r_{HOT} \cdot R25$$

For example, to set the trip points to 0°C and 45°C with a Vishay curve 1 thermistor choose:

$$R_{NOM} = \frac{3.266 - 0.4368}{2.714} \cdot 100k = 104.2k$$

the nearest 1% value is 105k.

$$R1 = 0.536 \cdot 105k - 0.4368 \cdot 100k = 12.6k$$

the nearest 1% value is 12.7k. The final solution is shown in Figure 4 and results in an upper trip point of 45°C and a lower trip point of 0°C.

### Overvoltage Protection (OVP)

The LTC3677-3 can protect itself from the inadvertent application of excessive voltage to  $V_{BUS}$  or WALL with just two external components: an N-channel MOSFET and a 6.2k resistor. The maximum safe overvoltage magnitude will be determined by the choice of the external N-channel MOSFET and its associated drain breakdown voltage.

The overvoltage protection module consists of two pins. The first, OVSENS, is used to measure the externally applied voltage through an external resistor. The second, OVGATE, is an output used to drive the gate pin of an external FET. The voltage at OVSENS will be lower than the OVP input voltage by  $(I_{OVSENS} \cdot 6.2k\Omega)$  due to the OVP circuit's quiescent current. The OVP input will be 200mV to 400mV higher than OVSENS under normal operating conditions. When OVSENS is below 6V, an internal charge pump will drive OVGATE to approximately  $1.88 \cdot OVSENS$ . This will enhance the N-channel MOSFET and provide a low impedance connection to  $V_{BUS}$  or WALL which will, in turn, power the LTC3677-3. If OVSENS should rise above 6V (6.35V OVP input) due to a fault or use of an incorrect wall adapter, OVGATE will be pulled to GND, disabling the external FET to protect downstream circuitry. When the voltage drops below 6V again, the external FET will be re-enabled.

In an overvoltage condition, the OVSENS pin will be clamped at 6V. The external 6.2k resistor must be sized appropriately to dissipate the resultant power. For example, a 1/10W 6.2k resistor can have at most  $\sqrt{P_{MAX} \cdot 6.2k} = 24V$  applied across its terminals. With the 6V at OVSENS, the maximum overvoltage magnitude that this resistor can withstand is 30V. A 1/4W 6.2k resistor raises this value to 45V.

The charge pump output on OVGATE has limited output drive capability. Care must be taken to avoid leakage on this pin, as it may adversely affect operation.

## OPERATION

### Dual Input Overvoltage Protection

It is possible to protect both  $V_{BUS}$  and WALL from overvoltage damage with several additional components, as shown in Figure 5. Schottky diodes D1 and D2 pass the larger of V1 and V2 to R1 and OVSENS. If either V1 or V2 exceeds 6V plus  $V_{F(SCHOTTKY)}$ , OVGATE will be pulled to GND and both the WALL and USB inputs will be protected. Each input is protected up to the drain-source breakdown, BVDSS, of MN1 and MN2. R1 must also be rated for the power dissipated during maximum overvoltage. See the Overvoltage Protection section for an explanation of this calculation. Table 2 shows some N-channel MOSFETs that maybe suitable for overvoltage protection.

Table 2. Recommended Overvoltage FETs

N-CHANNEL MOSFET	BVDSS	$R_{ON}$	PACKAGE
Si1472DH	30V	82m $\Omega$	SC70-6
Si2302ADS	20V	60m $\Omega$	SOT-23
Si2306BDS	30V	65m $\Omega$	SOT-23
Si2316BDS	30V	80m $\Omega$	SOT-23
IRLML2502	20V	35m $\Omega$	SOT-23

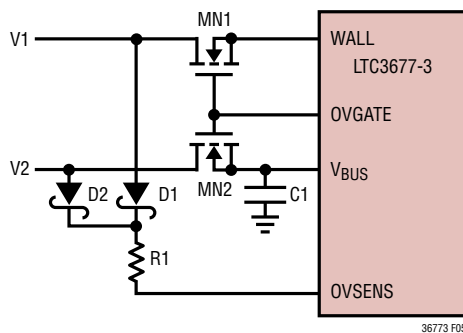

Figure 5. Dual Input Overvoltage Protection

### Reverse Input Voltage Protection

The LTC3677-3 can also be easily protected against the application of reverse voltage as shown in Figure 6. D1 and R1 are necessary to limit the maximum VGS seen by MP1 during positive overvoltage events. D1's breakdown voltage must be safely below MP1's BVGS. The circuit shown in Figure 6 offers forward voltage protection up to MN1's BVDSS and reverse voltage protection up to MP1's BVDSS.

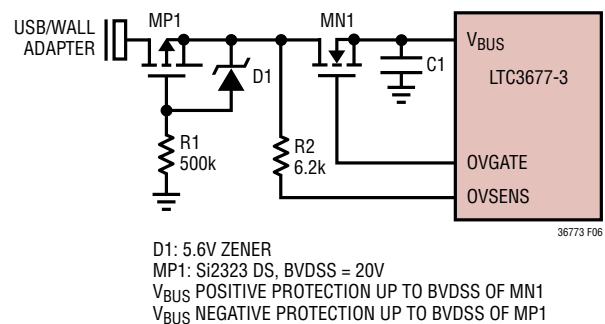

Figure 6. Dual Polarity Voltage Protection

## LOW DROPOUT LINEAR REGULATOR OPERATION

### LDO Operation and Voltage Programming

The LTC3677-3 contains two 150mA adjustable output LDO regulators. The first LDO (LDO1) is always on and will be enabled whenever  $V_{OUT}$  is greater than  $V_{OUT}$  UVLO. The second LDO (LDO2) is controlled by the pushbutton and is the first supply to sequence up in response to pushbutton application. Both LDOs are disabled when  $V_{OUT}$  is less than  $V_{OUT}$  UVLO and LDO2 is further disabled when the pushbutton circuitry is in the power down or power off states. Both LDOs contain a soft-start function to limit inrush current when enabled. The soft-start function works by ramping up the LDO reference over a 200 $\mu$ s period (typical) when the LDO is enabled.

When disabled all LDO circuitry is powered off leaving only a few nanoamps of leakage current on the LDO supply. Both LDO outputs are individually pulled to ground through internal resistors when disabled.

## OPERATION

The power good status bits of LDO1 and LDO2 are available in I<sup>2</sup>C through the read-back registers PGLDO[1] and PGLDO[2] for LDO1 and LDO2 respectively. The power good comparators for both LDOs are sampled when the I<sup>2</sup>C port receives the correct I<sup>2</sup>C read address.

Figure 7 shows the LDO application circuit. The full-scale output voltage for each LDO is programmed using a resistor divider from the LDO output (LDO1 or LDO2) connected to the feedback pins (LDO1\_FB or LDO2\_FB) such that:

$$V_{LDOx} = 0.8V \cdot \left( \frac{R1}{R2} + 1 \right)$$

For stability, each LDO output must be bypassed to ground with a minimum 1μF ceramic capacitor (C<sub>OUT</sub>).

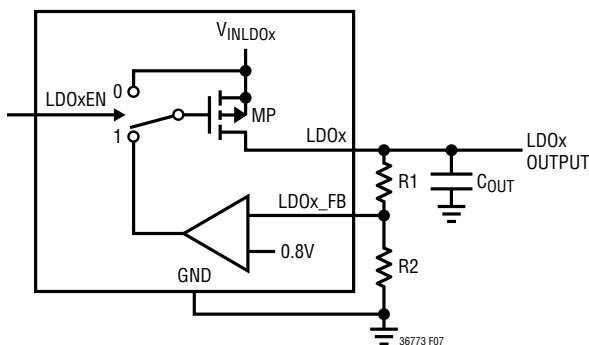

Figure 7. LDO Application Circuit

## STEP-DOWN SWITCHING REGULATOR OPERATION

### Introduction

The LTC3677-3 includes three 2.25MHz constant-frequency current mode step-down switching regulators providing 500mA, 500mA and 800mA each. All step-down switching regulators can be programmed for a minimum output voltage of 0.8V and can be used to power a microcontroller core, microcontroller I/O, memory or other logic circuitry. All step-down switching regulators support 100% duty cycle operation (low dropout mode) when the input voltage drops very close to the output voltage and are also capable of Burst Mode operation for highest efficiencies at light loads. Burst Mode operation is individually selectable for each step-down switching regulator through the I<sup>2</sup>C register bits BK1BRST, BK2BRST and BK3BRST. The

step-down switching regulators also include soft-start to limit inrush current when powering on, short-circuit current protection, and switch node slew limiting circuitry to reduce EMI radiation. No external compensation components are required for the switching regulators. Switching regulators 1 and 2 (Buck1 and Buck2) are sequenced up and down together through the pushbutton interface (see the Pushbutton Interface section for more information), while Buck3 has an individual enable pin (EN3) that is active when the pushbutton is in the power-up or power-on states. Buck3 is disabled in the power down and power off states. It is recommended that the step-down switching regulator input supplies (V<sub>IN12</sub> and V<sub>IN3</sub>) be connected to the system supply pin (V<sub>OUT</sub>). This is recommended because the undervoltage lockout circuit on the V<sub>OUT</sub> pin (V<sub>OUT</sub> UVLO) disables the step-down switching regulators when the V<sub>OUT</sub> voltage drops below the V<sub>OUT</sub> UVLO threshold. If driving the step-down switching regulator input supplies from a voltage other than V<sub>OUT</sub> the regulators should not be operated outside the specified operating range as operation is not guaranteed beyond this range.

### Output Voltage Programming

Figure 8 shows the step-down switching regulator application circuit. The full-scale output voltage for each step-down switching regulator is programmed using a resistor divider from the step-down switching regulator output connected to the feedback pins (FB1, FB2 and FB3) such that:

$$V_{OUTx} = 0.8V \cdot \left( \frac{R1}{R2} + 1 \right)$$

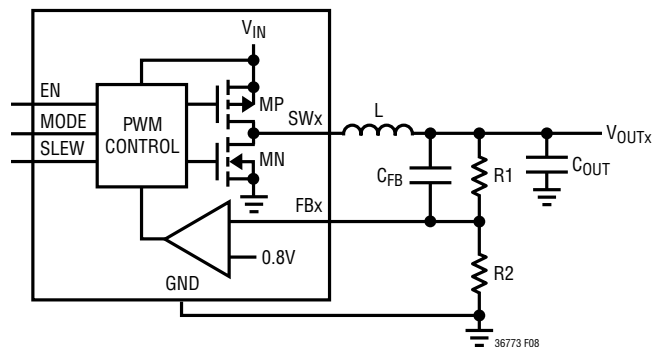

Figure 8. Step-Down Switching Regulator Application Circuit

## OPERATION

Typical values for R1 are in the range of 40k to 1M. The capacitor  $C_{FB}$  cancels the pole created by feedback resistors and the input capacitance of the FB pin and also helps to improve transient response for output voltages much greater than 0.8V. A variety of capacitor sizes can be used for  $C_{FB}$  but a value of 10pF is recommended for most applications. Experimentation with capacitor sizes between 2pF and 22pF may yield improved transient response.

### Operating Modes

The step-down switching regulators include two possible operating modes to meet the noise/power needs of a variety of applications. In pulse-skipping mode, an internal latch is set at the start of every cycle, which turns on the main P-channel MOSFET switch. During each cycle, a current comparator compares the peak inductor current to the output of an error amplifier. The output of the current comparator resets the internal latch, which causes the main P-channel MOSFET switch to turn off and the N-channel MOSFET synchronous rectifier to turn on. The N-channel MOSFET synchronous rectifier turns off at the end of the 2.25MHz cycle or if the current through the N-channel MOSFET synchronous rectifier drops to zero. Using this method of operation, the error amplifier adjusts the peak inductor current to deliver the required output power. All necessary compensation is internal to the step-down switching regulator requiring only a single ceramic output capacitor for stability. At light loads in pulse-skipping mode, the inductor current may reach zero on each pulse which will turn off the N-channel MOSFET synchronous rectifier. In this case, the switch node (SW1, SW2 or SW3) goes high impedance and the switch node voltage will ring. This is discontinuous operation, and is normal behavior for a switching regulator. At very light loads in pulse-skipping mode, the step-down switching regulators will automatically skip pulses as needed to maintain output regulation. At high duty cycle ( $V_{OUTX}$  approaching  $V_{INX}$ ) it is possible for the inductor current to reverse at light loads causing the stepped down switching regulator to operate continuously. When operating continuously, regulation and low noise output voltage are maintained, but input operating current will increase to a few milliamps.

In Burst Mode operation, the step-down switching regulators automatically switch between fixed frequency

PWM operation and hysteretic control as a function of the load current. At light loads the step-down switching regulators control the inductor current directly and use a hysteretic control loop to minimize both noise and switching losses. While operating in Burst Mode operation, the output capacitor is charged to a voltage slightly higher than the regulation point. The step-down switching regulator then goes into sleep mode, during which the output capacitor provides the load current. In sleep mode, most of the switching regulator's circuitry is powered down, helping conserve battery power. When the output voltage drops below a pre-determined value, the step-down switching regulator circuitry is powered on and another burst cycle begins. The sleep time decreases as the load current increases. Beyond a certain load current point (about 1/4 rated output load current) the step-down switching regulators will switch to a low noise constant-frequency PWM mode of operation, much the same as pulse-skipping operation at high loads.

For applications that can tolerate some output ripple at low output currents, Burst Mode operation provides better efficiency than pulse-skipping at light loads. The step-down switching regulators allow mode transition on-the-fly, providing seamless transition between modes even under load. This allows the user to switch back and forth between modes to reduce output ripple or increase low current efficiency as needed. Burst Mode operation is individually selectable for each step-down switching regulator through the I<sup>2</sup>C register bits BK1BRST, BK2BRST and BK3BRST.

### Shutdown

The step-down switching regulators (Buck1, Buck2 and Buck3) are shut down when the pushbutton circuitry is in the power-down or power-off state. Step-down switching regulator 3 (Buck3) can also be shut down by bringing the EN3 input low. In shutdown all circuitry in the step-down switching regulator is disconnected from the switching regulator input supply leaving only a few nanoamps of leakage current. The step-down switching regulator outputs are individually pulled to ground through internal 10k resistors on the switch pin (SW1, SW2 or SW3) when in shutdown.



## OPERATION

### Dropout Operation

It is possible for a step-down switching regulator's input voltage to approach its programmed output voltage (e.g., a battery voltage of 3.4V with a programmed output voltage of 3.3V). When this happens, the P-Channel MOSFET switch duty cycle increases until it is turned on continuously at 100%. In this dropout condition, the respective output voltage equals the regulator's input voltage minus the voltage drops across the internal P-channel MOSFET and the inductor.

### Soft-Start Operation

Soft-start is accomplished by gradually increasing the peak inductor current for each step-down switching regulator over a 500µs period. This allows each output to rise slowly, helping minimize inrush current required to charge up the switching regulator output capacitor. A soft-start cycle occurs whenever a given switching regulator is enabled. A soft-start cycle is not triggered by changing operating modes. This allows seamless output transition when actively changing between operating modes.

### Slew Rate Control

The step-down switching regulators contain patented circuitry to limit the slew rate of the switch node (SW1, SW2 and SW3). This new circuitry is designed to transition the switch node over a period of a few nanoseconds, significantly reducing radiated EMI and conducted supply noise while maintaining high efficiency. Since slowing the slew rate of the switch nodes causes efficiency loss, the slew rate of the step-down switching regulators is adjustable via the I<sup>2</sup>C registers SLEWCTL1 and SLEWCTL2. This allows the user to optimize efficiency or EMI as necessary with four different slew rate settings. The power up default is the fastest slew rate (highest efficiency) setting. Figures 9 and 10 show the efficiency and power loss graph for Buck3 programmed for 1.2V and 2.5V outputs. Note that the power loss curves remain fairly constant for both graphs yet changing the slew rate has a larger effect on the 1.2V output efficiency. This is mainly because for a given output current the 2.5V output is delivering more than 2x the power than the 1.2V output. Efficiency will always decrease and show more variation to slew rate as the programmed output voltage is decreased.

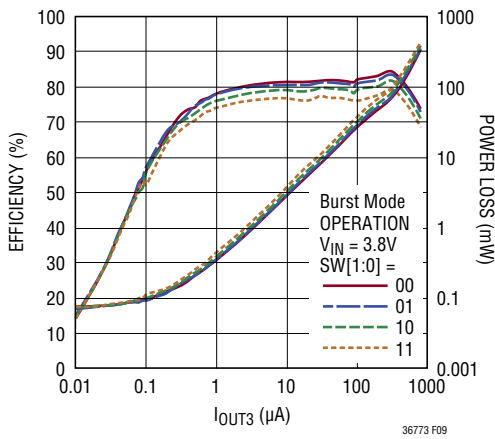

Figure 9. V<sub>OUT3</sub> (1.2V) Efficiency and Power Loss vs I<sub>OUT3</sub>

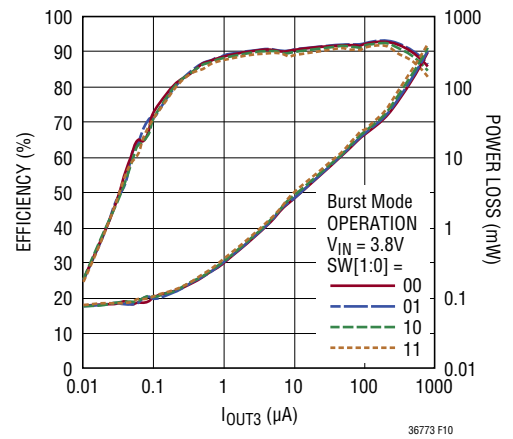

Figure 10. V<sub>OUT3</sub> (2.5V) Efficiency and Power Loss vs I<sub>OUT3</sub>

## OPERATION

### Low Supply Operation

An undervoltage lockout circuit on  $V_{OUT}$  ( $V_{OUT}$  UVLO) shuts down the step-down switching regulators when  $V_{OUT}$  drops below about 2.7V. It is recommended that the step-down switching regulator input supplies ( $V_{IN12}$ ,  $V_{IN3}$ ) be connected to the power path output ( $V_{OUT}$ ) directly. This UVLO prevents the step-down switching regulators from operating at low supply voltages where loss of regulation or other undesirable operation may occur. If driving the step-down switching regulator input supplies from a voltage other than the  $V_{OUT}$  pin, the regulators should not be operated outside the specified operating range as operation is not guaranteed beyond this range.

### Inductor Selection

Many different sizes and shapes of inductors are available from numerous manufacturers. Choosing the right inductor from such a large selection of devices can be overwhelming, but following a few basic guidelines will make the selection process much simpler. The step-down switching regulators are designed to work with inductors in the range of 2.2 $\mu$ H to 10 $\mu$ H. For most applications a 4.7 $\mu$ H inductor is suggested for step-down switching regulators providing

up to 500mA of output current while a 3.3 $\mu$ H inductor is suggested for step-down switching regulators providing up to 800mA. Larger value inductors reduce ripple current, which improves output ripple voltage. Lower value inductors result in higher ripple current and improved transient response time, but will reduce the available output current. To maximize efficiency, choose an inductor with a low DC resistance. For a 1.2V output, efficiency is reduced about 2% for 100m $\Omega$  series resistance at 400mA load current, and about 2% for 300m $\Omega$  series resistance at 100mA load current. Choose an inductor with a DC current rating at least 1.5 times larger than the maximum load current to ensure that the inductor does not saturate during normal operation. If output short circuit is a possible condition, the inductor should be rated to handle the maximum peak current specified for the step-down converters. Different core materials and shapes will change the size/current and price/current relationship of an inductor. Toroid or shielded pot cores in ferrite or Permalloy materials are small and do not radiate much energy, but generally cost more than powdered iron core inductors with similar electrical characteristics. Inductors that are very thin or have a very small volume typically have much higher core and DCR losses, and will not give the best efficiency. The

**Table 3. Recommended Inductors for Step-Down Switching Regulators**

INDUCTOR TYPE	L ( $\mu$ H)	MAX $I_{DC}$ (A)	MAX DCR ( $\Omega$ )	SIZE in mm (L $\times$ W $\times$ H)	MANUFACTURER
DB318C	4.7	1.07	0.1	3.8 $\times$ 3.8 $\times$ 1.8	Toko www.toko.com
	3.3	1.20	0.07	3.8 $\times$ 3.8 $\times$ 1.8	
D312C	4.7	0.79	0.24	3.6 $\times$ 3.6 $\times$ 1.2	
	3.3	0.90	0.20	3.6 $\times$ 3.6 $\times$ 1.2	
DE2812C	4.7	1.15	0.13*	3.0 $\times$ 2.8 $\times$ 1.2	
	3.3	1.37	0.105*	3.0 $\times$ 2.8 $\times$ 1.2	
CDRH3D16	4.7	0.9	0.11	4 $\times$ 4 $\times$ 1.8	Sumida www.sumida.com
	3.3	1.1	0.085	4 $\times$ 4 $\times$ 1.8	
CDRH2D11	4.7	0.5	0.17	3.2 $\times$ 3.2 $\times$ 1.2	
	3.3	0.6	0.123	3.2 $\times$ 3.2 $\times$ 1.2	
CLS4D09	4.7	0.75	0.19	4.9 $\times$ 4.9 $\times$ 1	
SD3118	4.7	1.3	0.162	3.1 $\times$ 3.1 $\times$ 1.8	Cooper www.cooperet.com
	3.3	1.59	0.113	3.1 $\times$ 3.1 $\times$ 1.8	
SD3112	4.7	0.8	0.246	3.1 $\times$ 3.1 $\times$ 1.2	
	3.3	0.97	0.165	3.1 $\times$ 3.1 $\times$ 1.2	
SD12	4.7	1.29	0.117*	5.2 $\times$ 5.2 $\times$ 1.2	
	3.3	1.42	0.104*	5.2 $\times$ 5.2 $\times$ 1.2	
SD10	4.7	1.08	0.153*	5.2 $\times$ 5.2 $\times$ 1.0	
	3.3	1.31	0.108*	5.2 $\times$ 5.2 $\times$ 1.0	
LPS3015	4.7	1.1	0.2	3.0 $\times$ 3.0 $\times$ 1.5	Coil Craft www.coilcraft.com
	3.3	1.3	0.13	3.0 $\times$ 3.0 $\times$ 1.5	

\*Typical DCR

36773f

## OPERATION

choice of which style inductor to use often depends more on the price versus size, performance, and any radiated EMI requirements than on what the step-down switching regulators requires to operate. The inductor value also has an effect on Burst Mode operation. Lower inductor values will cause Burst Mode switching frequency to increase. Table 3 shows several inductors that work well with the step-down switching regulators. These inductors offer a good compromise in current rating, DCR and physical size. Consult each manufacturer for detailed information on their entire selection of inductors.

### Input/Output Capacitor Selection

Low ESR (equivalent series resistance) ceramic capacitors should be used at both step-down switching regulator outputs as well as at each step-down switching regulator input supply. Only X5R or X7R ceramic capacitors should be used because they retain their capacitance over wider voltage and temperature ranges than other ceramic types. A 10 $\mu$ F output capacitor is sufficient for the step-down switching regulator outputs. For good transient response and stability the output capacitor for step-down switching regulators should retain at least 4 $\mu$ F of capacitance over operating temperature and bias voltage. Each switching regulator input supply should be bypassed with a 2.2 $\mu$ F capacitor. Consult with capacitor manufacturers for detailed information on their selection and specifications of ceramic capacitors. Many manufacturers now offer very thin (<1mm tall) ceramic capacitors ideal for use in height-restricted designs. Table 4 shows a list of several ceramic capacitor manufacturers.

**Table 4. Ceramic Capacitor Manufacturers**

AVX	<a href="http://www.avxcorp.com">www.avxcorp.com</a>
Murata	<a href="http://www.murata.com">www.murata.com</a>
Taiyo Yuden	<a href="http://www.t-yuden.com">www.t-yuden.com</a>
Vishay Siliconix	<a href="http://www.vishay.com">www.vishay.com</a>
TDK	<a href="http://www.tdk.com">www.tdk.com</a>

## I<sup>2</sup>C OPERATION

### I<sup>2</sup>C Interface

The LTC3677-3 may communicate with a bus master using the standard I<sup>2</sup>C 2-wire interface. The timing diagram in Figure 11 shows the relationship of the signals on the bus. The two bus lines, SDA and SCL, must be HIGH when the bus is not in use. External pull-up resistors or current sources, such as the LTC1694 SMBus accelerator, are required on these lines. The LTC3677-3 is both a slave receiver and slave transmitter. The I<sup>2</sup>C control signals, SDA and SCL are scaled internally to the DV<sub>CC</sub> supply. DV<sub>CC</sub> should be connected to the same power supply as the bus pull-up resistors.

The I<sup>2</sup>C port has an undervoltage lockout on the DV<sub>CC</sub> pin. When DV<sub>CC</sub> is below approximately 1V, the I<sup>2</sup>C serial port is cleared and registers are set to the default configuration of all zeros.

### I<sup>2</sup>C Bus Speed

The I<sup>2</sup>C port is designed to be operated at speeds of up to 400kHz. It has built-in timing delays to ensure correct operation when addressed from an I<sup>2</sup>C compliant master device. It also contains input filters designed to suppress glitches should the bus become corrupted.

### I<sup>2</sup>C START and STOP Conditions

A bus master signals the beginning of communications by transmitting a START condition. A START condition is generated by transitioning SDA from HIGH to LOW while SCL is HIGH. The master may transmit either the slave write or the slave read address. Once data is written to the LTC3677-3, the master may transmit a STOP condition which commands the LTC3677-3 to act upon its new command set. A STOP condition is sent by the master by transitioning SDA from LOW to HIGH while SCL is HIGH. The bus is then free for communication with another I<sup>2</sup>C device.

### I<sup>2</sup>C Byte Format

Each byte sent to or received from the LTC3677-3 must be 8 bits long followed by an extra clock cycle for the acknowledge bit. The data should be sent to the LTC3677-3 most significant bit (MSB) first.



## OPERATION

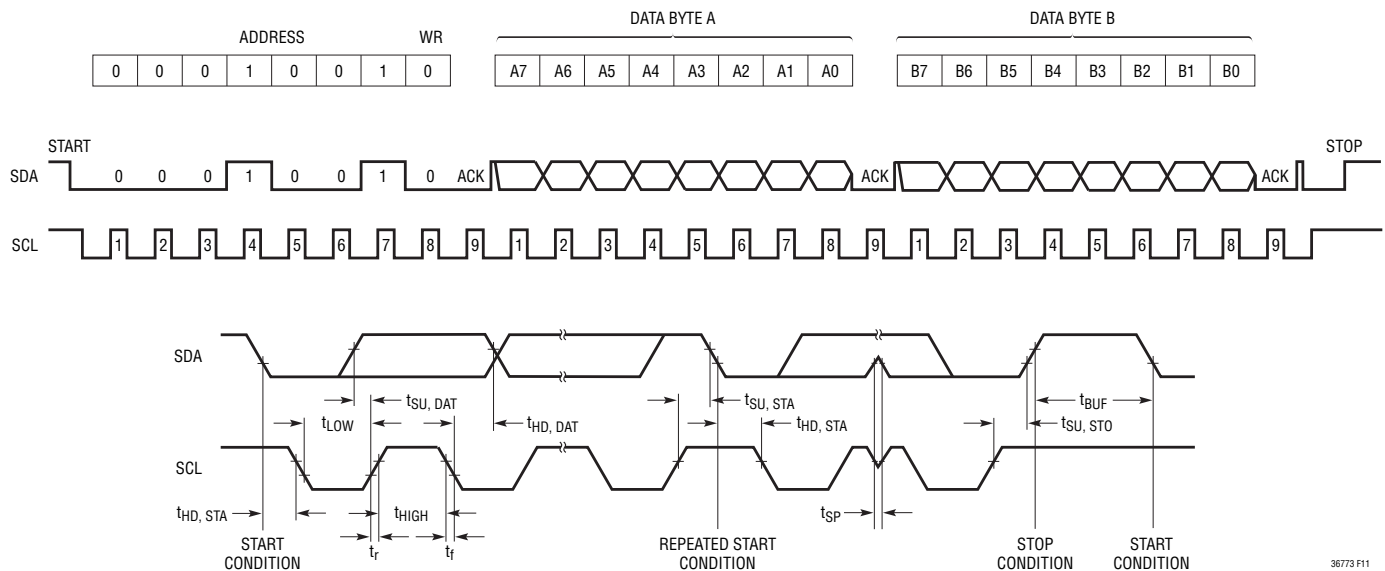

Figure 11. I<sup>2</sup>C Timing Diagram

### I<sup>2</sup>C Acknowledge

The acknowledge signal is used for handshaking between the master and the slave. When the LTC3677-3 is written to (write address), it acknowledges its write address as well as the subsequent two data bytes. When read from (read address), the LTC3677-3 acknowledges its read address only. The bus master should acknowledge receipt of information from the LTC3677-3.

An acknowledge (active LOW) generated by the LTC3677-3 lets the master know that the latest byte of information was received. The acknowledge related clock pulse is generated by the master. The master releases the SDA line (HIGH) during the acknowledge clock cycle. The LTC3677-3 pulls down the SDA line during the write acknowledge clock pulse so that it is a stable LOW during the HIGH period of this clock pulse.

When the LTC3677-3 is read from, it releases the SDA line so that the master may acknowledge receipt of the data. Since the LTC3677-3 only transmits one byte of data, a master not acknowledging the data sent by the LTC3677-3 has no I<sup>2</sup>C specific consequence on the operation of the I<sup>2</sup>C port.

### I<sup>2</sup>C Slave Address

The LTC3677-3 responds to a 7-bit address which has been factory programmed to b'0001001[R/W]'. The LSB of the address byte, known as the read/write bit, should be 0 when writing data to the LTC3677-3 and 1 when reading data from it. Considering the address an 8-bit word, then the write address is 0x12 and the read address is 0x13. The LTC3677-3 will acknowledge both its read and write address.

### I<sup>2</sup>C Sub-Addressed Writing

The LTC3677-3 has one command register for control input. It is accessed by the I<sup>2</sup>C port via a sub-addressed writing system.

Each write cycle of the LTC3677-3 consists of exactly three bytes. The first byte is always the LTC3677-3's write address. The second byte represents the LTC3677-3's sub-address. The sub-address is a pointer which directs the subsequent data byte within the LTC3677-3. The third byte consists of the data to be written to the location pointed to by the sub-address. The LTC3677-3 contains control registers at only sub-address location 0x00. Sub-addresses outside 0x00 should not be written to as they access functionality not available in the LTC3677-3.

36773 F11

## OPERATION

### I<sup>2</sup>C Bus Write Operation

The master initiates communication with the LTC3677-3 with a START condition and the LTC3677-3's write address. If the address matches that of the LTC3677-3, the LTC3677-3 returns an acknowledge. The master should then deliver the sub-address. Again the LTC3677-3 acknowledges and the cycle is repeated for the data byte. The data byte is transferred to an internal holding latch upon the return of its acknowledge by the LTC3677-3. This procedure must be repeated for each sub-address that requires new data. After one or more cycles of [ADDRESS][SUB-ADDRESS][DATA], the master may terminate the communication with a STOP condition. Alternatively, a REPEAT-START condition can be initiated by the master and another chip on the I<sup>2</sup>C bus can be addressed. This cycle can continue indefinitely and the LTC3677-3 will remember the last input of valid data that it received. Once all chips on the bus have been addressed and sent valid data, a global STOP can be sent and the LTC3677-3 will update its command latches with the data that it received.

### I<sup>2</sup>C Bus Read Operation

The bus master reads the status of the LTC3677-3 with a START condition followed by the LTC3677-3 read address. If the read address matches that of the LTC3677-3, the LTC3677-3 returns an acknowledge. Following the acknowledgement of their read address, the LTC3677-3 returns one bit of status information for each of the next 8 clock cycles. A STOP command is not required for the bus read operation.

### I<sup>2</sup>C Input Data

There is one byte of data that can be written to on the LTC3677-3. The byte is accessed through the sub-address 0x00. At first power application ( $V_{BUS}$ , WALL or BAT)

all bits default to 0. Additionally, all bits are cleared to 0 when  $DV_{CC}$  drops below its undervoltage lock out or if the pushbutton enters the power down (PDN) state.

Table 5 shows the byte of data that can be written to at sub-address 0x00. This byte of data is referred to as the buck control register.

**Table 5. Buck Control Register**

BUCK CONTROL REGISTER		ADDRESS: 00010010 SUB-ADDRESS: 00000000
BIT	NAME	FUNCTION
B0	N/A	Not Used—No Effect On Operation
B1	N/A	Not Used—No Effect On Operation
B2	BK1BRST	Buck1 Burst Mode Enable
B3	BK2BRST	Buck2 Burst Mode Enable
B4	BK3BRST	Buck2 Burst Mode Enable
B5	SLEWCTL1	Buck SW Slew Rate: 00 = 1ns, 01 = 2ns, 10 = 4ns, 11 = 8ns
B6	SLEWCTL2	
B7	N/A	Not Used—No Effect On Operation

Bits B2, B3, and B4 set the operating modes of the step-down switching regulators (bucks). Writing a 1 to any of these three registers will put that respective buck converter in the high efficiency Burst Mode operation, while a 0 will enable the low noise pulse-skipping mode of operation.

The B5 and B6 bits adjust the slew rate of all SW pins together so they all slew at the same rate. It is recommended that the fastest slew rate (B6:B5 = 00) be used unless EMI is an issue in the application as slower slew rates cause reduced efficiency.

### I<sup>2</sup>C Output Data

One status byte may be read from the LTC3677-3, as shown in Table 6. A 1 read back in the any of the bit posi-

## OPERATION

tions indicates that the condition is true. For example, 1 read back from bit A3 indicate that LDO1 is enabled and regulating correctly. A status read from the LTC3677-3 captures the status information when the LTC3677-3 acknowledge its read address.

**Table 6. I<sup>2</sup>C READ Register**

STATUS REGISTER		ADDRESS: 00010011 SUB-ADDRESS: None
BIT	NAME	FUNCTION
A0	CHARGE	Charge Status (1 = Charging)
A1	STAT[0]	STAT[1:0]; 00 = No Fault 01 = TOO COLD/HOT 10 = BATTERY OVERTEMP 11 = BATTERY FAULT
A2	STAT[1]	
A3	PGLDO[1]	LDO1 Power Good
A4	PGLDO[2]	LDO2 Power Good
A5	PGBCK[1]	Buck1 Power Good
A6	PGBCK[2]	Buck2 Power Good
A7	PGBCK[3]	Buck3 Power Good

Bit A7 shows the power good status of Buck3. A 1 indicates that Buck3 is enabled and is regulating correctly. A 0 indicates that either Buck3 is not enabled, or that the Buck3 is enabled, but is out of regulation by more than 8%.

Bit A6 shows the power good status of Buck2. A 1 indicates that Buck2 is enabled and is regulating correctly. A 0 indicates that either Buck2 is not enabled, or that the Buck2 is enabled, but is out of regulation by more than 8%.

Bit A5 shows the power good status of Buck1. A 1 indicates that Buck1 is enabled and is regulating correctly. A 0 indicates that either Buck1 is not enabled, or that the Buck1 is enabled, but is out of regulation by more than 8%.

Bit A4 shows the power good status of LDO2. A 1 indicates that LDO2 is enabled and is regulating correctly. A 0 indi-

cates that either LDO2 is not enabled, or that the LDO2 is enabled, but is out of regulation by more than 8%.

Bit A3 shows the power good status of LDO1. A 1 indicates that LDO1 is enabled and is regulating correctly. A 0 indicates that either LDO1 is not enabled, or that the LDO1 is enabled, but is out of regulation by more than 8%.

Bits A2 and A1 indicate the fault status of the charger measurement circuit and are decoded in Table 6. The too cold/hot state indicates that the thermistor temperature is out of the valid charging range (either below 0°C or above 40°C for a curve 1 thermistor) and that charging has paused until the battery returns to valid charging temperature. The battery overtemperature state indicates that the battery's thermistor has reached a critical temperature (about 50°C for a curve 1 thermistor) and that long-term battery capacity may be seriously compromised if the condition persists. The battery fault state indicates that an attempt was made to charge a low battery (typically < 2.85V) but that the low voltage condition persisted for more than 1/2 hour. In this case charging has terminated.

Bit A0 indicates the status of the battery charger. A 1 indicates that the charger is enabled and is in the constant-current charge state. In this case the battery is being charged unless the NTC thermistor is outside its valid charge range in which case charging is temporarily suspended but not complete. Charging will continue once the battery has returned to a valid charging temperature. A 0 in bit A0 indicates that charger has reached end-of-charge ( $h_{C/10}$ ) and is near  $V_{FLOAT}$  or that charging has been terminated. Charging can be terminated by reaching the end of the charge timer or by a battery fault as described previously.

## OPERATION

### PUSHBUTTON INTERFACE OPERATION

#### State Diagram/Operation

Figure 13 shows the LTC3677-3 pushbutton state diagram. Upon first application of power ( $V_{BUS}$ , WALL or BAT) an internal power-on reset (POR) signal places the pushbutton circuitry into the power-off (POFF) state. The following events cause the state machine to transition out of POFF into the power-up (PUP) state:

- 1)  $\overline{ON}$  input LOW for 50ms (PB50MS)
- 2) PWR\_ON input going HIGH (PWR\_ON)

Upon entering the PUP state, the pushbutton circuitry will sequence up LDO2, Buck1 and Buck2 in that order. One second after entering the PUP state, the pushbutton circuitry will transition into the power-on (PON) state. Note that the PWR\_ON input must be brought HIGH before entering the PON state if the part is to remain in the PON state. Buck3 can be enabled through the EN3 input once the pushbutton is in the PUP or PON states.

PWR\_ON going LOW, or  $V_{OUT}$  dropping to its undervoltage lockout ( $V_{OUT\ UVLO}$ ) threshold will cause the state machine to leave the PON state and enter the power-down (PDN) state. The PDN state resets the I<sup>2</sup>C registers as well as disables Buck1, Buck2 and LDO2 together. Buck3 is also disabled in the PDN and POFF states. The one second delay before leaving the power-down state allows the supplies to power down completely before they can be re-enabled.

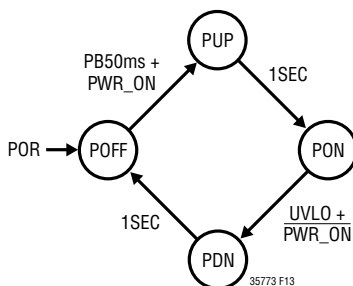

Figure 12. Pushbutton State Diagram

#### PBSTAT Operation

PBSTAT goes LOW 50ms after the initial pushbutton application ( $\overline{ON}$  LOW) and will stay low for 50ms minimum. PBSTAT will go HIGH coincident with  $\overline{ON}$  going HIGH unless  $\overline{ON}$  goes HIGH before the 50ms minimum LOW time.

#### Hard Reset and PGOOD Operation

The hard reset event is generated by pressing and holding the pushbutton ( $\overline{ON}$  input LOW) for 14 seconds. For a valid hard reset event to occur the initial pushbutton application must start in the PUP or PON state. This avoids causing a hard reset from occurring if the user hangs on the pushbutton during initial power-up. If a valid hard reset event is present then the PGOOD output will transition LOW for about 1.8ms to allow the microprocessor to reset. The hard reset event does not affect the operating state or regulator operation.

The PGOOD pin is an open-drain output used to indicate that Buck1, Buck2 and LDO1 are enabled and have reached their final regulation voltage. A 230ms delay is included from the time Buck1, Buck2 and LDO1 reach 92% of their regulation value to allow a system controller ample time to reset itself. PGOOD is an open-drain output and requires a pull-up resistor to an appropriate power source. Optimally the pull-up resistor is connected to the output of Buck1, Buck2 or LDO2 so that power is not dissipated while the regulators are disabled.

#### Pushbutton Operation and $V_{OUT\ UVLO}$

As stated earlier  $V_{OUT}$  dropping to its UVLO threshold will cause the pushbutton to leave the power-on state and enter the power-down state, thus powering down Buck1, Buck2, Buck3 and LDO2. Additionally, LDO1 is disabled when in UVLO. Thus, all LTC3677-3 supplies are disabled and remain disabled as long as the  $V_{OUT\ UVLO}$  condition exists. It is not possible to power up any of the LTC3677-3 generated supplies while  $V_{OUT}$  is below the  $V_{OUT\ UVLO}$  threshold.

## OPERATION

### Power-Up via Pushbutton Timing

The timing diagram, Figure 13, shows the LTC3677-3 powering up through application of the external pushbutton. For this example the pushbutton circuitry starts in the POFF state with  $V_{OUT}$  not in UVLO and Buck1, Buck2 and LDO2 disabled. Pushbutton application ( $\overline{ON}$  LOW) for 50ms transitions the pushbutton circuitry into the PUP state which sequences up LDO2, Buck1 and Buck2 in that order. PWR\_ON must be driven HIGH before the 1 second PUP period is over to keep supplies up. If PWR\_ON is LOW or goes LOW after the 1 second PUP period Buck1, Buck2, and LDO2 will be shut down together. PGOOD is asserted once Buck1, Buck2 and LDO1 are within 8% of their regulation voltage for 230ms.

Buck3 can be enabled and disabled at any time via EN3 once in the PUP or PON states. The PWR\_ON input can be driven via a  $\mu P/\mu C$  or by one of the sequenced outputs through a high impedance (100k $\Omega$  typ). PBSTAT goes LOW 50ms after the initial pushbutton application and will stay LOW for 50ms minimum. PBSTAT will go HIGH coincident with  $\overline{ON}$  going HIGH unless  $\overline{ON}$  goes HIGH before the 50ms minimum LOW time.

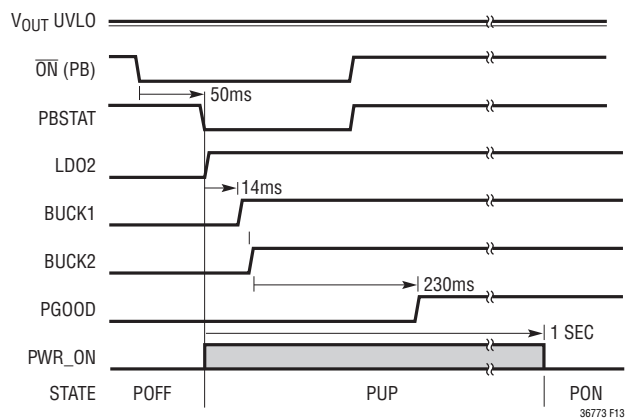

Figure 13. Power-Up via Pushbutton

### Power-Up via PWR\_ON Timing

The timing diagram, Figure 14, shows the LTC3677-3 powering up by driving PWR\_ON HIGH. For this example the pushbutton circuitry starts in the POFF state with  $V_{OUT}$  not in UVLO and Buck1, Buck2 and LDO2 disabled. 50ms after PWR\_ON goes HIGH the pushbutton circuitry transitions into the PUP state which sequences up LDO2, Buck1 and Buck2 in that order. PWR\_ON must be driven high before the 1 second PUP period is over to keep supplies up. If PWR\_ON is LOW or goes LOW after the 1 second PUP period Buck1, Buck2 and LDO2 will be shut down together. PGOOD is asserted once Buck1, Buck2 and LDO1 are within 8% of their regulation voltage for 230ms.

Buck3 can be enabled and disabled at any time via EN3 once in the PUP or PON states.

Powering up via PWR\_ON is useful for applications containing an always on microcontroller. This allows the microcontroller to power the application up and down for house keeping and other activities outside the user's control.

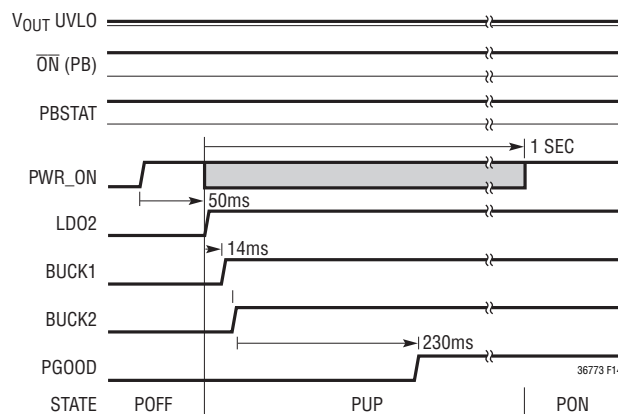

Figure 14. Power-Up via PWR\_ON

## OPERATION

### Power Down via Pushbutton Timing

The timing diagram, Figure 15, shows the LTC3677-3 powering down by  $\mu\text{C}/\mu\text{P}$  control. For this example the pushbutton circuitry starts in the PON state with  $V_{\text{OUT}}$  not in UVLO and Buck1, Buck2 and LDO2 enabled. In this case the pushbutton is applied ( $\overline{\text{ON}}$  LOW) for at least 50ms, which generates a low impedance on the PBSTAT output. After receiving the PBSTAT the  $\mu\text{C}/\mu\text{P}$  will drive the PWR\_ON input LOW. 50ms after PWR\_ON goes LOW the pushbutton circuitry will enter the PDN state. Buck1, Buck2 and LDO2 are disabled together upon entering the PDN state. After entering the PDN state, a 1 second wait time is initiated before entering the POFF state. During this 1 second time  $\overline{\text{ON}}$  and PWR\_ON inputs are ignored to allow all LTC3677-3 generated supplies to go LOW.

Upon entering the PDN state Buck3 is disabled and the I<sup>2</sup>C registers are cleared. Holding  $\overline{\text{ON}}$  LOW through the 1 second power-down period will not cause a power-up event at end of the 1 second period. The  $\overline{\text{ON}}$  input must be brought HIGH following the power-down event and then go LOW again to establish a valid power-up event.

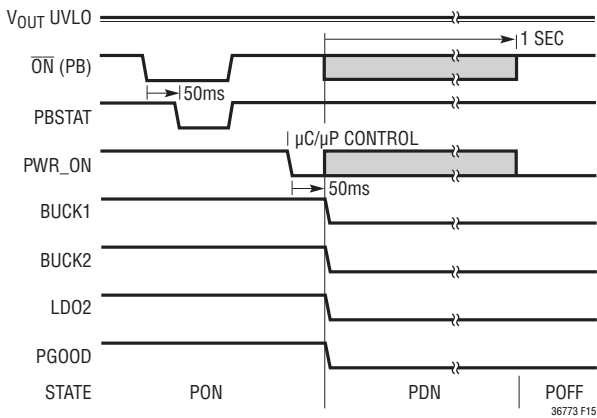

Figure 15. Power-Down via Pushbutton

### $V_{\text{OUT}}$ UVLO Power-Down Timing

If  $V_{\text{OUT}}$  drops below the  $V_{\text{OUT}}$  UVLO threshold, the pushbutton circuitry will transition from the PON state to the PDN state. Buck1, Buck2 and LDO2 are disabled together upon entering the PDN state. After entering the PDN state, a 1 second wait time is initiated before entering the POFF state. During this 1 second time  $\overline{\text{ON}}$  and PWR\_ON inputs are ignored to allow all LTC3677-3 generated supplies to go LOW.

Upon entering the PDN state the Buck3 is disabled and the I<sup>2</sup>C registers are cleared. LDO1 is also disabled by the  $V_{\text{OUT}}$  UVLO and stays disabled as long as the  $V_{\text{OUT}}$  UVLO condition remains. Note that it is not possible to sequence any of the supplies up while the  $V_{\text{OUT}}$  UVLO condition exists. LDO1 will be re-enabled when the  $V_{\text{OUT}}$  UVLO condition is removed. The other supplies will remain disabled until a valid power-up pushbutton event takes place.

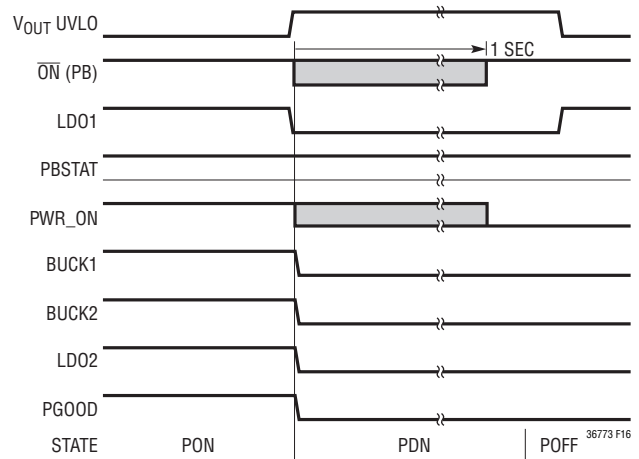

Figure 16.  $V_{\text{OUT}}$  UVLO Power-Down



## OPERATION

### Hard Reset Timing

Hard reset provides a way to reset the  $\mu\text{C}/\mu\text{P}$  in case of a software lockup. To initiate a hard reset, the pushbutton is pressed ( $\overline{\text{ON}}$  LOW) and held for greater than 14 seconds. Once the hard reset time is exceeded the PGOOD input will go LOW for 1.8ms which resets the  $\mu\text{C}/\mu\text{P}$ . Operation of the enabled supplies is not effected by the hard reset event. All enabled supplies should remain in regulation and operating correctly assuming specified operating conditions are met (i.e., no shorted supplies, etc).

There are only two methods to power down the LTC3677-3 supplies: 1) PWR\_ON goes LOW; 2)  $V_{\text{OUT}}$  drops below the  $V_{\text{OUT}}$  UVLO threshold. If the  $\mu\text{C}/\mu\text{P}$  controls shutdown by bringing PWR\_ON LOW, it is possible that the application can hang with all supplies enabled if the  $\mu\text{C}/\mu\text{P}$  fails to reset correctly on hard reset. In this case the battery will continue to be drained until  $V_{\text{OUT}}$  drops below the  $V_{\text{OUT}}$  UVLO threshold, or the user intervenes to shut down the application manually. The application can be shut down manually by removing the battery and any external supplies, or by providing a suicide button that will bring PWR\_ON LOW when pressed.

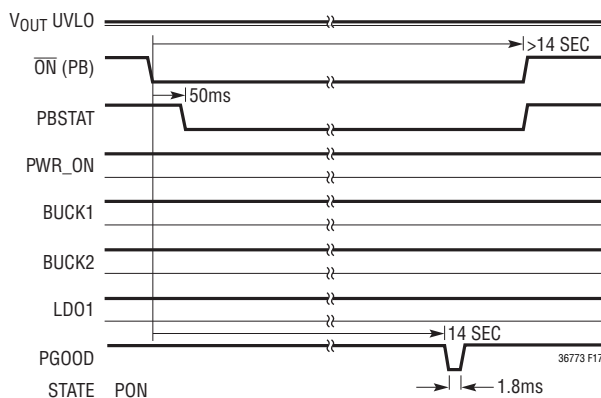

Figure 17. Hard Reset Timing

### Power-Up Sequencing

Figure 18 shows the actual power-up sequencing of the LTC3677-3. Buck1, Buck2 and LDO2 are all initially disabled (0V). Once the pushbutton has been applied ( $\overline{\text{ON}}$  LOW) for 50ms PBSTAT goes LOW and LDO2 is enabled. Once enabled, LDO2 slews up and enters regulation. The actual slew rate is controlled by the soft-start function of LDO2 which ramps the LDO reference up over a 200 $\mu\text{s}$  period typically. After a 14ms delay from LDO2 being enabled, Buck1 is enabled and slews up into regulation. When Buck1 is within about 8% of final regulation, Buck2 is enabled and slews up into regulation. The bucks also have a soft-start function to limit inrush current at start-up. 230ms after Buck2 is within 8% of final regulation, the PGOOD output will go high impedance (not shown in Figure 18). The regulators in Figure 18 are slewing up with nominal output capacitors and no load. Adding a load or increasing output capacitance on any of the outputs will reduce the slew rate and lengthen the time it takes the regulator to get into regulation.

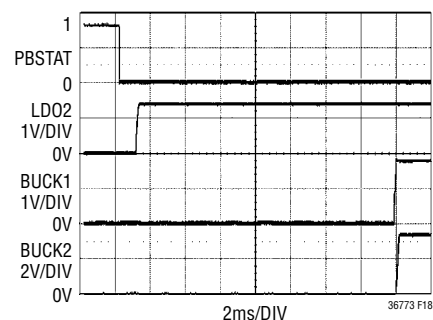

Figure 18. Power-Up Sequencing

## OPERATION

### LAYOUT AND THERMAL CONSIDERATIONS

#### Printed Circuit Board Power Dissipation

In order to be able to deliver maximum charge current under all conditions, it is critical that the exposed ground pad on the backside of the LTC3677-3 package be soldered to a ground plane on the board. Correctly soldered to 2500mm<sup>2</sup> ground plane on a double-sided 1oz copper board the LTC3677-3 has a thermal resistance ( $\theta_{JA}$ ) of approximately 45°C/W. Failure to make good thermal contact between the exposed pad on the backside of the package and an adequately sized ground plane will result in thermal resistances far greater than 45°C/W.

The conditions that cause the LTC3677-3 to reduce charge current due to the thermal protection feedback can be approximated by considering the power dissipated in the part. For high charge currents with a wall adapter applied to  $V_{OUT}$ , the LTC3677-3 power dissipation is approximately:

$$P_D = (V_{OUT} - BAT) \cdot I_{BAT} + P_{DREGS}$$

where  $P_D$  is the total power dissipated,  $V_{OUT}$  is the supply voltage,  $BAT$  is the battery voltage and  $I_{BAT}$  is the battery charge current.  $P_{DREGS}$  is the sum of power dissipated on-chip by the step-down switching, and LDO regulators.

The power dissipated by a step-down switching regulator can be estimated as follows:

$$P_{D(SW_x)} = (OUT_x \cdot I_{OUT_x}) \cdot \frac{100 - \text{Eff}}{100}$$

where  $OUT_x$  is the programmed output voltage,  $I_{OUT_x}$  is the load current and  $\text{Eff}$  is the % efficiency which can be measured or looked up on an efficiency table for the programmed output voltage.

The power dissipated on chip by a LDO regulator can be estimated as follows:

$$P_{DLDO_x} = (V_{INLDO_x} - LDO_x) \cdot I_{LDO_x}$$

where  $LDO_x$  is the programmed output voltage,  $V_{INLDO_x}$  is the LDO supply voltage and  $I_{LDO_x}$  is the LDO output load current. Note that if the LDO supply is connected to one of the buck output, then its supply current must be added to the buck regulator load current for calculating the buck power loss.

Thus the power dissipated by all regulators is:

$$P_{DREGS} = P_{DSW1} + P_{DSW2} + P_{DSW3} + P_{DLDO1} + P_{DLDO2}$$

It is not necessary to perform any worst-case power dissipation scenarios because the LTC3677-3 will automatically reduce the charge current to maintain the die temperature at approximately 110°C. However, the approximate ambient temperature at which the thermal feedback begins to protect the IC is:

$$T_A = 110^\circ\text{C} - P_D \cdot \theta_{JA}$$

Example: Consider the LTC3677-3 operating from a wall adapter with 5V ( $V_{OUT}$ ) providing 1A ( $I_{BAT}$ ) to charge a Li-Ion battery at 3.3V ( $BAT$ ). Also assume  $P_{DREGS} = 0.3W$ , so the total power dissipation is:

$$P_D = (5V - 3.3V) \cdot 1A + 0.3W = 2W$$

The ambient temperature above which the LTC3677-3 begins to reduce the 1A charge current, is approximately

$$T_A = 110^\circ\text{C} - 2W \cdot 45^\circ\text{C/W} = 20^\circ\text{C}$$

The LTC3677-3 can be used above 20°C, but the charge current will be reduced below 1A. The charge current at a given ambient temperature can be approximated by:

$$P_D = \frac{110^\circ\text{C} - T_A}{\theta_{JA}} = (V_{OUT} - BAT) \cdot I_{BAT} + P_{D(REGS)}$$

Thus:

$$I_{BAT} = \frac{(110^\circ\text{C} - T_A)}{\theta_{JA} - P_{D(REGS)}} \cdot \frac{1}{V_{OUT} - BAT}$$



## OPERATION

Consider the previous example with an ambient temperature of 55°C. The charge current will be reduced to approximately:

$$I_{\text{BAT}} = \frac{\frac{110^{\circ}\text{C} - 55^{\circ}\text{C}}{45^{\circ}\text{C}/\text{W}} - 0.3\text{W}}{5\text{V} - 3.3\text{V}}$$

$$I_{\text{BAT}} = \frac{1.22 - 0.3\text{W}}{1.7\text{V}} = 542\text{mA}$$

### Printed Circuit Board Layout

When laying out the printed circuit board, the following list should be followed to ensure proper operation of the LTC3677-3:

1. The exposed pad of the package (Pin 45) should connect directly to a large ground plane to minimize thermal and electrical impedance.
2. The step-down switching regulator input supply pins ( $V_{\text{IN}12}$  and  $V_{\text{IN}3}$ ) and their respective decoupling capacitors should be kept as short as possible. The GND side of these capacitors should connect directly to the ground plane of the part. These capacitors provide the AC current to the internal power MOSFETs and their drivers. It's important to minimizing inductance from these capacitors to the pins of the LTC3677-3.
3. The switching power traces connecting SW1, SW2, and SW3 to their respective inductors should be minimized to reduce radiated EMI and parasitic coupling. Due to the large voltage swing of the switching nodes, sensitive nodes such as the feedback nodes (FBx and LDOx\_FB) should be kept far away or shielded from the switching nodes or poor performance could result.
4. Connections between the step-down switching regulator inductors and their respective output capacitors should be kept as short as possible. The GND side of the output capacitors should connect directly to the thermal ground plane of the part.
5. Keep the buck feedback pin traces (FB1, FB2, and FB3) as short as possible. Minimize any parasitic capacitance between the feedback traces and any switching node (i.e., SW1, SW2, SW3, and logic signals). If necessary shield the feedback nodes with a GND trace.
6. Connections between the LTC3677-3 power path pins ( $V_{\text{BUS}}$  and  $V_{\text{OUT}}$ ) and their respective decoupling capacitors should be kept as short as possible. The GND side of these capacitors should connect directly to the ground plane of the part.

## TYPICAL APPLICATION

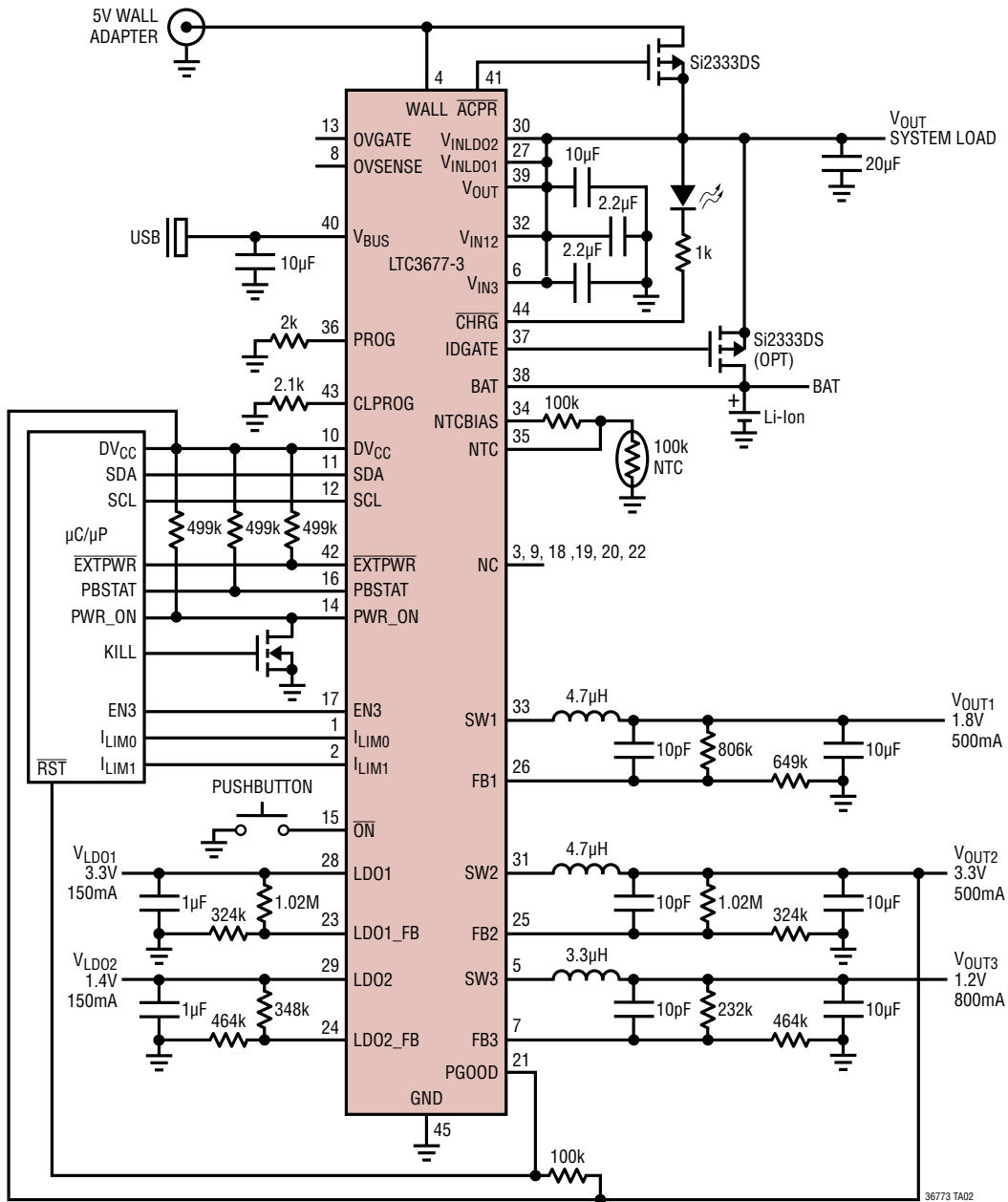

36773 TA02

# PACKAGE DESCRIPTION

**UFF Package**  
**Variation: UFFMA**  
**44-Lead Plastic QFN (4mm × 7mm)**  
 (Reference LTC DWG # 05-08-1762 Rev 0)

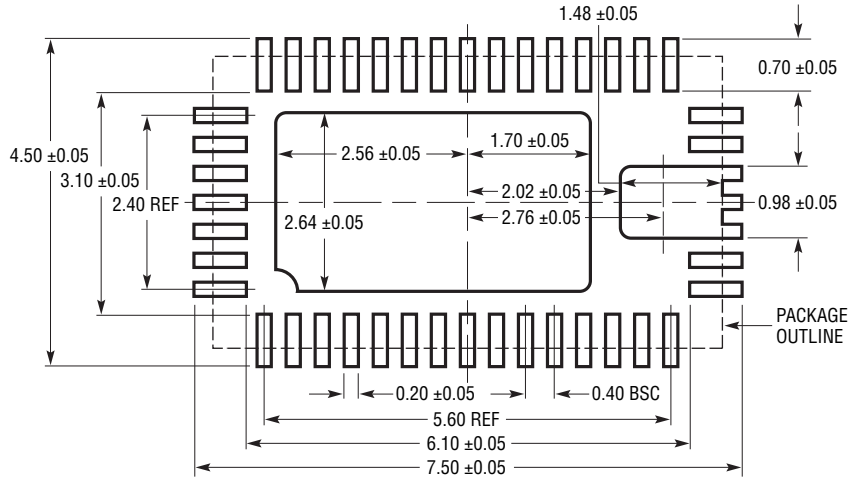

RECOMMENDED SOLDER PAD LAYOUT  
 APPLY SOLDER MASK TO AREAS THAT ARE NOT SOLDERED

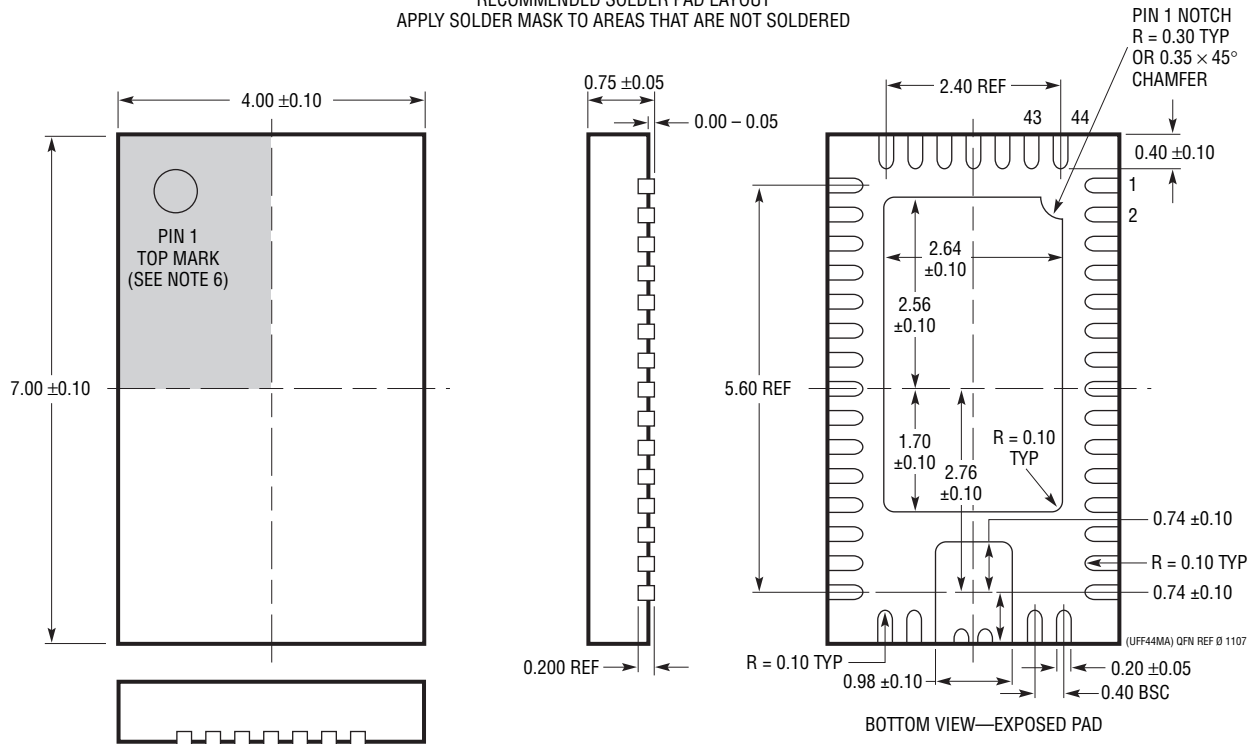

**NOTE:**

1. DRAWING IS NOT A JEDEC PACKAGE OUTLINE
2. DRAWING NOT TO SCALE
3. ALL DIMENSIONS ARE IN MILLIMETERS
4. DIMENSIONS OF EXPOSED PAD ON BOTTOM OF PACKAGE DO NOT INCLUDE MOLD FLASH. MOLD FLASH, IF PRESENT, SHALL NOT EXCEED 0.20mm ON ANY SIDE
5. EXPOSED PAD SHALL BE SOLDER PLATED
6. SHADED AREA IS ONLY A REFERENCE FOR PIN 1 LOCATION ON THE TOP AND BOTTOM OF PACKAGE

## TYPICAL APPLICATION

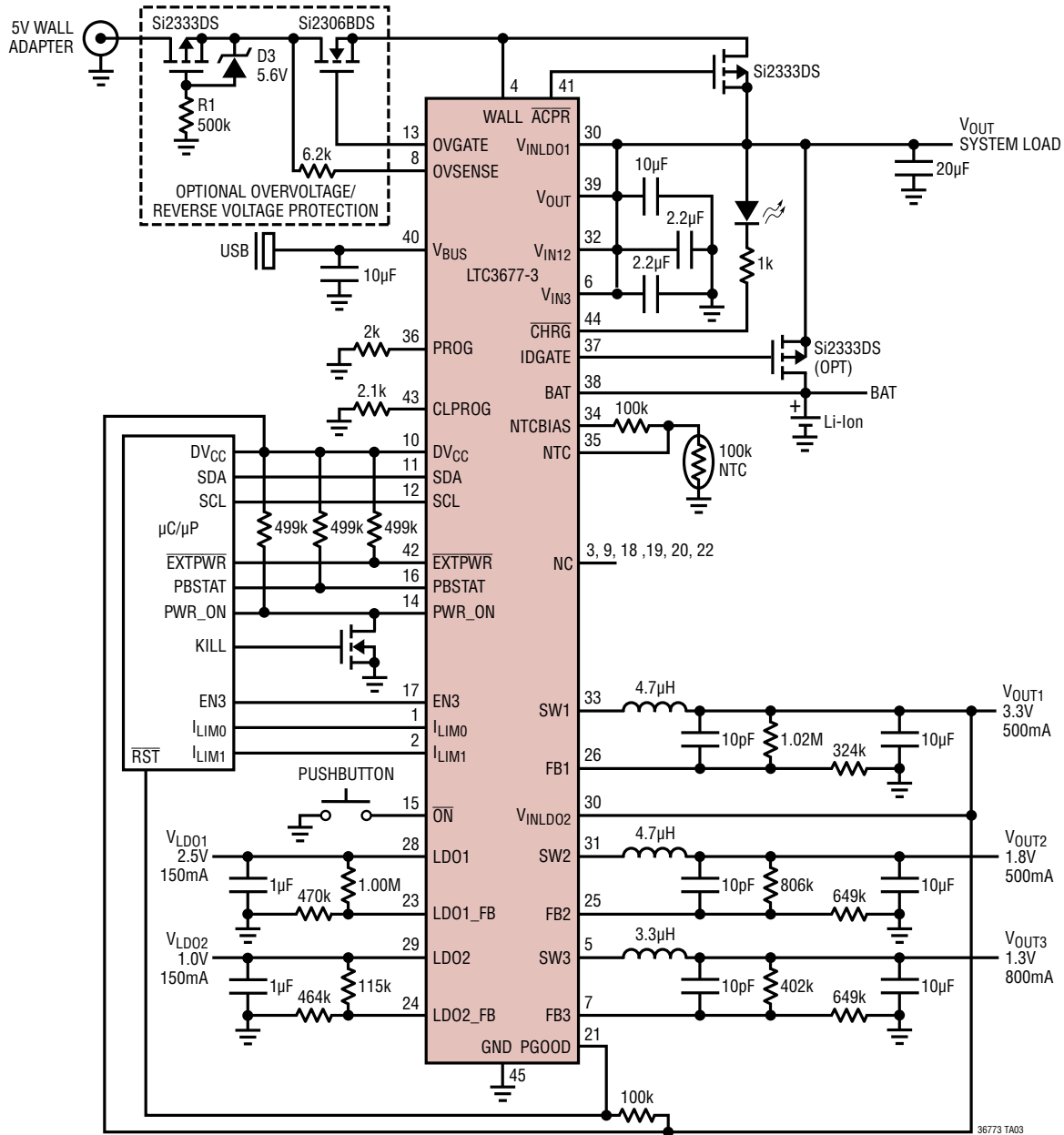

## RELATED PARTS

PART NUMBER	DESCRIPTION	COMMENTS
LTC3556	High Efficiency USB Power Manager Plus Dual Buck Plus Buck-Boost DC/DC PMIC	Two 400mA Synchronous Buck Regulators, One 1A Buck-Boost Regulator, 4mm × 5mm QFN28 Package.
LTC3557/ LTC3557-1	USB Power Manager with Li-Ion/Polymer Charger and Triple Synchronous Buck Converter	Linear Power Manager and Three Buck Regulators, 4mm × 4mm QFN28 Package, LTC3557-1 Version Has 4.1V Float Voltage.
LTC3577/ LTC3577-1	Highly Integrated Portable/Navigation PMIC	Linear Power Manager and Three Buck Regulators, 10-LED Boost Regulator, 2× 150mA LDOs, 4mm × 7mm QFN44 Package, LTC3577-1 Version Has 4.1V Float Voltage.

36773f