

1 FIGURE OF INSERTION

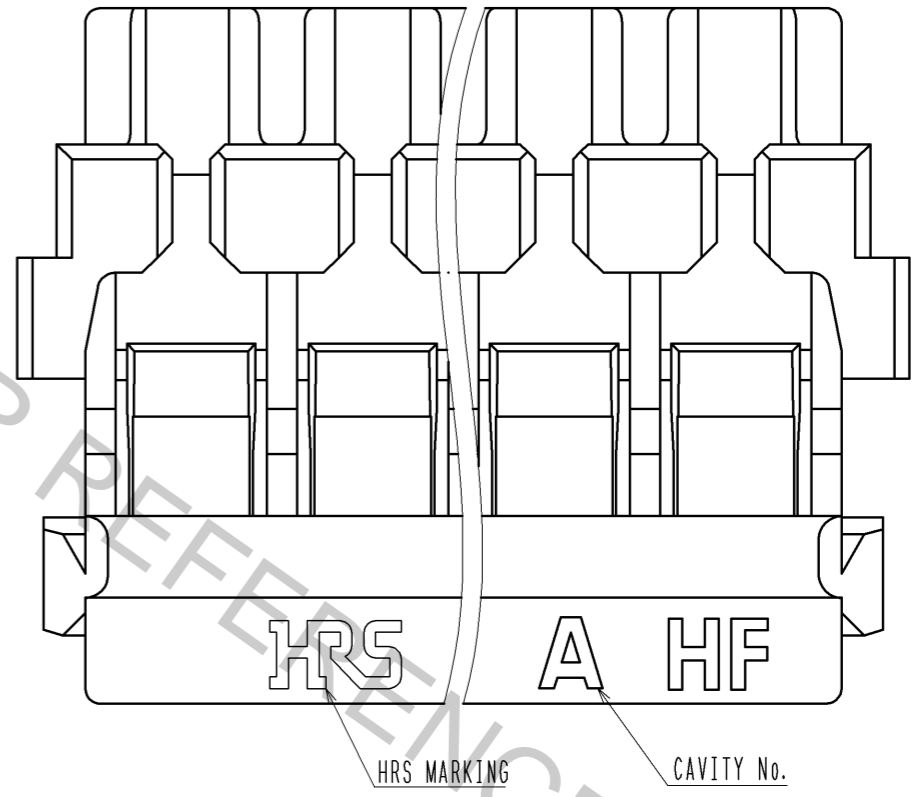
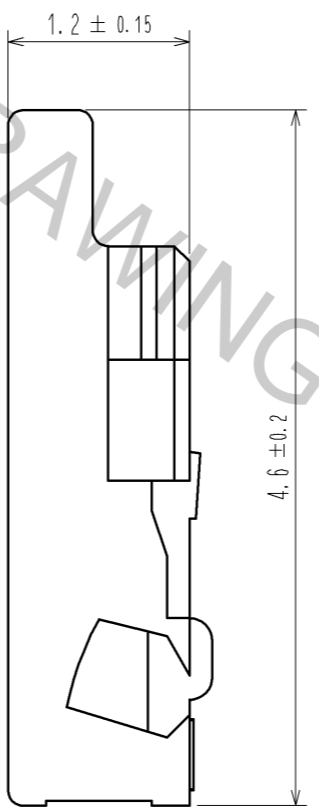
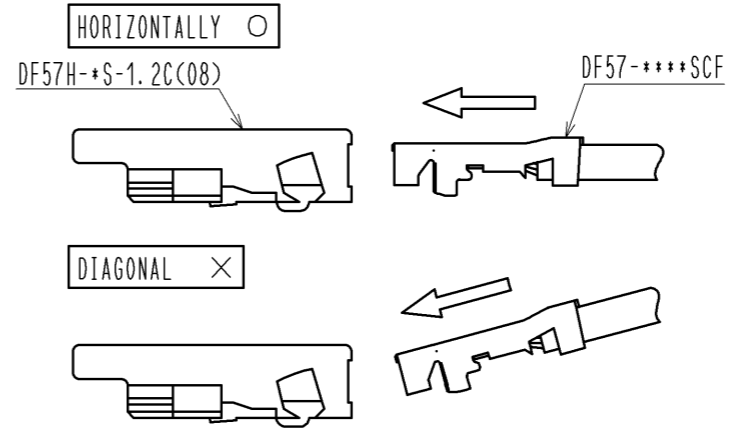

NOTE 1 AVOID ANGLED INSERTION OF CRIMP CONTACT(DF57-\*\*\*\*SCF) TO MAINTAIN PERFORMANCE RELIABILITY.

| CODE No.          | PART No.          | NUMBER OF CONTACTS | A   | B   | C    | D   | D    |
|-------------------|-------------------|--------------------|-----|-----|------|-----|------|
| CL666-0100-6-08   | DF57H-2S-1.2C(O8) | 2                  | 1.2 | 3.5 | 2.98 | 2.6 | 3.15 |
| CL666-0012-0-08   | DF57H-3S-1.2C(O8) | 3                  | 2.4 | 4.7 | 4.18 | 3.8 | 4.35 |
| △ CL666-0101-9-08 | DF57H-4S-1.2C(O8) | 4                  | 3.6 | 5.9 | 5.38 | 5.0 | 5.55 |
| △ CL666-0102-1-08 | DF57H-5S-1.2C(O8) | 5                  | 4.8 | 7.1 | 6.58 | 6.2 | 6.75 |
| △ CL666-0103-4-08 | DF57H-6S-1.2C(O8) | 6                  | 6.0 | 8.3 | 7.78 | 7.4 | 7.95 |

|                               |    |            |                           |                   |                         |
|-------------------------------|----|------------|---------------------------|-------------------|-------------------------|
| 部番                            | 材質 | 処理、備考      | 1                         | LCP               | UL94V-0, NATURAL(BEIGE) |
| UNITS mm                      |    | SCALE 20:1 | △の数 2                     | 訂正記事 DIS-H-008103 | 設計 TS. KUMAZAWA         |
| 承認: KI. AKIYAMA 12.11.21      |    |            | 検図: HK. UMEHARA 12.11.21  |                   |                         |
| 設計: TS. KUMAZAWA 12.11.21     |    |            | 製図: TS. KUMAZAWA 12.11.21 |                   |                         |
| HRS HIROSE ELECTRIC CO., LTD. |    |            | 図番: EDC3-349275-01        |                   |                         |
|                               |    |            | 製品名: DF57H-*S-1.2C(O8)    |                   |                         |
|                               |    |            | 製品コード: CL666-             |                   |                         |

# DF57 Series Mating / Unmating Operation Instruction

## Mating

① By positioning the convexity of the socket sides to the header concavity, align the centers of the socket and the header in pitch direction.

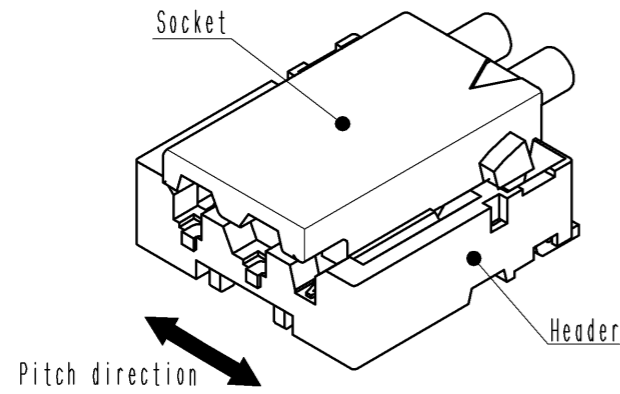

② Slightly press the socket down at cable side to tilted angle.

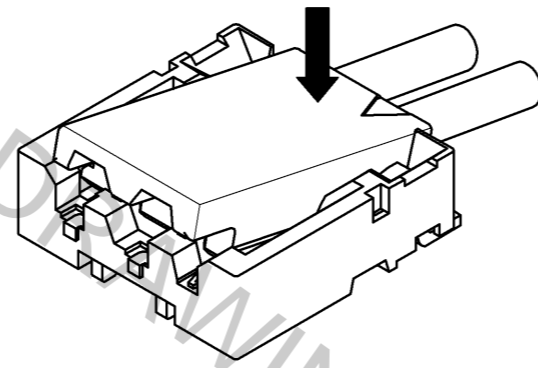

③ Press down at the lever side with stabilizing the cable side to insert. Mating completes.

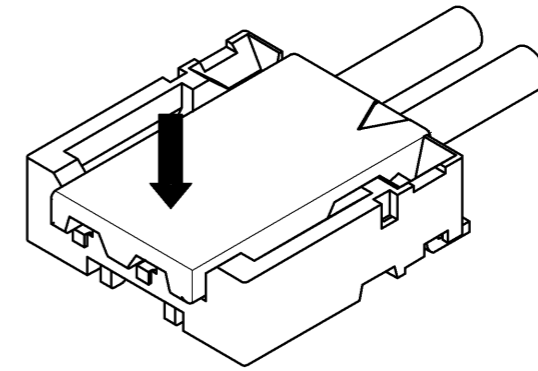

## Unmating

① Hook the lever with finger nail.

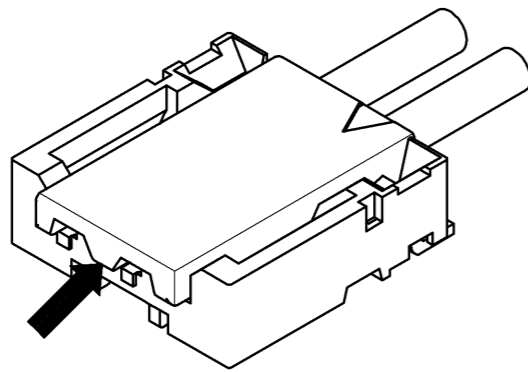

② Lift up to the upper direction and friction lock is released.

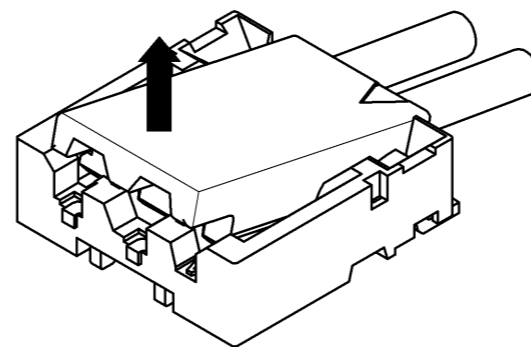

③ Lift up to the upper direction and positive lock is released. Removal completes.

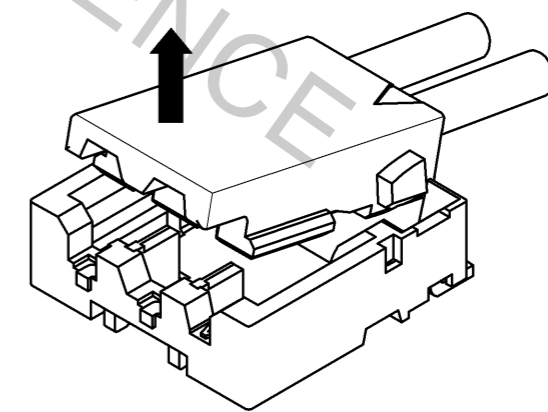

|            |             |                   |
|------------|-------------|-------------------|
| <b>HRS</b> | DRAWING NO. | EDC3-349275-01    |
|            | PART NO.    | DF57H-*S-1.2C<08> |
|            | CODE NO.    | CL666-            |
|            |             | 1/2               |