



**MICROCHIP**

---

**Audio Development Board  
User's Guide**

---

**Note the following details of the code protection feature on Microchip devices:**

- Microchip products meet the specification contained in their particular Microchip Data Sheet.
- Microchip believes that its family of products is one of the most secure families of its kind on the market today, when used in the intended manner and under normal conditions.
- There are dishonest and possibly illegal methods used to breach the code protection feature. All of these methods, to our knowledge, require using the Microchip products in a manner outside the operating specifications contained in Microchip's Data Sheets. Most likely, the person doing so is engaged in theft of intellectual property.
- Microchip is willing to work with the customer who is concerned about the integrity of their code.
- Neither Microchip nor any other semiconductor manufacturer can guarantee the security of their code. Code protection does not mean that we are guaranteeing the product as "unbreakable."

Code protection is constantly evolving. We at Microchip are committed to continuously improving the code protection features of our products. Attempts to break Microchip's code protection feature may be a violation of the Digital Millennium Copyright Act. If such acts allow unauthorized access to your software or other copyrighted work, you may have a right to sue for relief under that Act.

---

Information contained in this publication regarding device applications and the like is provided only for your convenience and may be superseded by updates. It is your responsibility to ensure that your application meets with your specifications. MICROCHIP MAKES NO REPRESENTATIONS OR WARRANTIES OF ANY KIND WHETHER EXPRESS OR IMPLIED, WRITTEN OR ORAL, STATUTORY OR OTHERWISE, RELATED TO THE INFORMATION, INCLUDING BUT NOT LIMITED TO ITS CONDITION, QUALITY, PERFORMANCE, MERCHANTABILITY OR FITNESS FOR PURPOSE. Microchip disclaims all liability arising from this information and its use. Use of Microchip devices in life support and/or safety applications is entirely at the buyer's risk, and the buyer agrees to defend, indemnify and hold harmless Microchip from any and all damages, claims, suits, or expenses resulting from such use. No licenses are conveyed, implicitly or otherwise, under any Microchip intellectual property rights.

**Trademarks**

The Microchip name and logo, the Microchip logo, dsPIC, KEELOQ, KEELOQ logo, MPLAB, PIC, PICmicro, PICSTART, PIC<sup>32</sup> logo, rPIC and UNI/O are registered trademarks of Microchip Technology Incorporated in the U.S.A. and other countries.

FilterLab, Hampshire, HI-TECH C, Linear Active Thermistor, MXDEV, MXLAB, SEEVAL and The Embedded Control Solutions Company are registered trademarks of Microchip Technology Incorporated in the U.S.A.

Analog-for-the-Digital Age, Application Maestro, CodeGuard, dsPICDEM, dsPICDEM.net, dsPICworks, dsSPEAK, ECAN, ECONOMONITOR, FanSense, HI-TIDE, In-Circuit Serial Programming, ICSP, Mindi, MiWi, MPASM, MPLAB Certified logo, MPLIB, MPLINK, mTouch, Omniscient Code Generation, PICC, PICC-18, PICDEM, PICDEM.net, PICKit, PICtail, REAL ICE, rLAB, Select Mode, Total Endurance, TSHARC, UniWinDriver, WiperLock and ZENA are trademarks of Microchip Technology Incorporated in the U.S.A. and other countries.

SQTP is a service mark of Microchip Technology Incorporated in the U.S.A.

All other trademarks mentioned herein are property of their respective companies.

© 2011, Microchip Technology Incorporated, Printed in the U.S.A., All Rights Reserved.

 Printed on recycled paper.

ISBN: 978-1-61341-200-8

*Microchip received ISO/TS-16949:2002 certification for its worldwide headquarters, design and wafer fabrication facilities in Chandler and Tempe, Arizona; Gresham, Oregon and design centers in California and India. The Company's quality system processes and procedures are for its PIC<sup>®</sup> MCUs and dsPIC<sup>®</sup> DSCs, KEELOQ<sup>®</sup> code hopping devices, Serial EEPROMs, microperipherals, nonvolatile memory and analog products. In addition, Microchip's quality system for the design and manufacture of development systems is ISO 9001:2000 certified.*

**QUALITY MANAGEMENT SYSTEM  
CERTIFIED BY DNV  
== ISO/TS 16949:2002 ==**

---

---

**Table of Contents**

---

---

<b>Preface</b> .....	<b>5</b>
<b>Chapter 1. Introduction</b>	
1.1 Overview .....	11
<b>Chapter 2. Hardware</b>	
2.1 Power Supply .....	13
2.2 Microcontroller .....	13
2.3 Audio Codec, Microphone and Audio Connections .....	13
2.4 Expansion Connector .....	14
2.5 TFT Display .....	14
2.6 USB Connectivity .....	14
2.7 UART Connectivity .....	14
2.8 User LEDs and Switches .....	14
<b>Appendix A. Schematics and Board Layout</b>	
A.1 Audio Development Board Schematics .....	15
A.2 Audio Development Board Layout .....	20
<b>Worldwide Sales and Service</b> .....	<b>22</b>

# Audio Development Board User's Guide

---

NOTES:

---

---

## Preface

---

---

### NOTICE TO CUSTOMERS

All documentation becomes dated, and this manual is no exception. Microchip tools and documentation are constantly evolving to meet customer needs, so some actual dialogs and/or tool descriptions may differ from those in this document. Please refer to our web site ([www.microchip.com](http://www.microchip.com)) to obtain the latest documentation available.

Documents are identified with a “DS” number. This number is located on the bottom of each page, in front of the page number. The numbering convention for the DS number is “DSXXXXA”, where “XXXX” is the document number and “A” is the revision level of the document.

For the most up-to-date information on development tools, see the MPLAB® IDE on-line help. Select the Help menu, and then Topics to open a list of available on-line help files.

## INTRODUCTION

This chapter contains general information that will be useful to know before using the Audio Development Board. Items discussed in this chapter include:

- [Document Layout](#)
- [Conventions Used in this Guide](#)
- [Recommended Reading](#)
- [The Microchip Web Site](#)
- [Development Systems Customer Change Notification Service](#)
- [Customer Support](#)
- [Document Revision History](#)

## DOCUMENT LAYOUT

This document describes how to use the Audio Development Board as a development tool to design high-quality audio development platforms.

This user's guide is composed of the following:

- **Chapter 1. “Introduction”** – provides an overview of the Audio Development Board, highlighting its features and uses.
- **Chapter 2. “Hardware”** – provides the hardware descriptions of the Audio Development Board.
- **Appendix A. “Schematics and Board Layout”** – provides a detailed schematic and a board layout diagram of the Audio Development Board.

# Audio Development Board User's Guide

---

## CONVENTIONS USED IN THIS GUIDE

This manual uses the following documentation conventions:

### DOCUMENTATION CONVENTIONS

Description	Represents	Examples
<b>Arial font:</b>		
Italic characters	Referenced books	<i>MPLAB<sup>®</sup> IDE User's Guide</i>
	Emphasized text	...is the <i>only</i> compiler...
Initial caps	A window	the Output window
	A dialog	the Settings dialog
	A menu selection	select Enable Programmer
Quotes	A field name in a window or dialog	"Save project before build"
Underlined, italic text with right angle bracket	A menu path	<u><i>File&gt;Save</i></u>
Bold characters	A dialog button	Click <b>OK</b>
	A tab	Click the <b>Power</b> tab
Text in angle brackets < >	A key on the keyboard	Press <Enter>, <F1>
<b>Courier New font:</b>		
Plain Courier New	Sample source code	<code>#define START</code>
	Filenames	<code>autoexec.bat</code>
	File paths	<code>C:\mcc18\h</code>
	Keywords	<code>_asm, _endasm, static</code>
	Command-line options	<code>-Opa+, -Opa-</code>
	Bit values	<code>0, 1</code>
	Constants (in source code)	<code>0xFF, 'A'</code>
<i>Italic Courier New</i>	A variable argument	<i>file.o</i> , where <b>file</b> can be any valid filename
Square brackets [ ]	Optional arguments	<code>mcc18 [options] file [options]</code>
Curly brackets and pipe character: {   }	Choice of mutually exclusive arguments; an OR selection	<code>errorlevel {0 1}</code>
Ellipses...	Replaces repeated text	<code>var_name [, var_name...]</code>
	Represents code supplied by user	<code>void main (void) { ... }</code>

## RECOMMENDED READING

This user's guide describes how to use the Audio Development Board. The following Microchip documents are available and recommended as supplemental reference resources.

### **MPLAB® C Compiler for PIC24 MCUs and dsPIC® DSCs User's Guide (DS51284)**

This document helps you use Microchip's 16-bit C compilers to develop your application. The compilers are the MPLAB C Compiler for dsPIC DSCs and PIC24 MCUs, the MPLAB C Compiler for dsPIC DSCs (subset of the first), and the MPLAB C Compiler for PIC24 MCUs (subset of the first). These compilers are GNU-based language tools, based on source code from the Free Software Foundation (FSF). For more information about FSF, see [www.fsf.org](http://www.fsf.org).

### **MPLAB® Assembler, Linker and Utilities for PIC24 MCUs and dsPIC® DSCs User's Guide (DS51317)**

This document helps you use Microchip Technology's 16-bit language tools based on GNU technology. The language tools discussed are the MPLAB Assembler for dsPIC DSCs and PIC24 MCUs, MPLAB Object Linker for dsPIC DSCs and PIC24 MCUs, MPLAB Archiver/Librarian for dsPIC DSCs and PIC24 MCUs and other 16-bit device utilities.

### **MPLAB® C Compiler for PIC32 User's Guide (DS51686)**

This document, formerly the "*MPLAB C32 C Compiler for PIC32 User's Guide*", details the use of Microchip's MPLAB C Compiler for PIC32 to develop an application.

### **MPLAB® IDE User's Guide (DS51519)**

Consult this document for more information pertaining to the installation and implementation of the MPLAB IDE software, as well as the MPLAB Editor and MPLAB SIM Simulator software that are included with it.

### **Universal Serial Bus Specification and Associated Documents**

The Universal Serial Bus is defined by the USB 2.0 specification and its associated supplements and class-specific documents. These documents are available from the USB Implementers Forum. See their website at: <http://www.usb.org>

## ADDITIONAL INFORMATION

iPod is a registered trademark of Apple, Inc., registered in the U.S. and other countries.

# Audio Development Board User's Guide

---

## THE MICROCHIP WEB SITE

Microchip provides online support via our web site at: <http://www.microchip.com>. This web site makes files and information easily available to customers. Accessible by most Internet browsers, the web site contains the following information:

- **Product Support** – Data sheets and errata, application notes and sample programs, design resources, user's guides and hardware support documents, latest software releases and archived software
- **General Technical Support** – Frequently Asked Questions (FAQs), technical support requests, online discussion groups, Microchip consultant program member listings
- **Business of Microchip** – Product selector and ordering guides, latest Microchip press releases, listings of seminars and events; and listings of Microchip sales offices, distributors and factory representatives

## DEVELOPMENT SYSTEMS CUSTOMER CHANGE NOTIFICATION SERVICE

Microchip's customer notification service helps keep customers current on Microchip products. Subscribers will receive e-mail notification whenever there are changes, updates, revisions or errata related to a specified product family or development tool of interest.

To register, access the Microchip web site at <http://www.microchip.com>, click **Customer Change Notification** and follow the registration instructions.

The Development Systems product group categories are:

- **Compilers** – The latest information on Microchip C compilers and other language tools. These include the MPLAB<sup>®</sup> C compiler; MPASM<sup>™</sup> and MPLAB 16-bit assemblers; MPLINK<sup>™</sup> and MPLAB 16-bit object linkers; and MPLIB<sup>™</sup> and MPLAB 16-bit object librarians.
- **Emulators** – The latest information on the Microchip MPLAB<sup>®</sup> REAL ICE<sup>™</sup> In-Circuit Emulator.
- **In-Circuit Debuggers** – The latest information on the Microchip in-circuit debugger, MPLAB ICD 3.
- **MPLAB IDE** – The latest information on Microchip MPLAB IDE, the Windows<sup>®</sup> Integrated Development Environment for development systems tools. This list is focused on the MPLAB IDE, MPLAB SIM simulator, MPLAB IDE Project Manager and general editing and debugging features.
- **Programmers** – The latest information on Microchip programmers. These include the MPLAB PM3 device programmer and the PICKit<sup>™</sup> 3 development programmers.

## CUSTOMER SUPPORT

Users of Microchip products can receive assistance through several channels:

- Distributor or Representative
- Local Sales Office
- Field Application Engineer (FAE)
- Technical Support

Customers should contact their distributor, representative or field application engineer (FAE) for support. Local sales offices are also available to help customers. A listing of sales offices and locations is included in the back of this document.

Technical support is available through our web site at: <http://microchip.com/support>



## DOCUMENT REVISION HISTORY

### **Revision A (May 2011)**

This is the initial release of the Audio Development Board User's Guide.

# Audio Development Board User's Guide

---

NOTES:

## Chapter 1. Introduction

Thank you for purchasing an Audio Development Board from Microchip Technology Inc. The Audio Development Board showcases a 16/32-bit audio development platform with a true 24-bit audio codec. In addition, the board also showcases the performance of PIC32 MCU/dsPIC33E DSC for complex audio algorithms.

### 1.1 OVERVIEW

The features of the Audio Development Board are:

- High-performance MCU
- Wolfson WM8960 audio codec with up to 48 kHz sampling rate and up to 24-bit resolution
- Headphone out, Line-in jacks, and an on-board MIC
- TFT color display with 220x176 resolution
- PICTail™ Plus Connector
- General purpose user switches and LEDs

Figure 1-1 shows the Audio Development Board, which is annotated to show the main components. Each component is described in detail in Table 1-1.

**FIGURE 1-1: AUDIO DEVELOPMENT BOARD**

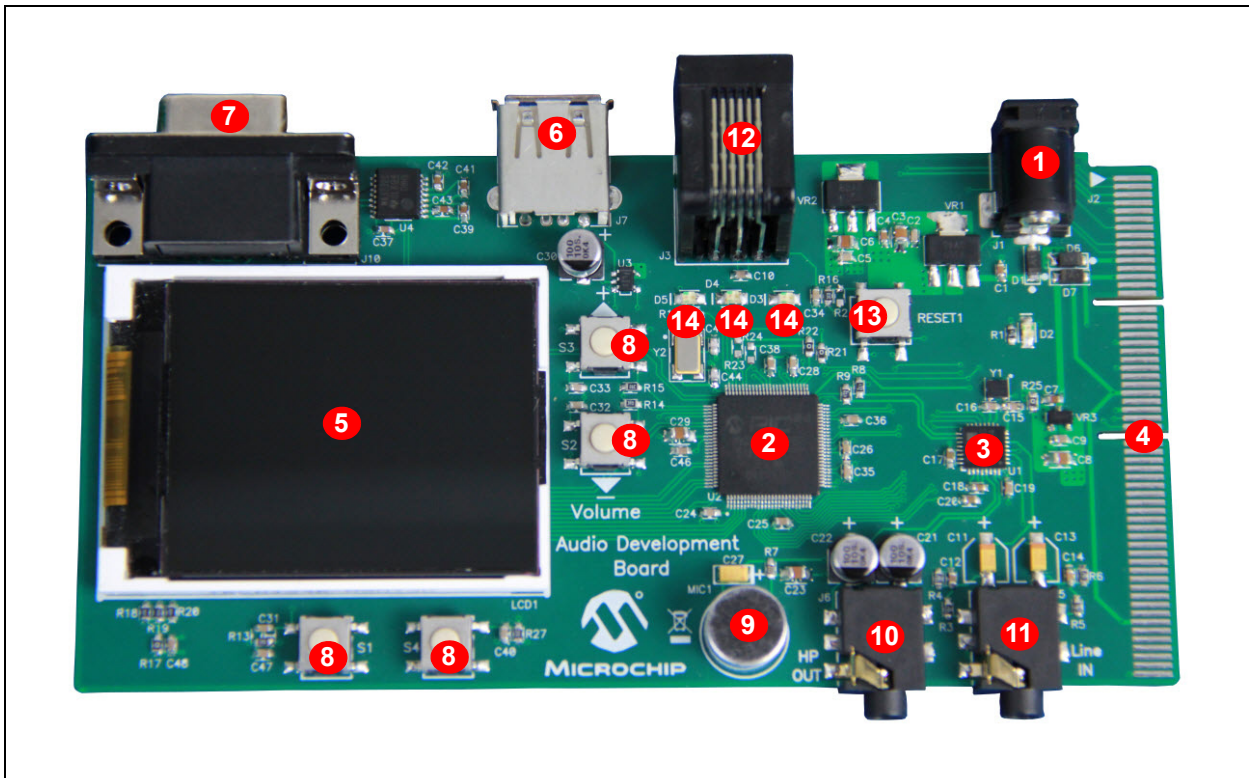

# Audio Development Board User's Guide

---

**TABLE 1-1: AUDIO DEVELOPMENT BOARD COMPONENT DESCRIPTIONS**

Item Number	Component Label	Description
1	J1	9V DC power connector.
2	U2	Microcontroller.
3	U1	Wolfson WM8960 audio codec.
4	J2	PICtail Plus Connector for iPod® PICtail™ Plus Board.
5	LCD1	2-inch (220x176) TFT display.
6	J7	USB interface connector.
7	J10	RS-232 serial UART connector.
8	S1, S2, S3, S4	General purpose user application switches.
9	MIC1	Condenser microphone.
10	HP OUT	3.5 mm stereo headphone socket.
11	Line IN	Line input socket.
12	J3	RJ-45 debugger connector.
13	RESET1	Device Reset switch.
14	D3, D4, D5	General purpose user LEDs.

Refer to [Chapter 2. “Hardware”](#) for detailed hardware descriptions

---

---

## Chapter 2. Hardware

---

---

This chapter provides a functional overview of the hardware used in the Audio Development Board and identifies the major hardware components.

Topics covered include:

- [Power Supply](#)
- [Microcontroller](#)
- [Audio Codec, Microphone and Audio Connections](#)
- [PICtail™ Plus Connector](#)
- [TFT Display](#)
- [USB Connectivity](#)
- [UART Connectivity](#)
- [User LEDs and Switches](#)

### 2.1 POWER SUPPLY

Power can be supplied to the Audio Development Board through the DC connector (J1). By connecting a 9V power supply to the DC connector, the Audio Development Board and the expansion connector will receive the proper voltages.

#### CAUTION

Care should be exercised while working with headphones or speakers. Exposure to high volumes can result in hearing damage. The use of headphones or speakers with built-in volume control is recommended.

### 2.2 MICROCONTROLLER

The microcontroller (U2) on-board the Audio Development Board is a 16/32-bit, high-performance microcontroller (MCU). The clock requirement is met via the 8 MHz external crystal oscillator (Y2). The device can be placed in Reset by activating the RESET1 switch.

A debugger or programmer such as MPLAB® REAL ICE™ In-Circuit Emulator or ICD 3 can be used via the RJ-45 (J3) connector. The debugging interface is implemented via the ICSP™ protocol and the external debugger is connected to the ICSP socket (J3).

# Audio Development Board User's Guide

---

## 2.3 AUDIO CODEC, MICROPHONE AND AUDIO CONNECTIONS

The audio codec (U1) is a Wolfson WM8960. The codec is of hi-fi quality with up to 24-bit resolution. The sampling rates supported are between 8 kHz to 48 kHz and includes an on-chip flexible PLL. The codec has a built-in headphone driver and a stereo Class D speaker driver. In addition, it has low-power consumption and offers a small foot print. On 32-bit microcontroller, the codec data interface is handled through the SPI module in Framed SPI mode. On 16-bit microcontroller, the codec data interface is handled through the DCI module. The control registers of the codec are configured over the I<sup>2</sup>C interface. The codec external clock is provided by a 12 MHz crystal oscillator.

The condenser microphone (MIC1) is available on the board for capturing audio. The microphone bias voltage is provided directly by the codec and is connected via Line Input 1 of the codec. The microphone bias voltage level and sensitivity are controlled via the codec registers. The microphone signal is presented as a mono signal to the application.

The line-in jack (Line IN) is available to interface to audio signal sources (such as CD players and musical instruments) that use line level outputs. The line input signal is a stereo signal and is connected to Left Input 2 and Right Input 2 of the codec.

**Note:** The maximum line input signal level should not exceed 0.5Vrms on differential and 1Vrms on single-ended input.

The Headphone jack (HP OUT) is a 3.5 mm stereo socket that connects to the codec headphone amplifier, with the headphone signal output as a true stereo signal. Any commercially available headphone can be connected to the headphone jack. The headphone volume and the headphone input signal are configurable via the codec registers. The codec outputs a maximum of 20 mW into a 32 Ohm headphone.

## 2.4 PICTail™ PLUS CONNECTOR

The expansion connector (J2) on the Audio Development Board can be used to enable Made for iPod (MFi) features for an iPod® PICTail Plus board. The PICTail Plus connector is not compatible with any other PICTail Plus Daughter boards.

## 2.5 TFT DISPLAY

The Audio Development Board has a 2 inch TFT display (LCD1) with a resolution of 220x176 for a maximum of 262K colors. The display is controlled by a chip-on-glass OTM2201A display controller. The display controller requires 8-bit parallel interface. The Parallel Master Port (PMP) on the MCU is used to interface to the display controller.

## 2.6 USB CONNECTIVITY

The Audio Development Board features USB Host support (J7). This connector allows applications to interface to USB devices such as a USB Thumb Drive, USB mouse, and so on. The USB module on the MCU provides the required USB Host functionality. A 5V switch controlled by the MCU controls the power supply to the attached USB device.

## 2.7 UART CONNECTIVITY

The RS-232 Serial port (J10) provides a general purpose serial communication port for application use. The MAX3232CUE (U4) RS-232 transceiver provides the required translation level and connects to a UART on the MCU (U2).

## 2.8 USER LEDS AND SWITCHES

The general purpose LEDs, D3, D4, and D5, are available for application use. The LEDs are connected to the MCU (U2) output ports. Setting the port high will activate the LED.

The general purpose push button switches S1, S2, S3, and S4, are available for application use. All four switches are connected to the MCU input ports. Activating a switch will cause the port line to pull low.

**Note:** Switches S2 and S3 are marked on the board as controlling volume; however, these switches *do not* control the volume of the codec (U1) DAC directly. The codec DAC volume is controlled by the on-board device (U2).

# Audio Development Board User's Guide

---

NOTES:



**Appendix A. Schematics and Board Layout**

**A.1 AUDIO DEVELOPMENT BOARD SCHEMATICS**

**FIGURE A-1: DISPLAY CIRCUIT**

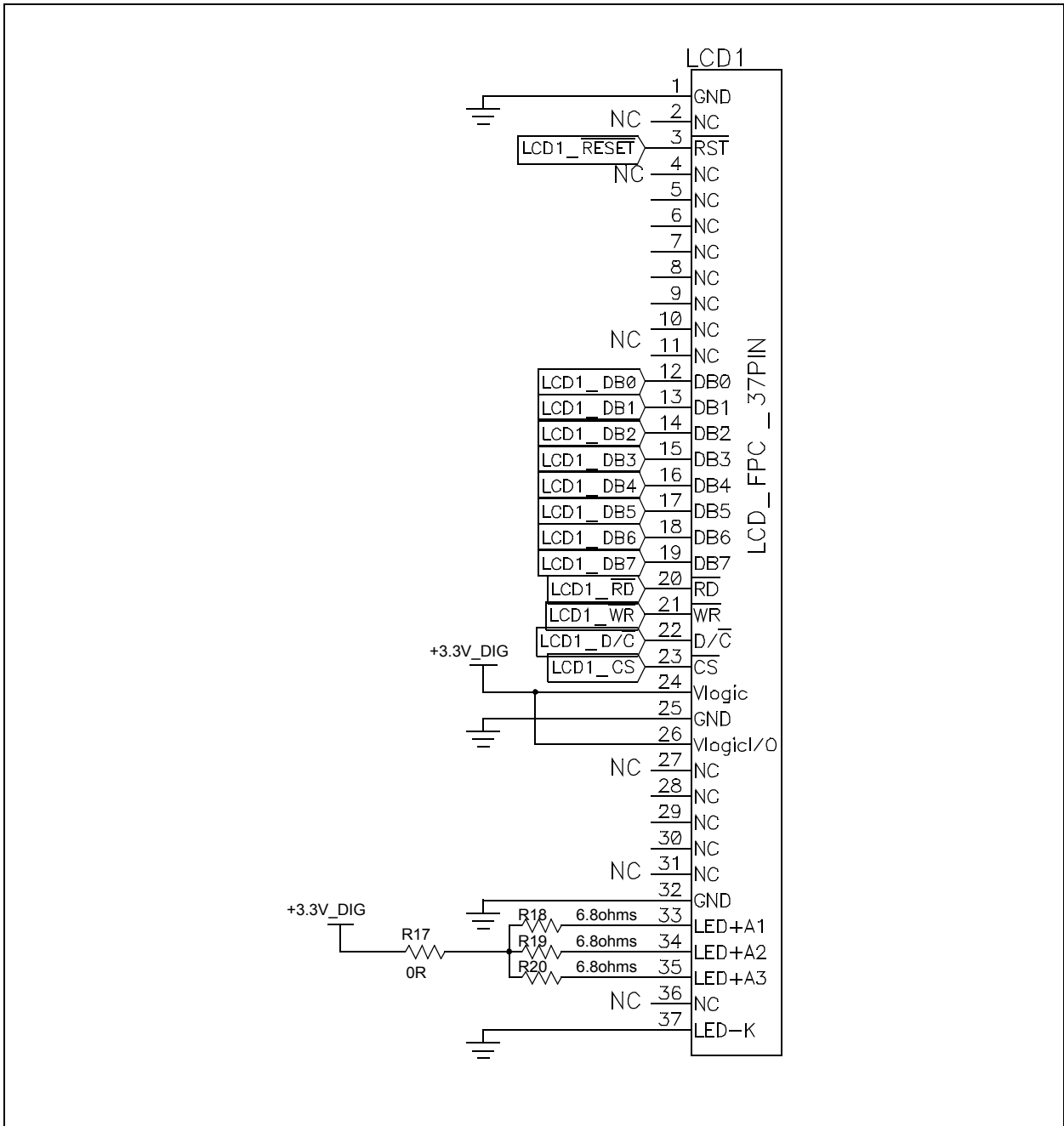

FIGURE A-2: AUDIO CIRCUIT

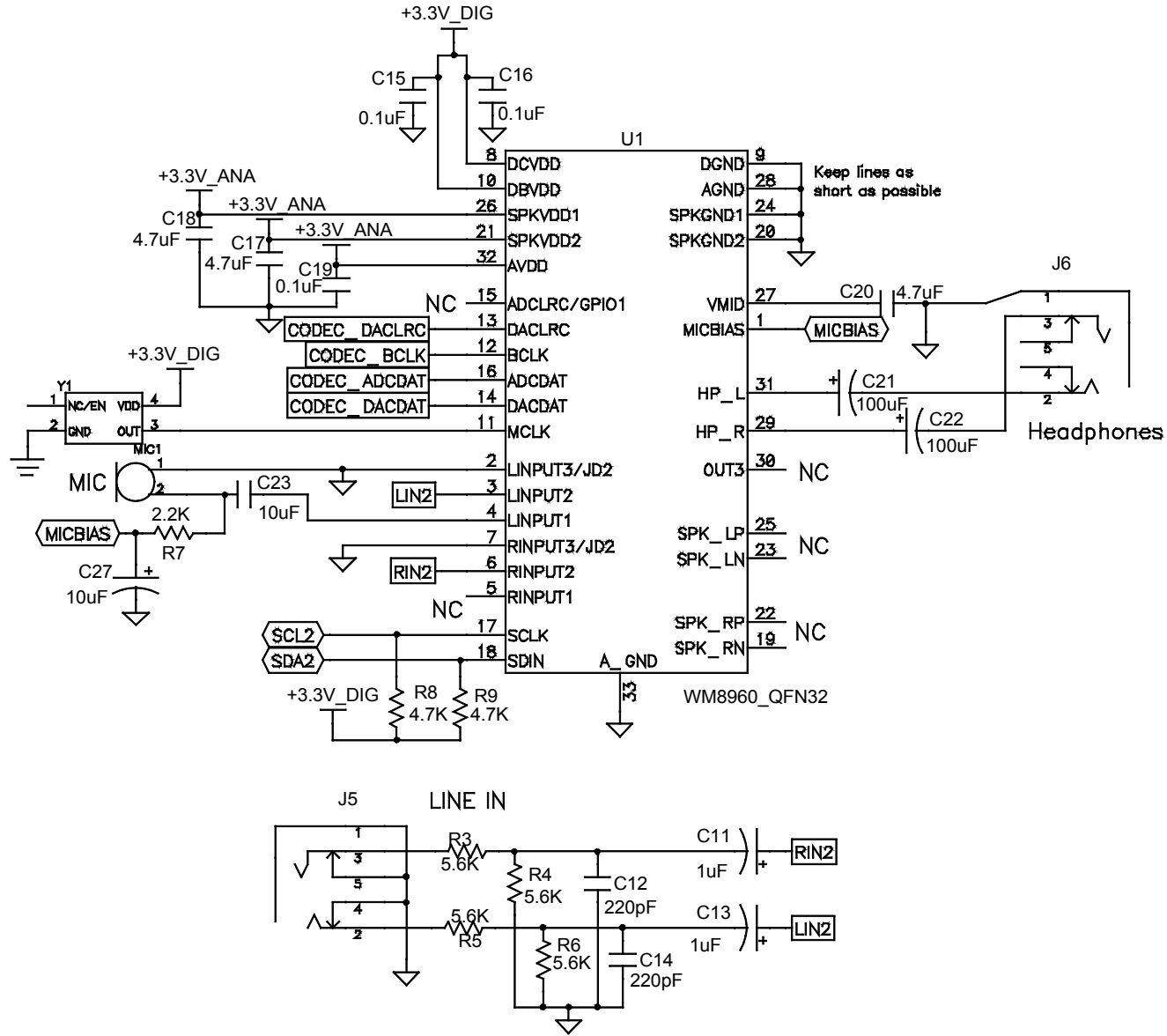

FIGURE A-3: MICROCONTROLLER AND USB CIRCUITS

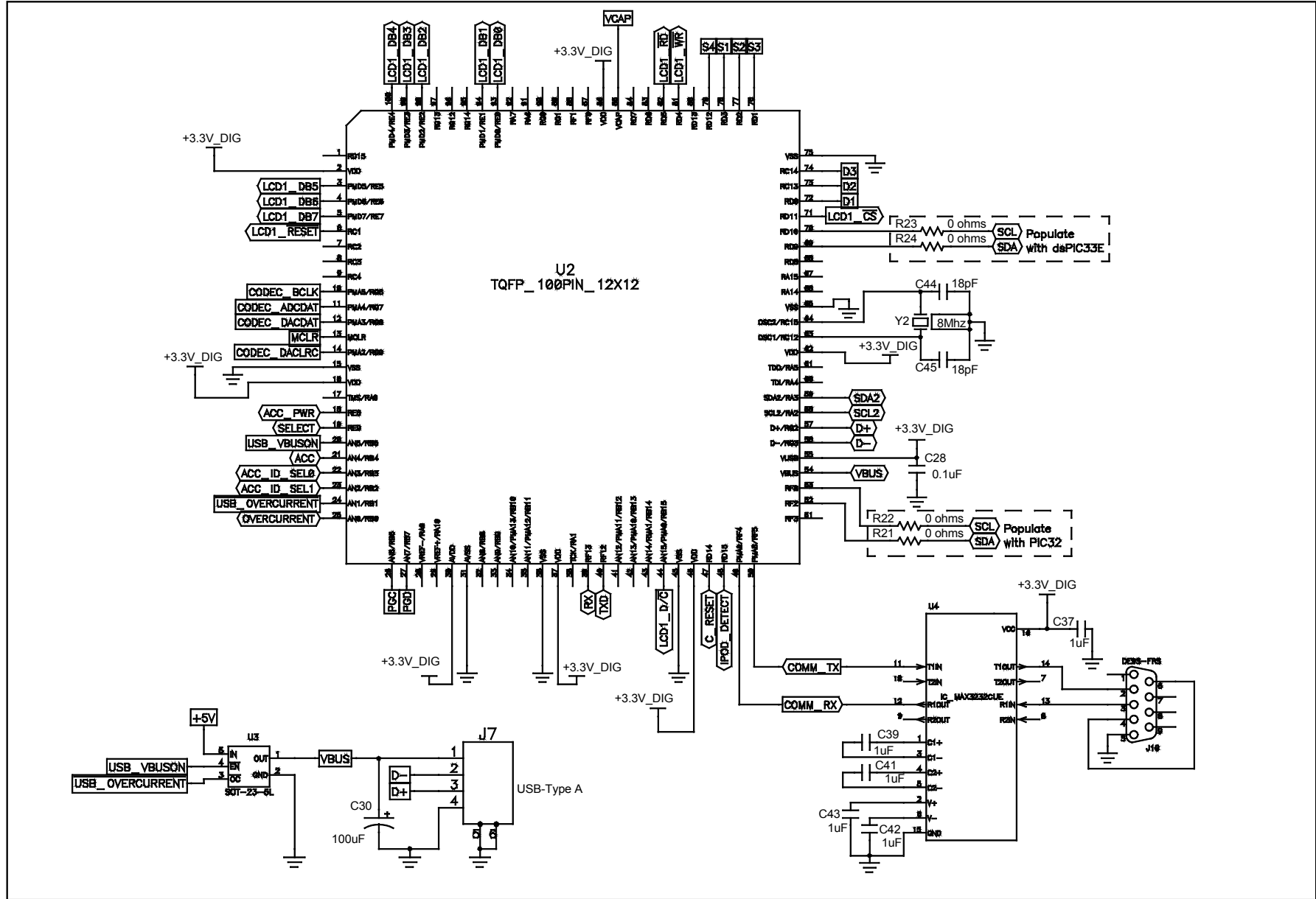
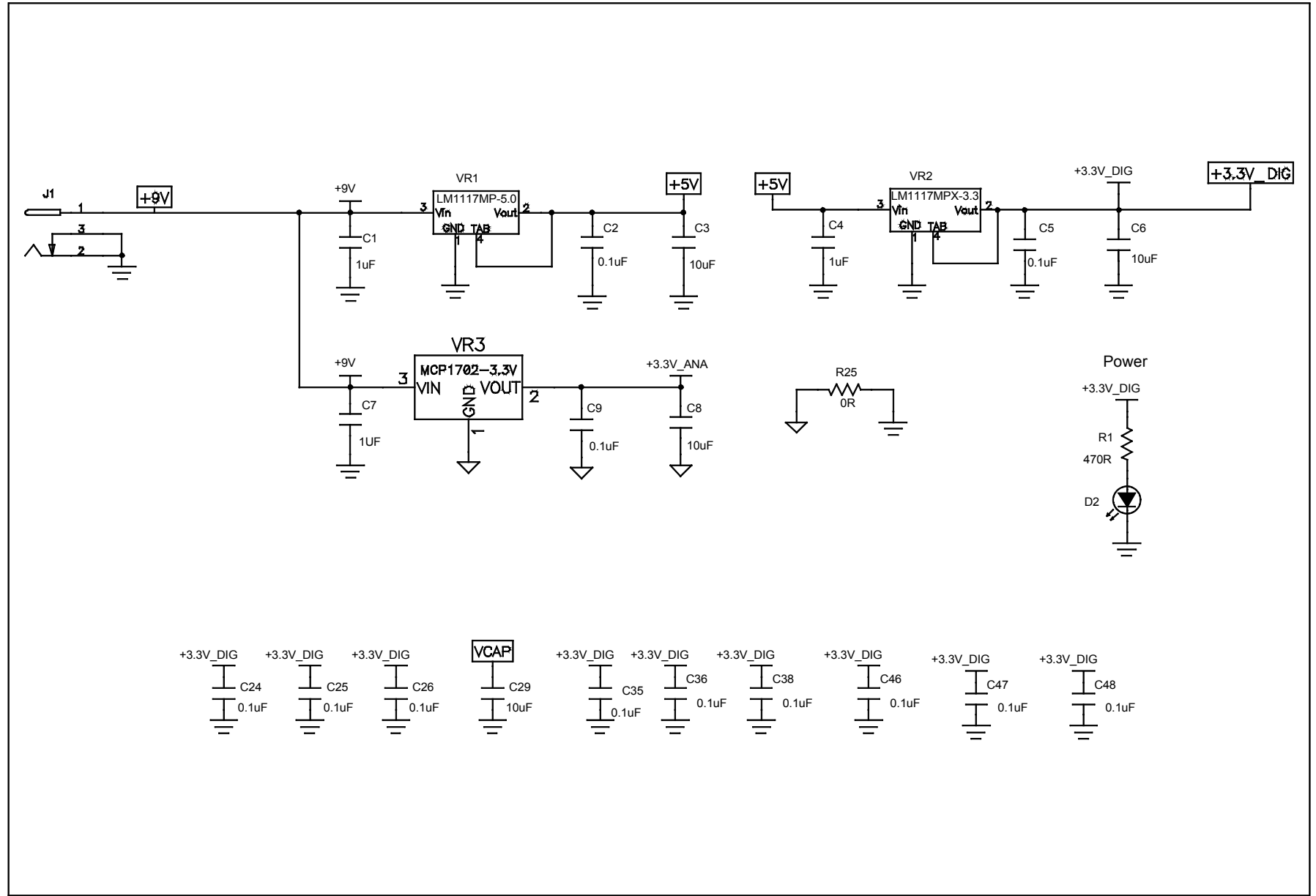
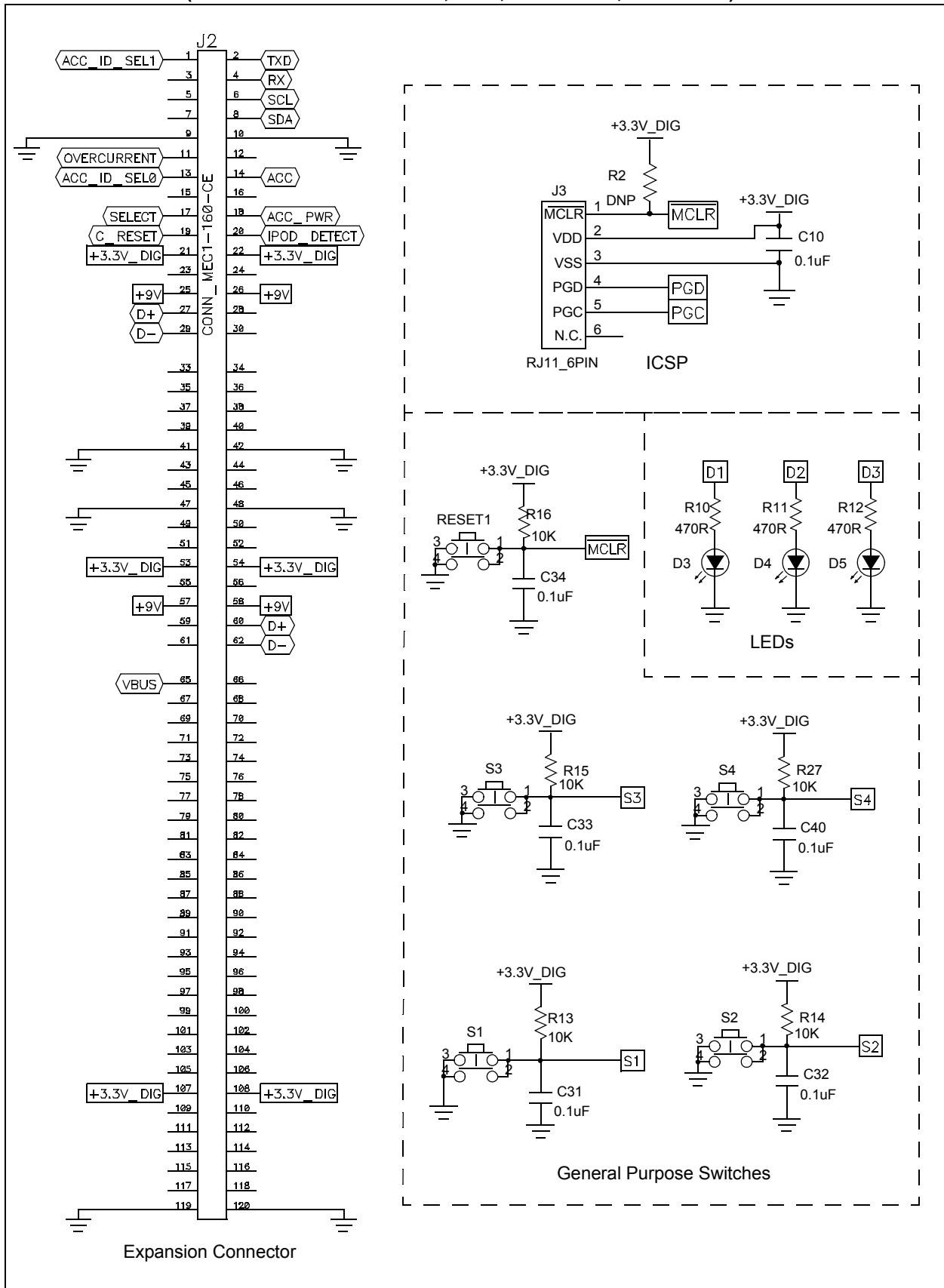

FIGURE A-4: POWER CIRCUITS



# Schematics and Board Layout

**FIGURE A-5: COMMUNICATION CIRCUITS  
(EXPANSION CONNECTOR, ICSP, SWITCHES, AND LEDs)**



## A.2 AUDIO DEVELOPMENT BOARD LAYOUT

FIGURE A-6: BOARD LAYOUT (TOP)

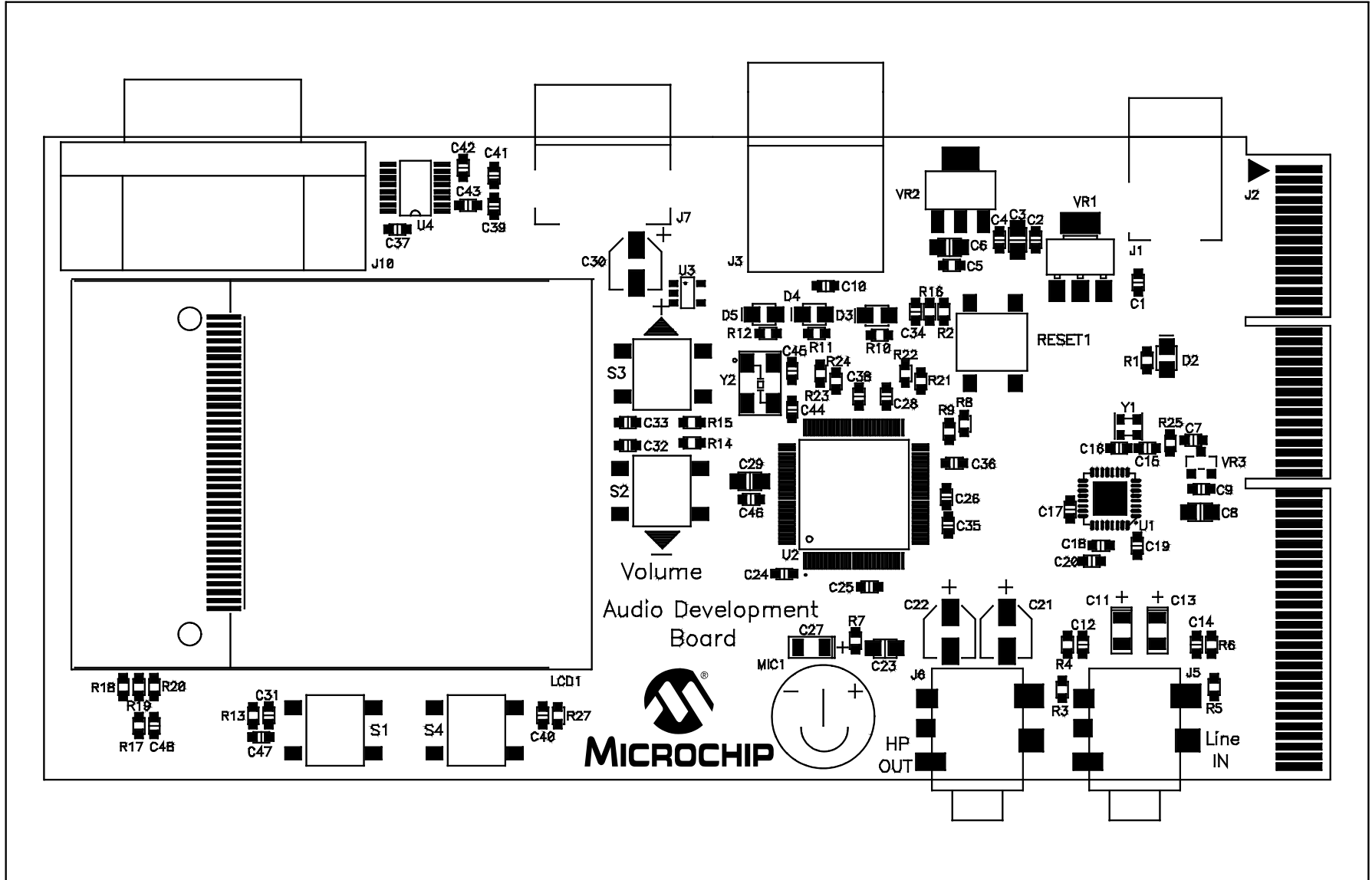

---

---

**NOTES:**



# MICROCHIP

## Worldwide Sales and Service

### AMERICAS

**Corporate Office**  
2355 West Chandler Blvd.  
Chandler, AZ 85224-6199  
Tel: 480-792-7200  
Fax: 480-792-7277  
Technical Support:  
<http://www.microchip.com/support>

Web Address:  
[www.microchip.com](http://www.microchip.com)

**Atlanta**  
Duluth, GA  
Tel: 678-957-9614  
Fax: 678-957-1455

**Boston**  
Westborough, MA  
Tel: 774-760-0087  
Fax: 774-760-0088

**Chicago**  
Itasca, IL  
Tel: 630-285-0071  
Fax: 630-285-0075

**Cleveland**  
Independence, OH  
Tel: 216-447-0464  
Fax: 216-447-0643

**Dallas**  
Addison, TX  
Tel: 972-818-7423  
Fax: 972-818-2924

**Detroit**  
Farmington Hills, MI  
Tel: 248-538-2250  
Fax: 248-538-2260

**Indianapolis**  
Noblesville, IN  
Tel: 317-773-8323  
Fax: 317-773-5453

**Los Angeles**  
Mission Viejo, CA  
Tel: 949-462-9523  
Fax: 949-462-9608

**Santa Clara**  
Santa Clara, CA  
Tel: 408-961-6444  
Fax: 408-961-6445

**Toronto**  
Mississauga, Ontario,  
Canada  
Tel: 905-673-0699  
Fax: 905-673-6509

### ASIA/PACIFIC

**Asia Pacific Office**  
Suites 3707-14, 37th Floor  
Tower 6, The Gateway  
Harbour City, Kowloon  
Hong Kong  
Tel: 852-2401-1200  
Fax: 852-2401-3431

**Australia - Sydney**  
Tel: 61-2-9868-6733  
Fax: 61-2-9868-6755

**China - Beijing**  
Tel: 86-10-8569-7000  
Fax: 86-10-8528-2104

**China - Chengdu**  
Tel: 86-28-8665-5511  
Fax: 86-28-8665-7889

**China - Chongqing**  
Tel: 86-23-8980-9588  
Fax: 86-23-8980-9500

**China - Hangzhou**  
Tel: 86-571-2819-3180  
Fax: 86-571-2819-3189

**China - Hong Kong SAR**  
Tel: 852-2401-1200  
Fax: 852-2401-3431

**China - Nanjing**  
Tel: 86-25-8473-2460  
Fax: 86-25-8473-2470

**China - Qingdao**  
Tel: 86-532-8502-7355  
Fax: 86-532-8502-7205

**China - Shanghai**  
Tel: 86-21-5407-5533  
Fax: 86-21-5407-5066

**China - Shenyang**  
Tel: 86-24-2334-2829  
Fax: 86-24-2334-2393

**China - Shenzhen**  
Tel: 86-755-8203-2660  
Fax: 86-755-8203-1760

**China - Wuhan**  
Tel: 86-27-5980-5300  
Fax: 86-27-5980-5118

**China - Xian**  
Tel: 86-29-8833-7252  
Fax: 86-29-8833-7256

**China - Xiamen**  
Tel: 86-592-2388138  
Fax: 86-592-2388130

**China - Zhuhai**  
Tel: 86-756-3210040  
Fax: 86-756-3210049

### ASIA/PACIFIC

**India - Bangalore**  
Tel: 91-80-3090-4444  
Fax: 91-80-3090-4123

**India - New Delhi**  
Tel: 91-11-4160-8631  
Fax: 91-11-4160-8632

**India - Pune**  
Tel: 91-20-2566-1512  
Fax: 91-20-2566-1513

**Japan - Yokohama**  
Tel: 81-45-471- 6166  
Fax: 81-45-471-6122

**Korea - Daegu**  
Tel: 82-53-744-4301  
Fax: 82-53-744-4302

**Korea - Seoul**  
Tel: 82-2-554-7200  
Fax: 82-2-558-5932 or  
82-2-558-5934

**Malaysia - Kuala Lumpur**  
Tel: 60-3-6201-9857  
Fax: 60-3-6201-9859

**Malaysia - Penang**  
Tel: 60-4-227-8870  
Fax: 60-4-227-4068

**Philippines - Manila**  
Tel: 63-2-634-9065  
Fax: 63-2-634-9069

**Singapore**  
Tel: 65-6334-8870  
Fax: 65-6334-8850

**Taiwan - Hsin Chu**  
Tel: 886-3-6578-300  
Fax: 886-3-6578-370

**Taiwan - Kaohsiung**  
Tel: 886-7-213-7830  
Fax: 886-7-330-9305

**Taiwan - Taipei**  
Tel: 886-2-2500-6610  
Fax: 886-2-2508-0102

**Thailand - Bangkok**  
Tel: 66-2-694-1351  
Fax: 66-2-694-1350

### EUROPE

**Austria - Wels**  
Tel: 43-7242-2244-39  
Fax: 43-7242-2244-393

**Denmark - Copenhagen**  
Tel: 45-4450-2828  
Fax: 45-4485-2829

**France - Paris**  
Tel: 33-1-69-53-63-20  
Fax: 33-1-69-30-90-79

**Germany - Munich**  
Tel: 49-89-627-144-0  
Fax: 49-89-627-144-44

**Italy - Milan**  
Tel: 39-0331-742611  
Fax: 39-0331-466781

**Netherlands - Drunen**  
Tel: 31-416-690399  
Fax: 31-416-690340

**Spain - Madrid**  
Tel: 34-91-708-08-90  
Fax: 34-91-708-08-91

**UK - Wokingham**  
Tel: 44-118-921-5869  
Fax: 44-118-921-5820

05/02/11