

REV. NO.		REVISIONS			
NO.	DATE	DESCRIPTION	DATE	BY	APPROV.
CM 53	J	REV & REDWN PER EC 0G1B-0252-98	8-19-98	BL	RS

- PARTS COMPLY TO AMP SOLDERABILITY SPECIFICATION 109-11-3.
- CIRCUIT IDENTIFICATION CHARACTERS ARE ADJACENT TO THE INDICATED CAVITIES, BUT LOCATION AND ORIENTATION MAY DIFFER FROM PRINT.
- DIMENSIONS IN BRACKETS ARE IN INCHES.

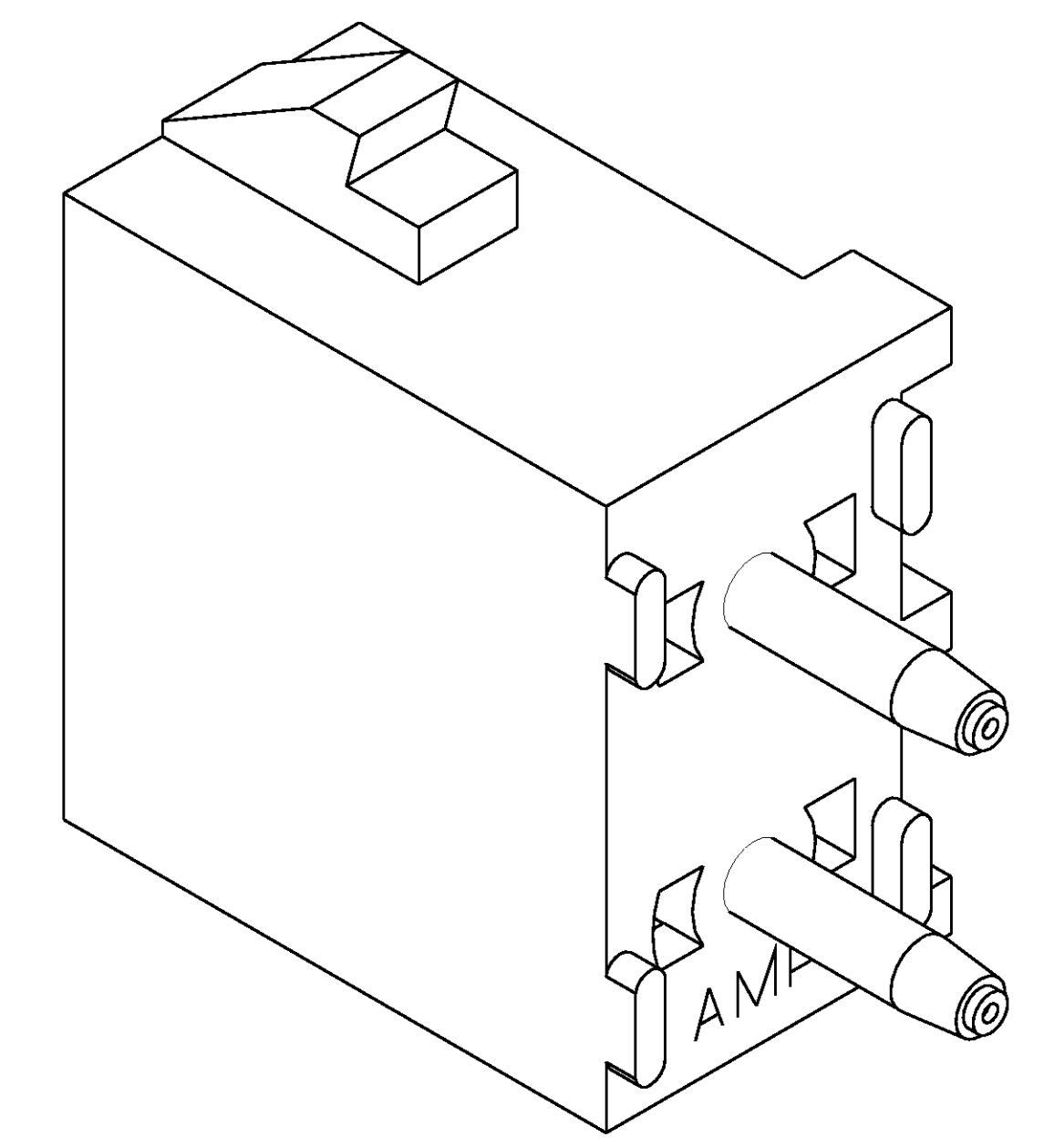

3-DIMENSIONAL MODEL  
NTS

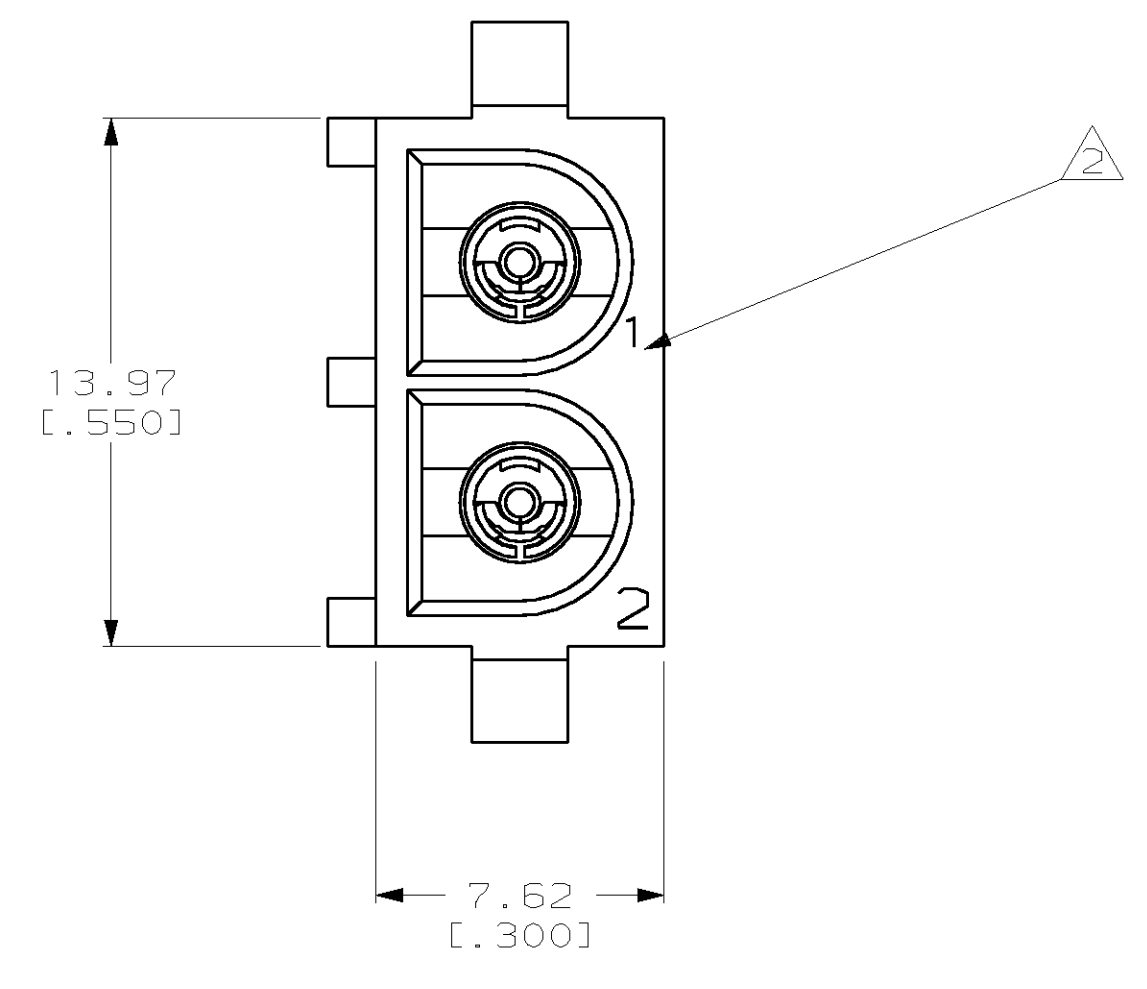
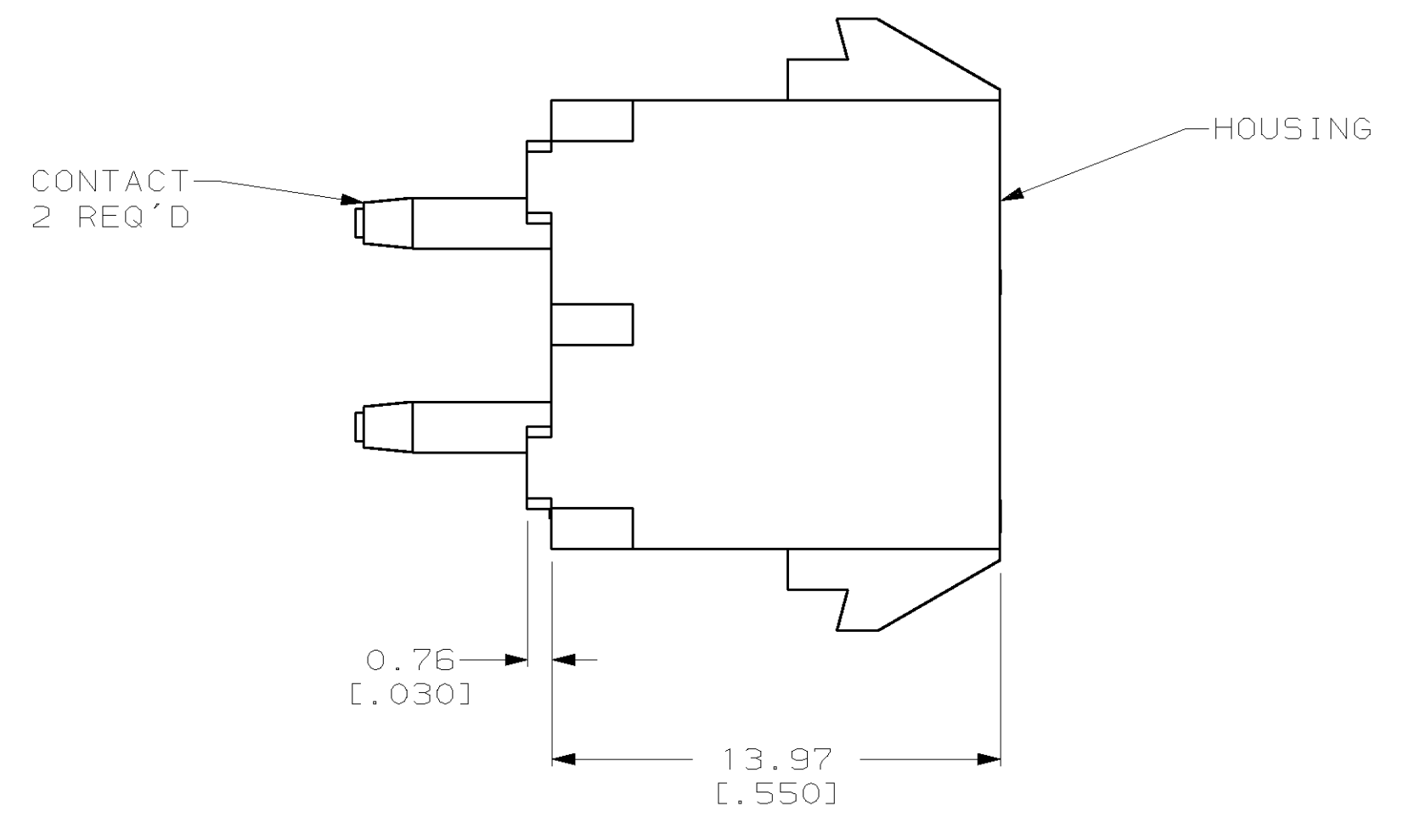
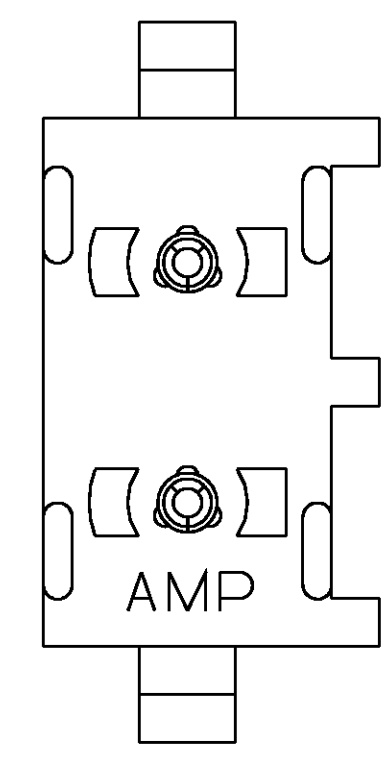
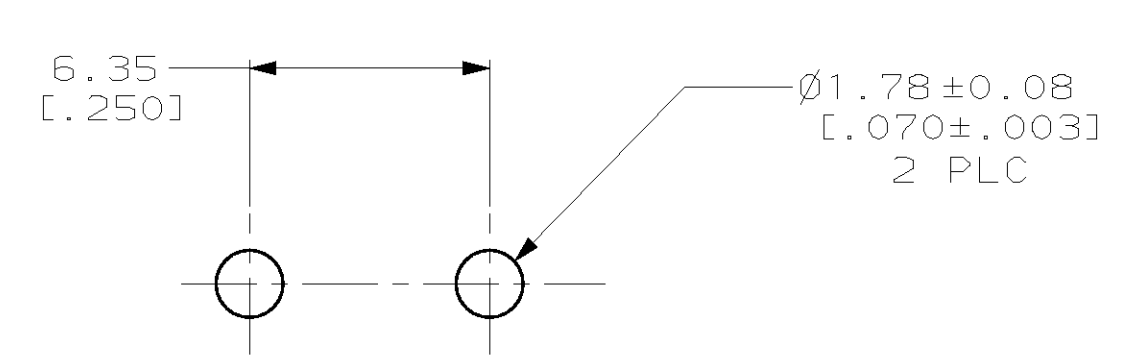
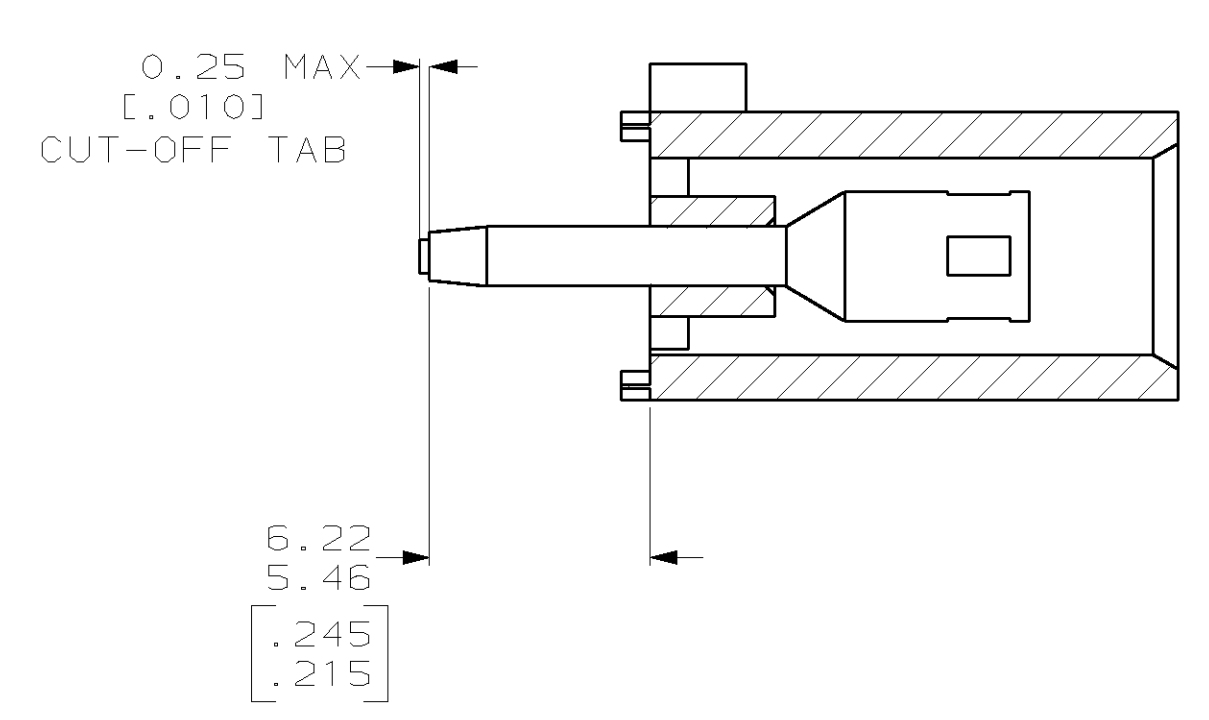

RECOMMENDED MOUNTING HOLE PATTERN  
FOR 3.18 [.125] THICK P.C. BOARD

PHOSPHOR BRONZE, PRE-TIN PIN CONTACT MATERIAL AND FINISH	NYLON, UL94V-2, NATURAL HOUSING MATERIAL	350986-4 PART NO
THIS DRAWING IS A CONTROLLED DOCUMENT. DIMENSIONS: mm (INCHES) TOLERANCES UNLESS OTHERWISE SPECIFIED: 0 PLC ± 1 PLC ± 2 PLC ±0.13 (.005) 3 PLC ± 4 PLC ± ANGLES: 40°/30° MATERIAL: SEE TABLE FINISH: SEE TABLE		DWN: B. LEWIS 8-19-98 CHK: R. SWING 8-19-98 APVD: M. TRULLI 8-19-98 PRODUCT SPEC: -- APPLICATION SPEC: -- WEIGHT: -- CUSTOMER DRAWING
AMP Incorporated Harrisburg, PA 17105-3608 SOCKET HEADER ASSEMBLY, 2 CIRCUIT UNIVERSAL MATE-N-LOK™		SIZE: A1 CAGE CODE: 00779 DRAWING NO: C-350986 SCALE: 5:1 SHEET: 1 OF 1 REV: J

