

Figure 1

### 1. INTRODUCTION

This instruction sheet covers the operation and maintenance of AMP\* Feed Track Assembly 853547-1 and Base Assembly 853542-1, designed to terminate, unstripped wire (18-22 AWG) in AMP MTA-.156 Closed-End Receptacle Connectors. The feed track assembly is used in AMP Electric Power Unit 931800-1 (409-5746) or AMP Bench Mount Power Assembly 58338-1 (408-9393). Refer to the instructions packaged with the power assemblies for feed track assembly installation and removal.

Read these instructions carefully before terminating any connectors.

#### NOTE

*All dimensions are in millimeters [with inches in brackets].*

Reasons for reissue are in Section 8, REVISION SUMMARY.

### 2. DESCRIPTION (Figure 1)

The feed track assembly terminates unstripped wire in four types of MTA-.156 Closed-End Receptacle Connectors: connectors with locking ramp *without* polarizing tabs; connectors with locking ramp *with* polarizing tabs; connectors without locking ramp *without* polarizing tabs; and connectors without locking ramp *with* polarizing tabs. The connectors contain slotted contacts on 3.96-mm [.156-in.] centers. See Figure 2.

The wires are terminated in the connector using the Insulation Displacement Contact (IDC) terminating technique, which is a method of inserting unstripped wire into a slotted contact beam to form a reliable electrical connection between the conductor and the contact.

**MTA-.156 Receptacle Connectors  
(Closed-End Style Only)**

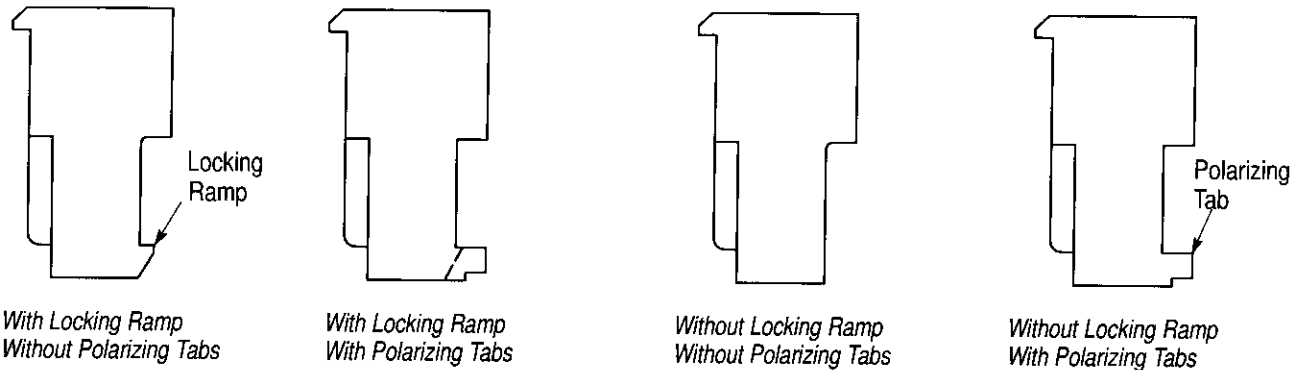

WIRE SIZE (AWG)	COLOR CODE	CLOSED-END STYLE WITH LOCKING RAMP		CLOSED-END STYLE WITHOUT LOCKING RAMP	
		WITHOUT POLARIZING TABS	WITH POLARIZING TABS	WITHOUT POLARIZING TABS	WITH POLARIZING TABS
18	Orange	640472	644878	640477	—
20	Yellow	640473	—	640478	—
22	Red	640474	644783	640479	644791
24	White	640475	—	640480	—
26	Blue	640476	—	640481	—

MTA-.156 Feed Track Assembly 853547-1 will also run the loose-piece connectors listed in the instruction sheet (408-9466) for MTA-.156 Feed Track Assembly 933568-1.

Figure 2

After the feed track assembly is installed into the power unit, it serves as a guide and support for the connector during termination. Features of the feed track assembly (see Figure 1) and their functions are as follows:

**Wire Inserter** — forces wire into the two slotted beams of the contact. Note that it provides support for the contact beams when applying insertion force on the wire.

**Adjuster (Insertion Rod)** — acts as a piston for — and regulates travel of — wire inserter.

**Feed Slide** — automatically advances the connector after each termination.

**Locating Pawl** — aligns connector for insertion and prevents the connector from moving out of position during the termination.

**Pawl Slide** — maintains a force against the connector to permit feeding.

**Feed Track** — serves as a storage area for connectors.

**3. SETUP INSTRUCTIONS**

**3.1. Base Assembly**

1. Assemble the reel support bracket to Base Plate 853543-1 using two 1/4-20 x .50L socket head cap screws (provided).
2. Assemble the guide plate to the reel support bracket using two 10-32 x .38L socket head cap screws (provided).
3. Mount the base assembly to a workbench using .25 in. dia fasteners (not provided).

**3.2. Feed Track Assembly**

1. Loosen the knurled knobs on the feed track assembly.
2. Slide the feed track assembly into position on the base assembly. The threaded portions of the knurled knobs fit into slots on the base assembly.
3. Tighten knurled knobs.
4. Pull out clip on power unit and slide power unit onto the Head 933808-1 of the feed track assembly.
5. Push in clip to secure the power unit to the track assembly.

6. Tighten screw on the power unit to secure the head.

9. Pull the pawl slide to the right until it reaches the spring pin which acts as a stop.

**3.3. Product Loading**

1. Remove the flange from the base assembly.
2. Slide the reel onto the reel support shaft. The mating face of connector must face operator. The holes in the reel should engage the adjustable reel brake.
3. Unreel some product around the stock guide and into the infeed guide on the track assembly.
4. Continue to feed product into the track.
5. Note that there is a slot located in the rear of the track by the track cover. Separate the tape from the product and place the tape in the slot.
6. Place the tape around the pulley one-half turn and feed tape through the hole on the front of the base plate of the base assembly.

**NOTE** *The sticky side of the tape must face **away** from the pulley.*

7. Pull on the tape to feed product down the track and into the insertion area.
8. Center the first position of the connector to be terminated in the wire insertion area.

**3.4. Connector Termination Test**

1. Determine the wire size and select the appropriate connector. (Connectors are color-coded according to the wire sizes they accommodate.)
2. Use a small knife to cut off wire retainers (strain relief). This will provide a clear view for inspecting the connector for a properly terminated wire in the contact. See Figure 3.
3. Place connector in feed track assembly and make a test termination using procedure described in Section 4, **TERMINATING PROCEDURE**, Steps 1 through 4.
4. Push connector out of left side of head.
5. Inspect the termination according to Section 5, **TERMINATION INSPECTION**, to ensure that the conductor is terminated past the lead-in transition and is positioned about half-way into the contact slot. The insulation should be 2.03 to 2.54 mm [.080 to .100 in.] beyond the front contact beam. See Figure 3.

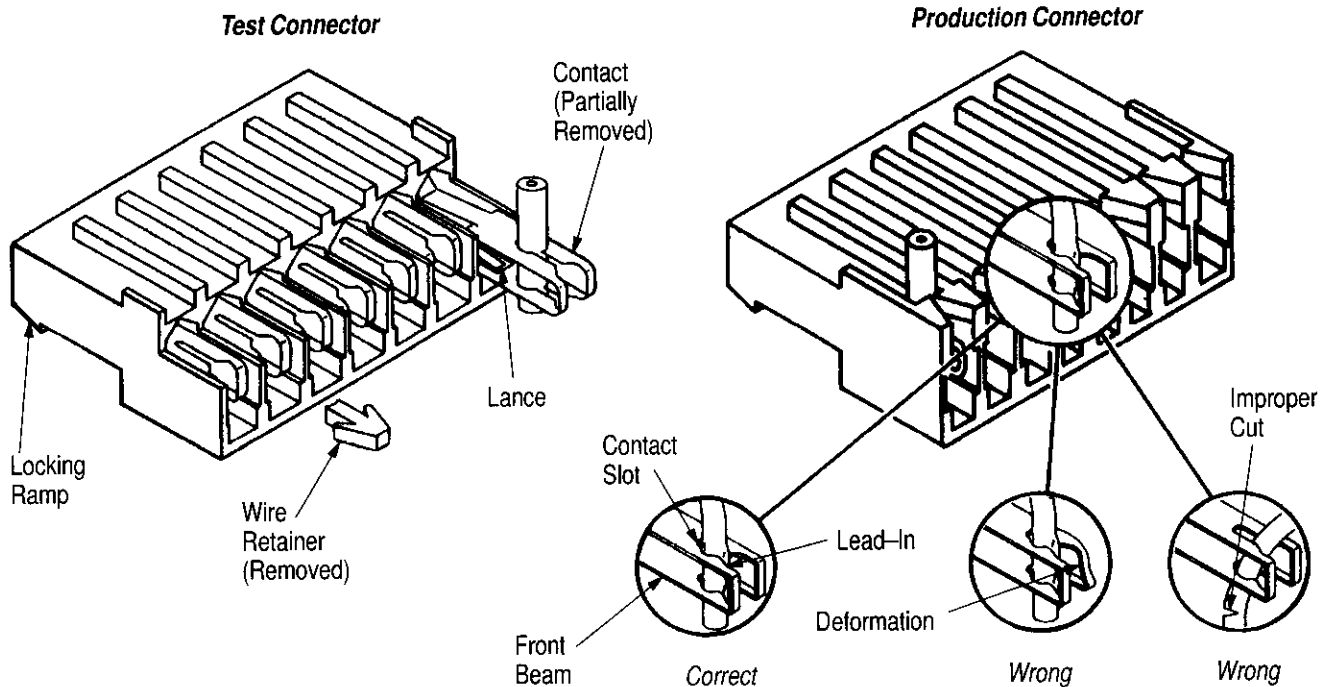

Figure 3

**NOTE**

For the bench mount power assembly only — if, after inspection, it is determined that the wire is not inserted deeply enough, increase the air pressure by 69 kPa [10 psi]. Repeat the termination and inspection procedure until either the proper insertion depth is obtained, or the air pressure is set to 483 kPa [70 psi]. If proper insertion depth is not achieved at 483 kPa [70 psi], return the air pressure to 276 kPa [40 psi] and follow the adjustment in Paragraph 3.2, Wire Insertion Depth Adjustment.

**3.5. Wire Insertion Depth Adjustment**

The adjuster (insertion rod) of the wire inserter is preset for the particular wire size used. If the wire is being inserted too deeply or not inserted deeply enough inside the contact, it may be necessary to adjust the depth of the wire inserter.

**CAUTION**

Care must be taken when making adjustments to the adjuster to avoid overstressing the head or power unit. Carefully insert the wire into the contact slot and adjust until the proper insertion depth is obtained.

**A. Wire Too Deep in Contact Slot**

If the wire is inserted too deeply, remove the head and turn the adjuster 1/6 turn **CLOCKWISE** (see Figure 4). This will reduce the wire insertion depth by approximately 0.20 mm [.008 in.].

**B. Wire Not Deep Enough in Contact Slot**

If the wire is not inserted deeply enough in the contact slot, remove the head and turn the adjuster 1/6 turn **COUNTERCLOCKWISE** (see Figure 4). This will increase the wire insertion depth by approximately 0.20 mm [.008 in.].

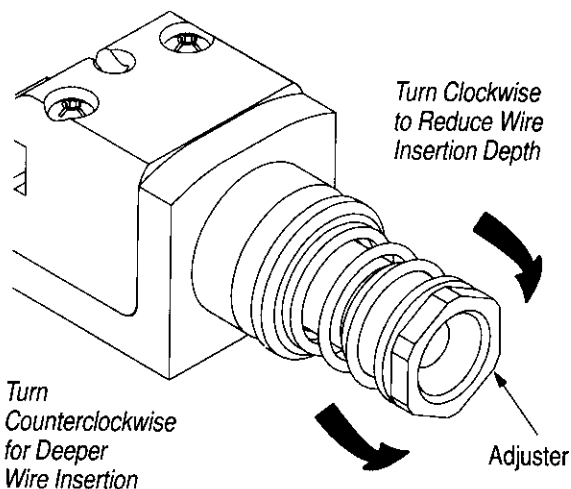

**NOTE:** 1/6 turn equals 0.20 mm [.008 in.] adjustment.

Figure 4

**3.6. Feed Adjustment**

A socket head adjustment screw, located on the left side of the housing insert, controls the location of the feed slide. If the screw is positioned **in** too far, the pawl on the feed slide will not engage in the connector housing and the housing will not advance. If the screw is **out** too far, the feed slide will back up until the pawl engages, and thus will incorrectly position the contact to be terminated. Adjust the feed slide by turning the adjustment screw either in or out until it aligns the contact with the inserter and engages the locator pawl in the connector housing. The following three observations are made when the feed slide is adjusted correctly:

1. The inserter is aligned with the contact to be terminated.
2. The locator pawl is engaged in the housing.
3. No movement of the housing occurs as the power unit is actuated.

**4. TERMINATING PROCEDURE** (Figure 5)

1. Load the feed track with connectors as described in Section 3.3, Product Loading.
2. Insert an unstripped wire into the funnel area between the contact and wire inserter until it bottoms in the head.
3. Depress the foot switch to crimp the wire to the contact. The wire inserter will retract and the feed slide will automatically advance the connector to the next contact position.

**NOTE**

The locating pawl will move up and down as the connector is automatically advanced through the head. However, if movement is obstructed, or if desired, the locating pawl can be depressed and the connector moved manually out the **LEFT** side of the head.

4. Repeat Steps 2 and 3 until all contacts have been terminated.
5. Inspect each termination according to the procedure in Section 5, **TERMINATION INSPECTION**.
6. Repeat Steps 2, 3, 4, and 5 until approximately 63.5 mm [2.5 in.] of connectors remain in the feed track.
7. Pull on the tape to reload the track with product.

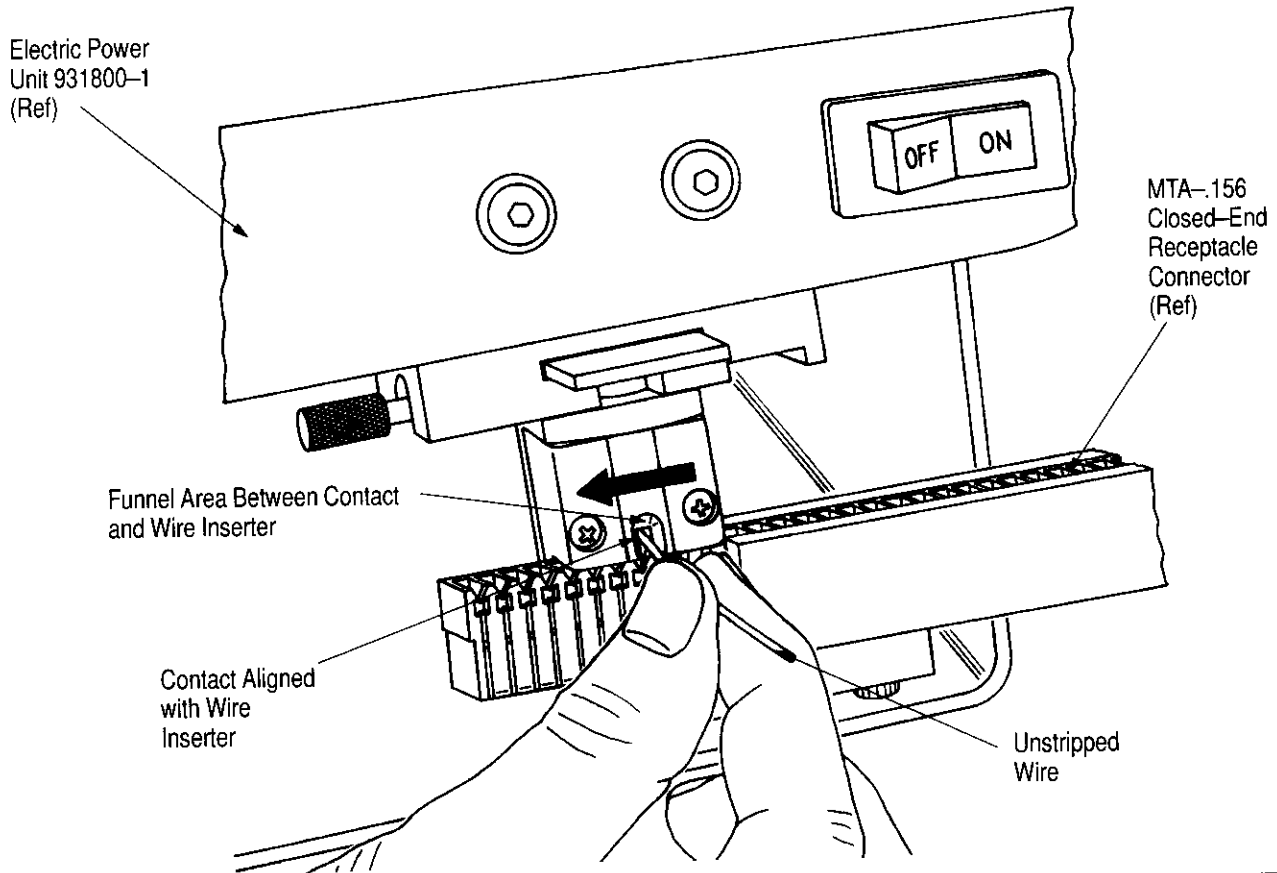

Figure 5

90-241

**NOTE**

When loading the track with product, leave approximately 6.4 mm [.25 in.] gap between product already in the feed track and new product being fed. Having no gap may result in connectors not being properly located in the termination area.

8. Pull the slide pawl to the right until it reaches the spring pin which acts as a stop

**CAUTION**

Hold onto the slide pawl as it is being moved along the feed track. A sudden release of the slide pawl will move connectors beyond the termination area.

**5. TERMINATION INSPECTION** (Figure 3)

AMP Application Specification 114-01020 lists the information necessary for termination inspection. Figure 3 represents properly and improperly terminated contacts which should be inspected as follows:

1. Make sure the conductor is terminated past the lead-in transition and about halfway in the contact slot.

2. The insulation should be 2.03 to 2.54 mm [.080 to .100 in.] beyond the front contact beam.

3. The wire is NOT bottomed in the contact slot.

4. The contact beams are NOT deformed. If damage is apparent, replace the contacts according to the instructions packaged with the connector.

5. The insulation is NOT nicked or cut in any area other than the two wire slots.

6. The wire extends below the strain relief features of the connector.

**6. INSPECTION**

AMP recommends that the feed track assembly be inspected immediately upon its arrival at your facility to ensure that it has not been damaged during transit. Customer-replaceable parts are listed in Figures 6 and 7. When parts are needed, order by part number and description from:

CUSTOMER SERVICE (38-35)  
AMP INCORPORATED  
P.O. BOX 3608  
HARRISBURG, PA 17105-3608

### 6.1. Daily Maintenance

It is recommended that each operator be made aware of — and responsible for — the following steps of daily maintenance:

1. Remove dust, moisture, and other contaminants with a clean brush or a soft, lint-free cloth. Do NOT use objects that could damage the feed track assembly.
2. Make sure all components are in place and properly secured.

### 6.2. Periodic Inspection

Regular inspections should be performed by quality control personnel. A record of scheduled inspections should remain with the track assembly and/or be supplied to supervisory personnel. Though recommendations call for at least one inspection a month, the inspection frequency should be based on the amount of use, working conditions, operator training and skill, and established company standards. These inspections should include a visual inspection and should be performed in the sequence shown in Section 6.3, Visual Inspection.

### 6.3. Visual Inspection

1. Remove dust, moisture, and other contaminants with a clean brush or a soft, lint-free cloth. Do NOT use objects that could damage the feed track assembly.
2. Make sure all components are in place and properly secured.
3. Check for chipped, cracked, worn, or broken areas. If damage is evident, repair is necessary. See Section 7, REPLACEMENT AND REPAIR.

## 7. REPLACEMENT AND REPAIR

AMP recommends that certain replaceable parts be stocked by the customer to prevent loss of production time. The parts listed in Figure 6 can be replaced by qualified personnel at your production or tool repair facility.

**NOTE**

*When replacing components in the MTA Head Assembly, the customer can: 1) order the head with a single part number and receive a complete, tested MTA head that is ready for installation into the feed track; or 2) purchase individual components that make up the head assembly. AMP recommends stocking a single head assembly.*

If it is necessary to return the tooling for repair, send the tooling with a written description of the problem to:

CUSTOMER REPAIR (01-12)  
AMP INCORPORATED  
1523 NORTH 4TH STREET  
HARRISBURG, PA 17102-1604

## 8. REVISION SUMMARY

Since the previous release of this sheet, the following changes were made per EC 0990-0200-96:

- Added reference about Bench Mount Power Assembly 58338-1 (408-9393)
- Added connector styles and part numbers to Figure 2
- Added MTA-.156 Head Assembly 318863-1
- Updated format
- Added metric units

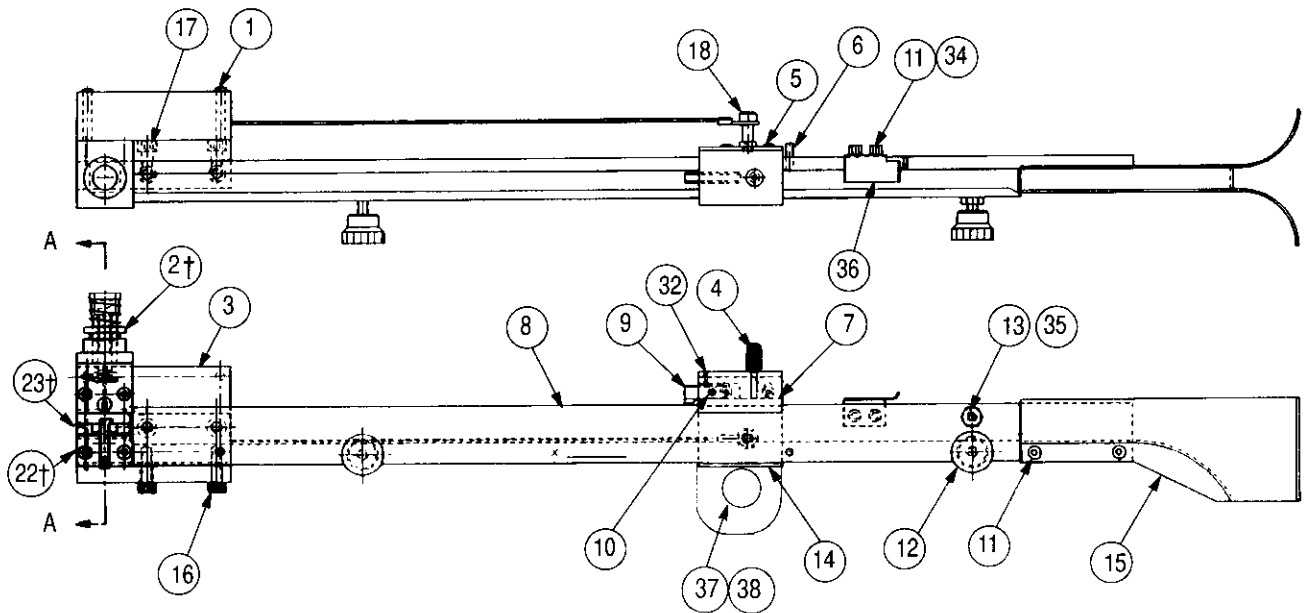

Section A-A

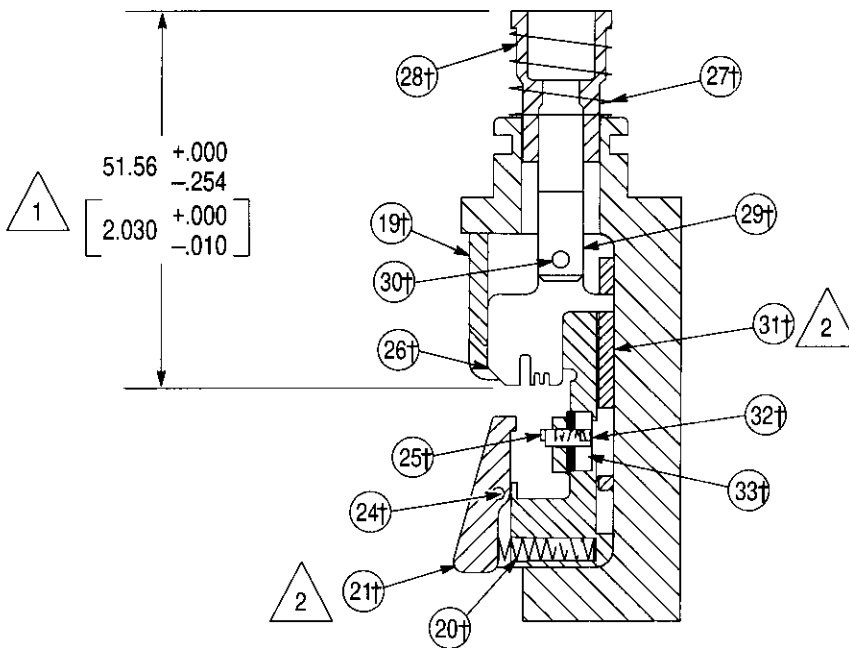

- △ 1 Adjust Item 28† for initial setting. Reference Paragraph 3.5 for final adjustment procedure.
- △ 2 Lubricate with EP Lithium grease during component replacement.
- △ 3 "†" indicates those parts included in MTA-.156 Head Assembly 318863-1. Insertion Head Assembly 318863-1 can be ordered, stocked, and replaced as a single, tested unit.

MTA .156 Head Assembly 318863-1

**Weight:** 1641 g [3 lb. 10 oz.]

Figure 6 (cont'd)

## REPLACEMENT PARTS 853547-1

ITEM	PART NUMBER	DESCRIPTION	QTY PER ASSY
1	4-22430-9	SCREW, Machine 4-40 UNC x 1.00	2
2†	933808-1	HEAD	1
3	983533-1	PULLBOX	1
4	2-22346-4	SCREW, Thumb, Knurled	1
5	1-21002-4	SCREW, Btn Hd Cap, (No. 4-40 UNC x .38)	2
6	5-21028-1	PIN, Slotted Spring	1
7	853548-1	SLIDE, Pawl	1
8	853550-1	TRACK	1
9	853551-1	PAWL	1
10	5-21028-9	PIN, Slotted Spring	1
11	1-21000-8	SCREW, Skt Hd Cap, (No. 6-32 UNC x .25)	4
12	981262-1	KNOB, Knurled	2
13	2-23057-3	PLUNGER, Ball	1
14	853552-1	GUIDE, Slide	1
15	853553-1	GUIDE, Infeed	1
16	3-21000-5	SCREW, Skt Hd Cap, (No. 10-32 UNF x .50)	2
17	3-21000-4	SCREW, Skt Hd Cap, (No. 10-32 UNF x .38)	2
18	27210-5	SCREW, Shoulder	1
19†	313814-1	HOUSING, Insert	1
20†	22278-9	SPRING, Compression	1
21†	768531-2	PAWL, Locating	1
22†	4-22430-8	SCREW, Machine (No. 4-40 UNC x .88)	4
23†	1-21010-9	SCREW, Skt Set (No. 4-40 UNC x .125)	1
24†	21041-7	PIN, Spiral Spring	1
25†	312192-1	PAWL, Finished Feed	1
26†	312154-1	INSERTER, Wire	1
27†	1-22488-5	SPRING, Compression	1
28†	312149-1	ADJUSTER, Rod Inserter	1
29†	312148-1	ROD, Inserter	1
30†	3-21028-2	PIN, Slotted Spring	1
31†	768530-2	CAM, Traverse Slide	1
32†	1-23147-2	SPRING, Compression	1
33†	312151-1	SLIDE, Feed	2
34	21024-3	WASHER, Lock No. 6	1
35	21018-6	NUT, (No. 8-32 UNC)	1
36	853554-1	COVER, Track	1
37	22925-2	FOLLOWER, Cam	1
38	21018-7	NUT, Hex, 10-32	1

† Parts included in MTA -.156 Insertion Head 318863-1. Insertion Head 318863-1 may be ordered, stocked and replaced as a complete, assembled unit.

Figure 6 (end)



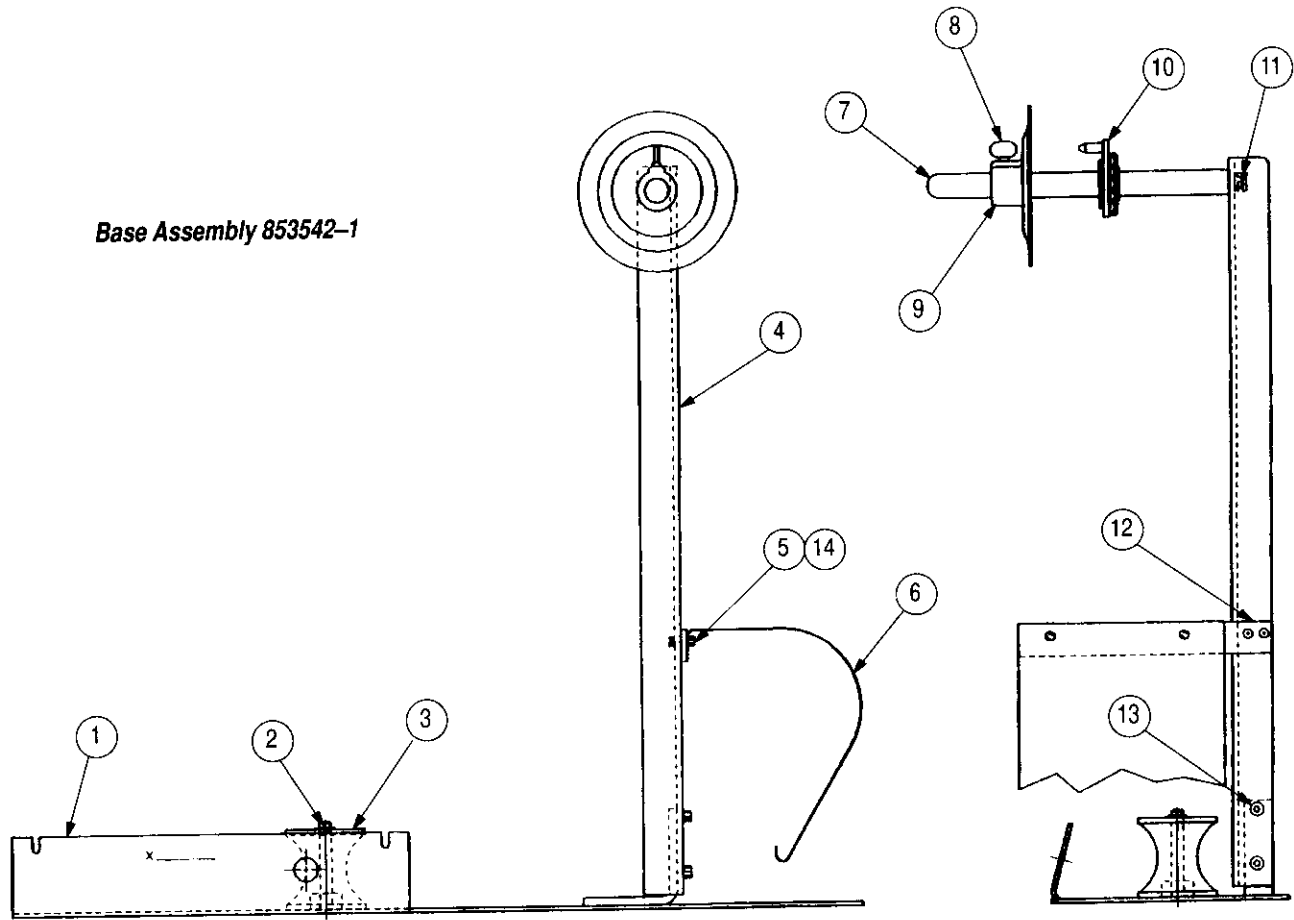

Base Assembly 853542-1

**REPLACEMENT PARTS**

ITEM	PART NUMBER	DESCRIPTION	QTY PER ASSY
1	853543-1	PLATE, Base	1
2	28859-2	NUT, Push-On	1
3	853544-1	PULLEY	1
4	455584-1	BRACKET, Reel Support	1
5	3-21000-4	SCREW, Skt Hd Cap, (No. 10-32 x .38)	4
6	470268-1	STOCK, Guide	1
7	465586-2	SHAFT, Reel Support	1
8	2-22789-6	SCREW, Thumb, (No. 1/4-20 UNC x .50)	1
9	465520-1	FLANGE	1
10	689693-2	ADJUSTABLE REEL BRAKE	1
11	3-21001-5	SCREW, Skt Hd Cap, (No. 3/8-16 UNC x 1.00)	1
12	853545-1	PLATE, Guide	1
13	21001-2	SCREW, Skt Hd Cap, (No. 1/4-20 UNC x .50)	2
14	21055-7	WASHER, Flat	2

Figure 7